

Pumps—Shaft Sealing Systems for Centrifugal and Rotary Pumps

API STANDARD 682
FOURTH EDITION, MAY 2014



AMERICAN PETROLEUM INSTITUTE

Special Notes

API publications necessarily address problems of a general nature. With respect to particular circumstances, local, state, and federal laws and regulations should be reviewed.

Neither API nor any of API's employees, subcontractors, consultants, committees, or other assignees make any warranty or representation, either express or implied, with respect to the accuracy, completeness, or usefulness of the information contained herein, or assume any liability or responsibility for any use, or the results of such use, of any information or process disclosed in this publication. Neither API nor any of API's employees, subcontractors, consultants, or other assignees represent that use of this publication would not infringe upon privately owned rights.

API publications may be used by anyone desiring to do so. Every effort has been made by the Institute to assure the accuracy and reliability of the data contained in them; however, the Institute makes no representation, warranty, or guarantee in connection with this publication and hereby expressly disclaims any liability or responsibility for loss or damage resulting from its use or for the violation of any authorities having jurisdiction with which this publication may conflict.

API publications are published to facilitate the broad availability of proven, sound engineering and operating practices. These publications are not intended to obviate the need for applying sound engineering judgment regarding when and where these publications should be utilized. The formulation and publication of API publications is not intended in any way to inhibit anyone from using any other practices.

Any manufacturer marking equipment or materials in conformance with the marking requirements of an API standard is solely responsible for complying with all the applicable requirements of that standard. API does not represent, warrant, or guarantee that such products do in fact conform to the applicable API standard.

Users of this Standard should not rely exclusively on the information contained in this document. Sound business, scientific, engineering, and safety judgment should be used in employing the information contained herein.

All rights reserved. No part of this work may be reproduced, translated, stored in a retrieval system, or transmitted by any means, electronic, mechanical, photocopying, recording, or otherwise, without prior written permission from the publisher. Contact the Publisher, API Publishing Services, 1220 L Street, NW, Washington, DC 20005.

Copyright © 2014 American Petroleum Institute

Foreword

Nothing contained in any API publication is to be construed as granting any right, by implication or otherwise, for the manufacture, sale, or use of any method, apparatus, or product covered by letters patent. Neither should anything contained in the publication be construed as insuring anyone against liability for infringement of letters patent.

Shall: As used in a standard, “shall” denotes a minimum requirement in order to conform to the specification.

Should: As used in a standard, “should” denotes a recommendation or that which is advised but not required in order to conform to the specification.

This document was produced under API standardization procedures that ensure appropriate notification and participation in the developmental process and is designated as an API standard. Questions concerning the interpretation of the content of this publication or comments and questions concerning the procedures under which this publication was developed should be directed in writing to the Director of Standards, American Petroleum Institute, 1220 L Street, NW, Washington, DC 20005. Requests for permission to reproduce or translate all or any part of the material published herein should also be addressed to the director.

Generally, API standards are reviewed and revised, reaffirmed, or withdrawn at least every five years. A one-time extension of up to two years may be added to this review cycle. Status of the publication can be ascertained from the API Standards Department, telephone (202) 682-8000. A catalog of API publications and materials is published annually by API, 1220 L Street, NW, Washington, DC 20005.

Suggested revisions are invited and should be submitted to the Standards Department, API, 1220 L Street, NW, Washington, DC 20005, standards@api.org.

Contents

Page

1	Scope	1
2	Normative References	1
3	Terms, Definitions, and Symbols	3
3.1	Terms and Definitions	3
3.2	Symbols	12
4	Sealing Systems	13
4.1	Seal Categories, Types, and Arrangements	13
4.2	Objectives	15
4.3	Specifying and/or Purchasing a Sealing System	15
5	General	23
5.1	Unit Responsibility	23
5.2	Dimensions	23
6	Design Requirements	23
6.1	Common Design Requirements (All Categories)	23
6.2	Design Requirements (Category-specific)	45
7	Specific Seal Configurations	48
7.1	Arrangement 1 Seals	48
7.2	Arrangement 2 Seals	49
7.3	Arrangement 3 Seals	52
8	Accessories	54
8.1	General	54
8.2	Piping for Seal Auxiliary Systems	56
8.3	Components of Seal Auxiliary Systems (if Specified in Annex G)	59
9	Instrumentation	72
9.1	General	72
9.2	Temperature-indicating Gauges	72
9.3	Thermowells	73
9.4	Pressure Indicators	73
9.5	Transmitters and Switches	73
9.6	Level Indicators	74
9.7	Flow Instruments	74
9.8	Relief Valves	74
9.9	Pressure Control Valves	75
9.10	Pressure Amplifiers	75
10	Inspection, Testing, and Preparation for Shipment	75
10.1	General	75
10.2	Inspection	75
10.3	Testing	76
10.4	Preparation for Shipment	80
11	Data Transfer	81
11.1	General	81
11.2	Data Requirement Forms	82
11.3	Datasheet	82
11.4	Inspector Checklist	82

Contents

	Page
Annex A (informative) Recommended Seal Selection Procedure	83
Annex B (informative) Typical Materials and Material Specifications for Seal Chamber and Mechanical Seal Components	111
Annex C (informative) Mechanical Seals Datasheets	127
Annex D (informative) Seal Codes	132
Annex E (normative) Mechanical Seals Data Requirement Forms	137
Annex F (informative) Technical Tutorials and Illustrative Calculations	140
Annex G (normative) Standard Piping Plans and Auxiliary Hardware	183
Annex H (informative) Inspectors' Checklist for All Seals	230
Annex I (normative) Seal Qualification Testing Protocol	231
Bibliography	254
Figures	
1 Seal Configurations	16
2 Arrangement 1: One Seal per Cartridge Assembly	17
3 Arrangement 2: Two Seals per Cartridge Assembly with a Liquid Buffer Fluid	18
4 Arrangement 2: Two Seals per Cartridge Assembly with or Without a Gas Buffer Fluid	19
5 Arrangement 3: Two Seals per Cartridge Assembly with a Liquid Barrier Fluid	20
6 Arrangement 3: Two Seals per Cartridge Assembly with a Gas Barrier Fluid	21
7 Arrangement 1 Type A Seals	22
8 Arrangement 1 Type B Seals	22
9 Arrangement 1 Type C Seals	22
10 Retention of Seal Components in Vacuum Services and Arrangement 3 Inner Seal	25
11 Seal Chamber Types	26
12 Seal Chamber Register Concentricity	29
13 Section Showing Seal Gland Plate Shoulder	29
14 Seal Chamber Face Runout	30
15 Mechanical Seal Piping Connections	34
16 Plastic Plug with Center Tab and Example of Warning Tag	34
17 Seal Chamber/Gland Plate for Vertical Pumps	34
18 Mating Joint Gasket	35
19 Seal Sleeve Runout	36
20 Auxiliary Sleeve Arrangement	38
21 Seal Sleeve Attachment by Shrink Disk	39
22 Seal Sleeve Attachment by Split Ring	40
23 Clamped Faces	40
24 Distributed Flush Systems	47
25 Attachment of Key Drives to Shaft	47
26 Section Showing Containment-Seal Chamber Bushing for 2CW-CS and 2NC-CS Configurations	51
27 Seal Testing Sequence	77
A.1 Seal Selection Logic	107
A.2 Group II Seal Arrangement Selection Chart	108

Contents

	Page
A.3 Conversion of mg/m ³ to ppmv at 25 °C (77 °F) and Atmospheric Pressure	109
A.4 Temperature Correction Factor for Figure A.3.	110
B.1 Relative PV Comparisons for Seal Face Combinations	121
F.1 Estimated Gas Leakage for 50 mm Shaft at 0.7 bar, Expressed in Normal Liters per Minute	142
F.2 Estimated Liquid (Water) Leakage for 50 mm Shaft at 2.75 bar, Expressed in Cubic Centimeters per Minute.	143
F.3 Illustration of Alternative Vapor Pressure Margin Calculation Options	145
F.4 Illustration of Vapor Pressure Margin Calculation Methods as Applied to Propane	145
F.5 Illustration of Balance Ratio Measurement Points	149
F.6 Gland Plate Model	156
F.7 System Model.	156
F.8 Pipe System Friction Curves	157
F.9 Tubing System Friction Curves	158
F.10 Circulating Device Performance and System Resistance in Tubing System Curves	160
F.11 Circulating Device Performance and System Resistance in Pipe System Curves	160
F.12 Typical Required Flush Flow for Arrangement 3 CW Seals Without Heat Soak Considered and a Pumped Fluid Temperature of 54 °C (130 °F)	161
F.13 Typical Required Flush Flow for Arrangement 3 CW Seals with Heat Soak Considered and a Pumped Fluid Temperature of 176 °C (350 °F)	161
F.14 Typical Required Flush Flow for Arrangement 3 CW Seals with Heat Soak Considered and a Pumped Fluid Temperature of 260 °C (500 °F)	162
F.15 Typical Required Flush Flow for Arrangement 3CW Seals with Heat Soak Considered and a Pumped Fluid Temperature of 371 °C (700 °F)	162
F.16 Calculation Points for Piping Plan 53A Systems.	165
F.17 Pressure Alarm Without Temperature Bias	169
F.18 Barrier Liquid Pressure versus Accumulator Gas Volume	170
F.19 Barrier Liquid Pressure Against Barrier Liquid Volume	171
F.20 Drive Collar Holding Capability	178
G.1 Instrument Symbols	184
G.2 Equipment Symbols	185
G.3 Standard Seal Piping Plan 01	186
G.4 Standard Seal Piping Plan 02	187
G.5 Standard Seal Piping Plan 03	188
G.6 Standard Seal Piping Plan 11	189
G.7 Standard Seal Piping Plan 12	190
G.8 Standard Seal Piping Plan 13	191
G.9 Standard Seal Piping Plan 14	192
G.10 Standard Seal Piping Plan 21	193
G.11 Standard Seal Piping Plan 22	194
G.12 Standard Seal Piping Plan 23	195
G.13 Standard Seal Piping Plan 31	197
G.14 Standard Seal Piping Plan 32	198
G.15 Standard Seal Piping Plan 41	199
G.16 Standard Seal Piping Plan 51	200
G.17 Standard Seal Piping Plan 52	201

Contents

	Page
G.18 Standard Seal Piping Plan 53A	203
G.19 Standard Seal Piping Plan 53B	205
G.20 Standard Seal Piping Plan 53C	207
G.21 Standard Seal Piping Plan 54	209
G.22 Standard Seal Piping Plan 55	210
G.23 Standard Seal Piping Plan 61	211
G.24 Standard Seal Piping Plan 62	212
G.25 Standard Seal Piping Plan 65A	213
G.26 Standard Seal Piping Plan 65B	214
G.27 Standard Seal Piping Plan 66A	215
G.28 Standard Seal Piping Plan 66B	216
G.29 Standard Seal Piping Plan 71	217
G.30 Standard Seal Piping Plan 72	218
G.31 Standard Seal Piping Plan 74	219
G.32 Standard Seal Piping Plan 75	221
G.33 Standard Seal Piping Plan 76	223
G.35 Standard External Barrier/Buffer Fluid Reservoir	225
G.36 Alternative External Barrier/Buffer Fluid Reservoir	226
G.37 Typical Installation of a Piping Plan 23 Circulation System	227
G.38 Typical Installation of a Barrier/Buffer Fluid Reservoir	228
H.1 Inspectors' Checklist	230
I.1 Water Test Parameters	244
I.2 Propane Test Parameters	245
I.3 Caustic (NaOH) Test Parameters	246
I.4 Mineral Oil Test Parameters for Applications Between 5 °C and 176 °C (23 °F and 348.8 °F)	247
I.5 Mineral Oil Test Parameters for Applications Between 176 °C and 400 °C (348.8 °F and 750 °F)	248
I.6 Seal Manufacturer Qualification Test Procedure	249
I.7 Seal Manufacturer Qualification Test Procedure for Containment Seals	250
I.8 Seal Manufacturer Qualification Test Procedure for Gas Barrier Seals	251
I.9 Mechanical Seal Qualification Test Form (1CW, 2CW-CW, 3CW-FB, 3CW-FF, and 3CW-BB)	252
I.10 Mechanical Seal Qualification Test Form (2CW-CS, 2NC-CS, 3NC-FF, 3NC-BB, and 3NC-FB)	253
 Tables	
1 Clearances Between Rotary and Stationary Components	28
2 Symbols and Size for Seal Chamber and Gland Plate Connections	33
3 Minimum Sleeve Thickness in the Area of Component-drive Set Screws	37
4 Minimum Requirements for Auxiliary Piping	57
5 Minimum Pipe Wall Thickness	58
6 Minimum Tubing Wall Thickness	58
7 Conditions Affecting Cooling Water System Design	61
8 Approximate Densities of Materials Found in Process Streams	63
9 Sizing of Bladder Accumulators	66
10 Nameplate for Bladder Accumulator	69
A.1 R-phrase Grouping Table	105
A.2 H Statement Grouping Table	106

Contents

	Page
B.1 Materials Standards	112
B.2 Miscellaneous Materials Specifications	117
B.3 Typical Temperature Limits for Seal Face Materials	118
B.4 Typical Temperature Limits for Secondary Seals	122
B.5 Typical Hardness Range for Selected Secondary Seals	125
D.1 Example of an Arrangement 1 Mechanical Seal Code	132
D.2 API 610 Mechanical Seal Code (Obsolete)	135
F.1 Pipe and Tube Dimensions for System Loss Calculations	157
F.2 Typical Hardness Ranges for Set Screw Materials	179
F.3 Typical Hardness Ranges for Pump Shaft Materials	179
F.4 Estimated Sleeve Axial Loads	179
I.1 Organization of Qualification Testing	233
I.2 Qualification Test Fluid and Pumped Fluid Selection Chart	237
I.3 Seal Qualification Test Parameters	241

Pumps—Shaft Sealing Systems for Centrifugal and Rotary Pumps

1 Scope

This standard specifies requirements and gives recommendations for sealing systems for centrifugal and rotary pumps used in the petroleum, natural gas, and chemical industries. See A.1.1 and A.1.2. It is the responsibility of the purchaser or seal vendor to ensure that the selected seal and auxiliaries are suitable for the intended service condition. It is applicable mainly for hazardous, flammable, and/or toxic services where a greater degree of reliability is required for the improvement of equipment availability and the reduction of both emissions to the atmosphere and life-cycle sealing costs. It covers seals for pump shaft diameters from 20 mm (0.75 in.) to 110 mm (4.3 in.).

This standard is also applicable to seal spare parts and can be referred to for the upgrading of existing equipment. A classification system for the seal configurations covered by this standard into categories, types, arrangements, and orientations is provided.

This standard is referenced normatively in API 610. It is applicable to both new and retrofitted pumps and to pumps other than API 610 pumps (e.g. ASME B73.1, ASME B73.2, and API 676 pumps).

This standard might also be referenced by other machinery standards such as other pumps, compressors, and agitators. Users are cautioned that this standard is not specifically written to address all of the potential applications that a purchaser may specify. This is especially true for the size envelope specified for API 682 seals. The purchaser and seal vendor shall mutually agree on the features taken from this standard and used in the application.

2 Normative References

The following referenced documents are indispensable for the application of this document. For dated references, only the edition cited applies. For undated references, the latest edition of the referenced document (including any amendments) applies.

API Recommended Practice 520 (all parts), *Sizing, Selection, and Installation of Pressure-relieving Devices in Refineries*

API Standard 526, *Flanged Steel Pressure Relief Valves*

API Standard 610, *Centrifugal Pumps for Petroleum, Petrochemical and Natural Gas Industries*

API Standard 614 *Lubrication, Shaft-sealing and Control-oil Systems and Auxiliaries for Petroleum, Chemical, and Gas Industry Services*

ASME V¹, *ASME Boiler and Pressure Vessel Code, Section V, Non-destructive Examination*

ASME VIII, *ASME Boiler and Pressure Vessel Code, Section VIII, Rules for the Construction of Pressure vessels*

ASME IX, *ASME Boiler and Pressure Vessel Code, Section IX, Welding and Brazing Qualifications*

ASME B1.1, *Unified Inch Screw Threads (UN and UNR Thread Form)*

ASME B1.20.1, *Pipe Threads, General Purpose, Inch*

ASME B16.11, *Forged Fittings, Socket-welding and Threaded*

ASME B16.20, *Metallic Gaskets for Pipe Flanges—Ring Joint, Spiral-wound, and Jacketed*

¹ ASME International, 3 Park Avenue, New York, New York 10016-5990, www.asme.org.

ASME B31.3, *Process Piping*

ASME B73.1, *Specification for Horizontal End Suction Centrifugal Pumps for Chemical Process*

ASME B73.2, *Specification for Vertical In-line Centrifugal Pumps for Chemical Process*

ASME PTC 8.2, *Centrifugal Pumps, Performance Test Codes*

AWS D1.1², *Structural Welding Code—Steel*

EN 287 (all parts)³, *Approval testing of welders—fusion welding*

EN 288 (all parts), *Specification and approval of welding procedures for metallic materials*

EN 13445 (all parts), *Unfired pressure vessels*

EPA Method 21⁴, Appendix A of Title 40, Part 60 of the U.S. Code of Federal Regulations, *Environmental Protection Agency, United States, Determination of Volatile Organic Compound Leaks*

IEC 60079 (all parts)⁵, *Electrical apparatus for explosive gas atmospheres*

IEC 60529, *Degrees of protection provided by enclosures (IP code)*

ISO 7 (all parts)⁶, *Pipe threads where pressure-tight joints are made on the threads*

ISO 261, *ISO general-purpose metric screw threads—General plan*

ISO 262, *ISO general-purpose metric screw threads—Selected sizes for screws, bolts, and nuts*

ISO 286-2, *ISO system of limits and fits—Part 2: Tables of standard tolerance grades and limit deviations for holes and shafts*

ISO 724, *ISO general-purpose metric screw threads—basic dimensions*

ISO 965 (all parts), *ISO general-purpose metric screw threads—Tolerances*

ISO 7005-1, *Metallic flanges—Part 1: Steel flanges*

ISO 15649, *Petroleum and natural gas industries—Piping*

NEMA 250⁷, *Enclosures for Electrical Equipment (1,000 Volts Maximum)*

NFPA 70⁸, *National Electrical Code*

Title 1, Part A, Section 112, *U.S. National Emission Standards for Hazardous Air Pollutants (NESHAPs) (Clean Air Act Amendment, Air Pollution Prevention and Control, Air Quality and Emissions Limitations, Hazardous Air Pollutants)*

² American Welding Society, 550 NW LeJeune Road, Miami, Florida 33126, www.aws.org.

³ European Committee for Standardization, Avenue Marnix 17, B-1000 Brussels, Belgium, www.cen.eu.

⁴ U.S. Environmental Protection Agency, Ariel Rios Building, 1200 Pennsylvania Avenue, Washington, DC 20460, www.epa.gov.

⁵ International Electrotechnical Commission, 3, rue de Varembé, P.O. Box 131, CH-1211 Geneva 20, Switzerland, www.iec.ch.

⁶ International Organization for Standardization, 1, ch. de la Voie-Creuse, Case postale 56, CH-1211 Geneva 20, Switzerland, www.iso.org.

⁷ National Electrical Manufacturers Association, 1300 North 17th Street, Suite 1752, Rosslyn, Virginia 22209, www.nema.org.

⁸ National Fire Protection Association, 1 Batterymarch Park, Quincy, Massachusetts 02169-7471, www.nfpa.org.

3 Terms, Definitions, and Symbols

For the purposes of this document, the following terms and definitions apply.

3.1 Terms and Definitions

3.1.1

antirotation device

Device used to prevent rotation of one component relative to an adjacent component in a seal assembly.

EXAMPLES Key, pin.

3.1.2

Arrangement 1 seal

See 4.1.4.

3.1.3

Arrangement 2 seal

See 4.1.4.

3.1.4

Arrangement 3 seal

See 4.1.4.

3.1.5

atmospheric leakage collector

External reservoir arranged to capture liquid seal leakage from an Arrangement 1 seal.

3.1.6

auxiliary sleeve

Separate sleeve mounted on the outer diameter of the seal shaft sleeve that facilitates assembly of seal components.

3.1.7

back-to-back configuration

Dual seal in which both of the flexible elements are mounted between the mating rings, the sealed fluid is on the ID of the inner seal, and the barrier or buffer fluid is on the OD of the inner and outer seal.

3.1.8

balanced seal

Mechanical seal in which the fluid closing forces have been modified through seal design.

NOTE In this standard the seal balance ratio is less than 1 (see balance ratio calculation in Annex F).

3.1.9

barrier fluid

Externally supplied fluid at a pressure above the pump seal chamber pressure, introduced into an Arrangement 3 seal to completely isolate the process liquid from the environment.

3.1.10

barrier/buffer seal chamber

Component or aggregate of components that form the cavity into which the outer seal of a pressurized or unpressurized dual seal is installed and in which a barrier or buffer fluid is circulated.

3.1.11**bellows seal**

Type of mechanical seal that uses a flexible metal bellows to provide secondary sealing and spring loading.

3.1.12**buffer fluid**

Externally supplied fluid, at a pressure lower than the pump seal chamber pressure, used as a lubricant and/or to provide a diluent in an Arrangement 2 seal.

3.1.13**cartridge seal**

Completely self-contained unit (including seal/rings, mating ring/s, flexible elements, secondary seal, seal gland plate, and sleeve) that is preassembled and preset before installation.

3.1.14**Category 1 seal**

See 4.1.2.

3.1.15**Category 2 seal**

See 4.1.2.

3.1.16**Category 3 seal**

See 4.1.2.

3.1.17**connection**

Threaded or flanged joint that mates a port to a pipe or to a piece of tubing.

3.1.18**contacting seal**

Seal design in which the mating faces are not designed to intentionally create aerodynamic or hydrodynamic forces to sustain a specific separation gap.

NOTE Contacting seals can actually develop a full fluid film, but this is not typical. Contacting seals do not incorporate geometry (e.g. grooves, pads, face waviness) to ensure that the faces do not touch. The amount of contact is generally very low and permits reliable operation with low leakage.

3.1.19**containment device**

Seal or bushing that is intended to manage leakage from the inner or outer seal and divert it to a location determined by the user.

See Annex F for further description.

3.1.20**containment seal**

Special version of an outer seal used in Arrangement 2 and that normally operates in a vapor (gas buffer or no buffer) but will seal the process fluid for a limited time in the event of an inner seal failure. See 4.1.4.

3.1.21**containment seal chamber**

Component or aggregate of components that form the cavity into which the containment seal is installed.

3.1.22**containment seal chamber leakage collector**

Reservoir connected by pipework to the containment seal chamber for the purpose of collecting condensed leakage from the inner seal of an Arrangement 2.

3.1.23**crystallizing fluid**

Fluid that is in the process of forming solids or that may form solids because of dehydration or chemical reaction and can also be caused by a change of state such as CO₂.

3.1.24**distributed flush system**

Arrangement of holes, passages, baffles, etc. designed to promote an even distribution of flush fluid around the circumference of the seal faces.

NOTE These are normally required when piping plans provide flush into the seal chamber.

3.1.25**drive collar**

External part of the seal cartridge that transmits torque to the seal sleeve and prevents axial movement of the seal sleeve relative to the shaft.

3.1.26**dual mechanical seal**

Arrangement 2 or Arrangement 3 seal of any type.

3.1.27**dynamic sealing pressure rating**

Highest pressure differential that the seal assembly can continuously withstand at the maximum allowable temperature while the shaft is rotating.

NOTE Thereafter, the seal retains its static sealing pressure rating.

3.1.28**dynamic secondary seal**

Secondary seal that is designed to slide or move relative to other components to allow axial movement of the flexible element.

3.1.29**engineered seal**

Mechanical seal for applications with service conditions outside the scope of this standard.

NOTE Engineered seals are not required to meet any of the design or testing requirements of this standard. See 4.1.3 and A.1.2.

3.1.30**external circulating device**

Device located outside of the seal/buffer/barrier chamber to circulate seal chamber fluid through a cooler or through a dual mechanical seal.

3.1.31**face-to-back configuration**

Dual seal in which one mating ring is mounted between the two flexible elements and one flexible element is mounted between the two mating rings and the pump process fluid is on the OD of the inner seal and barrier or buffer fluid is on the ID of the inner seal and OD of the outer seal.

3.1.32**face-to-face configuration**

Dual seal in which both of the mating rings are mounted between the flexible elements.

3.1.33**fixed bushing**

Cylindrical device with a close clearance to the shaft or sleeve that restricts flow between two regions and that does not have a clearance on the outer diameter relative to the housing in which it is mounted.

3.1.34**fixed throttle bushing**

One-piece cylindrical device that is fitted to the stationary part of the containment seal chamber and has a radial clearance to a rotating component; it is used to help isolate one region from another and assist in channeling liquid leakage to an exit port, and the design is intended to maintain a fixed radial clearance over the operating life of the seal, these devices have a low L/D ratio 0.2 or lower.

3.1.35**flashing**

Rapid change in fluid state from liquid to gas.

NOTE In a dynamic seal, this can occur when frictional energy is added to the fluid as it passes between the primary seal faces, or when fluid pressure is reduced below the fluid's vapor pressure because of a pressure drop across the seal faces.

3.1.36**flashing hydrocarbon**

flashing fluid

Liquid hydrocarbon or other fluid with an absolute vapor pressure greater than 0.1 MPa (1 bar) (14.7 psi) at the pumping temperature, or a fluid that will readily boil at ambient conditions.

3.1.37**flexible element**

Combination of elements that accommodate axial movement between rotating and stationary parts.

3.1.38**flexible graphite**

Exfoliated and recompressed graphite material used for static (secondary seal) gaskets in mechanical seal design, from cryogenic to hot service.

3.1.39**floating bushing**

Cylindrical device with a close clearance to the shaft or sleeve that restricts flow between two regions and that has a clearance on the outer diameter relative to the housing in which it is mounted to allow radial motion ("floating") of the bushing should it come in contact with the rotating shaft or sleeve.

3.1.40**fluoroelastomer**

FKM

Saturated polymer in which hydrogen atoms have been replaced with fluorine; it is characterized by excellent hydrocarbon and general chemical resistance.

3.1.41

flush, noun

Fluid that is introduced into the seal chamber on the process fluid side in close proximity to the seal faces and typically used for cooling and lubricating the seal faces and/or to keep them clean.

3.1.42**gland plate**

gland end plate

Pressure-retaining component(s) similar to a flange, which connects the stationary assembly of a mechanical seal to the seal chamber.

NOTE A gland plate may consist of more than one pressure-containing component, for example the two gland plates often used in a dual seal.

3.1.43**hook sleeve**

Sleeve, with a step or hook at the product end, placed over the shaft to protect it from wear and corrosion.

NOTE The step is usually abutted against the impeller to hold it in place with a gasket between the shaft and the step (hook).

3.1.44**inner seal**

(Arrangement 2 and Arrangement 3) The seal closest to the pump impeller or process fluid.

3.1.45**internal circulating device**

Device located in the seal/buffer/barrier chamber to circulate fluid through a cooler or through a dual mechanical seal.

NOTE There are various designs to achieve radial or axial flow. The internal circulating device can be integral with other seal parts or a separate part. (This device was formerly known as a "pumping ring.")

3.1.46**internally mounted seal**

Seal configuration in which the seal is mounted within the boundaries of the seal chamber or containment seal chamber or gland plate.

3.1.47**leakage concentration**

Measure of the concentration of a volatile organic compound or other regulated emission in the environment immediately surrounding the seal.

3.1.48**leakage rate**

Volume or mass of fluid passing through a seal in a given length of time.

3.1.49**light hydrocarbon**

Hydrocarbon liquid that will readily boil at ambient conditions.

NOTE Typically this definition includes pure and mixed streams of pentane (C₅) and lighter liquids.

3.1.50**mating ring**

Disk- or toroidal-shaped member, mounted either on a sleeve or in a housing such that it does not move axially relative to the sleeve or the housing on or in which it is mounted and that provides the mating seal face for the seal ring face, the mating seal face is perpendicular to the axis of the shaft.

3.1.51**maximum allowable temperature**

Maximum continuous temperature for which the manufacturer has designed the equipment (or any part to which the term is referred) when handling the specified fluid at the specified maximum operating pressure.

NOTE 1 This information is supplied by the seal manufacturer.

NOTE 2 The maximum allowable temperature is usually set by material considerations. This may be the material of the casing or a temperature limit imposed by a gasket or O-ring. The yield strength and ultimate strength are temperature dependent. A component's stress level can depend on operating pressure. Thus, the margin between the strength limit of the material and the operating stress depends on both the material's operating temperature and the component's stress level. If the temperature is lowered, the material's strength increases and the stress level of the component may increase. This is the reason for associating the maximum allowable temperature to the maximum specified operating pressure.

3.1.52
maximum allowable working pressure
MAWP

Maximum continuous pressure for which the manufacturer has designed the equipment (or any part to which the term is referred) when handling the specified fluid at the specified maximum operating temperature [cf. **static sealing pressure rating** (3.1.84), **dynamic sealing pressure rating** (3.1.27)].

3.1.53
maximum dynamic sealing pressure
MDSP

Highest pressure expected at the seal (or seals) during any specified operating condition and during start-up and shutdown.

NOTE In determining this pressure, consideration is given to the maximum suction pressure, the flush pressure, and the effect of clearance changes within the pump. This is a process condition and is specified by the purchaser.

3.1.54
maximum operating temperature

Maximum temperature to which the seal (or seals) can be subjected.

NOTE This is a process condition and is specified by the purchaser.

3.1.55
maximum static sealing pressure
MSSP

Highest pressure, excluding pressures encountered during hydrostatic testing, to which the seal (or seals) can be subjected while the pump is shut down.

NOTE This is a process condition and is specified by the purchaser.

3.1.56
noncontacting seal
self-acting seal

Seal design in which the faces are designed to intentionally create aerodynamic or hydrodynamic separating forces to sustain a specific separation gap between the seal ring and the mating ring.

NOTE Noncontacting seals are specifically designed so that there is always an operating gap between the stationary and rotating face.

3.1.57
nonflashing hydrocarbon
nonflashing fluid

Liquid hydrocarbon or other fluid whose vapor pressure at any specified operating temperature is less than an absolute pressure of 0.1 MPa (1 bar) (14.7 psi), or a fluid that will not readily boil at ambient conditions.

3.1.58**nonhydrocarbon service**

Service in which the fluid, such as sour water, boiler feed water, sodium hydroxide, acids, and amines, contains no hydrocarbons or the fluid has relatively small quantities of entrained hydrocarbons.

3.1.59**observed test**

Product test that is observed at the discretion of the purchaser, who has been given notice of the test by the manufacturer, but does not constitute a manufacturing hold point.

3.1.60**orifice nipple**

Pipe nipple made of solid bar stock with an orifice hole drilled through it to restrict leakage in the event of an auxiliary system pipe or component failure.

NOTE Orifice nipples are commonly found on Piping Plan 11 systems.

3.1.61**O-ring**

Elastomeric sealing ring with an O-shaped (circular) cross-section, which may be used as either a static or dynamic secondary seal.

3.1.62**outer seal**

(Arrangement 2 and Arrangement 3) The seal located farthest from the pump impeller or process fluid.

3.1.63**perfluoroelastomer****FFKM**

Fully fluorinated fluorocarbon elastomer commonly used as a secondary seal in high-temperature and/or corrosive service.

3.1.64**pipng plan**

Configuration of accessories, instruments, controls, and/or fluids designed to manage or control the environment around the seal.

NOTE Auxiliary piping plans vary with the application, seal type, and arrangement.

3.1.65**polymerizing fluid**

Fluid that is in the process of changing, or is capable of changing, from one chemical composition to another with longer-chain components and different properties, usually becoming significantly more viscous and/or tacky.

3.1.66**port**

Fluid passageway, typically located in the gland plate.

3.1.67**pressure casing**

Composite of all the stationary pressure-containing parts of the seal, including seal chamber barrier or buffer fluid chamber, containment seal chamber, and seal gland plate, and excluding seal ring, mating ring, bellows, sleeves, miscellaneous internal seal parts, and atmospheric side gland connections, which cannot be isolated from atmospheric pressure.

NOTE The MAWP of the auxiliary system is specified in Section 8.

3.1.68**product temperature margin**

Difference between the vaporization temperature of the fluid at the seal chamber pressure and the actual temperature of the fluid.

NOTE For pure fluids, the vaporization temperature is the saturation temperature at seal chamber pressure; for mixed fluids, the vaporization temperature is the bubble point temperature at the seal chamber pressure.

3.1.69**pump manufacturer**

Agency that designs, manufactures, tests, and provides service support for the pump.

NOTE The pump manufacturer may also purchase the sealing system and perform the installation.

3.1.70**pumped fluid**

process fluid

The process stream designated in the datasheet for the pump service.

3.1.71**purchaser**

Agency that issues the order and specifications to the vendor.

3.1.72**pusher seal**

Seal that incorporates a dynamic secondary seal to allow axial movement of the flexible element; the axial movement is driven (pushed) by mechanical and/or hydraulic force.

3.1.73**quench**, noun

Neutral fluid, usually water, steam, or nitrogen, introduced on the atmospheric side of the seal to retard formation of solids that may interfere with seal movement, or for other purposes such as prevention of coking, crystallization, or icing.

3.1.74**seal**

end face mechanical seal

Device that prevents the leakage of fluids between a shaft and housing in relative motion.

NOTE Sealing is accomplished by a stationary seal face bearing against a rotating seal face; the sealing faces are mounted perpendicular to the shaft axis.

3.1.75**seal balance ratio**

Ratio of seal face area exposed to closing force by hydraulic differential pressure across the seal face to the total seal face area (see Annex F).

NOTE It is sometimes expressed as a percentage.

3.1.76**seal chamber**

Component, either integral with or separate from the pump case (housing), which forms the region between the shaft and casing into which the seal is installed.

3.1.77**seal face**

seal faces

The lapped surface of a mating ring or seal ring that comes in contact or close proximity to the other ring and provides the relative rotary motion sealing surface(s).

3.1.78**seal manufacturer**

Agency that designs, manufactures, tests, and provides service support for seals and associated support sealing systems.

3.1.79**seal ring**

Disk- or toroidal-shaped member, mounted either on a sleeve or in a housing such that it is able to move axially relative to the sleeve or the housing on or in which it is mounted and that provides the mating seal face for the mating ring face, the seal ring face is perpendicular to the axis of the shaft.

3.1.80**seal sleeve**

Hollow cylindrical component that fits on the outer diameter of the shaft with a close tolerance fit, incorporates a static secondary seal with the shaft and extends beyond the seal gland plate, it is used in the assembly of the seal components and ensures they rotate with the shaft.

3.1.81**secondary seal**

Device (such as an O-ring, flexible graphite ring, flexible graphite filled spiral wound gasket, or bellows) that prevents leakage of the sealed fluid, barrier fluid, buffer fluid, or quench medium through paths other than the inner or outer seal faces, the containment device, or designated drain.

3.1.82**segmented floating bushing**

Throat or throttle bushing that is composed of circumferential segments retained by a tensioning device.

3.1.83**service condition**

Maximum or minimum temperature or pressure under static or dynamic conditions.

3.1.84**static sealing pressure rating**

Highest pressure that the seal can continuously withstand at the maximum allowable temperature while the shaft is not rotating.

NOTE Thereafter, the seal maintains its dynamic sealing pressure rating.

3.1.85**static secondary seal**

Secondary seal between two surfaces that have no relative motion.

3.1.86**strainer**

A relatively low pressure drop device designed to remove solid particles from the flush or other fluid.

3.1.87**throat bushing**

Device that forms a restrictive close clearance around the sleeve (or shaft) between the seal chamber and the impeller.

**3.1.88
throttle bushing**

Containment device that forms a restrictively close clearance around the sleeve at the atmospheric end of a gland plate.

**3.1.89
total indicator reading**

total indicated runout

TIR

Difference between the maximum and minimum readings of a dial indicator or similar device when monitoring a face or cylindrical surface during one complete revolution of the monitored surface.

NOTE For a perfectly cylindrical surface, the indicator reading implies an eccentricity equal to half the reading. For a perfectly flat face, the indicator reading gives an out-of-squareness equal to the reading. If the diameter in question is not perfectly cylindrical or flat, interpretation of the meaning of TIR is more complex, and may represent ovality or lobing.

**3.1.90
Type A seal**

See 4.1.3.

**3.1.91
Type B seal**

See 4.1.3.

**3.1.92
Type C seal**

See 4.1.3.

**3.1.93
vendor**

Manufacturer of the equipment, or his/her agent, normally responsible for service support.

NOTE This standard addresses the responsibilities between two parties, defined as the purchaser and the vendor. There are many parties that are involved in the purchase and manufacture of the equipment. These parties are given different titles depending on their order in the chain. They may be called buyer, contractor, manufacturer, or subvendor. For example, the party supplying a lubricating oil console may be the console vendor of the compressor manufacturer, the subvendor of the purchaser, and the purchaser of components within the console. All of these terms, however, can be reduced to the purchaser and vendor. It is for this reason that only these two terms are defined. Attempts to define these other terms would only cause confusion.

**3.1.94
volatile hazardous air pollutant
VHAP**

Any compound as defined by Title 1, Part A, Section 112 of the *U.S. National Emission Standards for Hazardous Air Pollutants (NESHAPs) (Clean Air Act Amendment)*.

**3.1.95
witnessed inspection**

witnessed test

Inspection or test for which the purchaser is notified of the timing and a hold is placed on production until the purchaser or his/her representative is in attendance.

3.2 Symbols

For the purposes of this document, the following symbols apply.

A the area of the seal face, expressed in square millimeters

F_O	the opening force, expressed in Newtons
f	the effective coefficient of friction
K	the pressure drop coefficient, dimensionless
$V\%_{AB}$	volume percentage of component A in mixture B
Δp	the differential pressure, expressed in megapascals
ρ_A	density (specific gravity) of fluid A
ρ_B	density (specific gravity) of fluid B
ω_{AB}	mass percentage of component A in mixture B

4 Sealing Systems

4.1 Seal Categories, Types, and Arrangements

4.1.1 General

The seal configurations covered by this standard can be classified into three categories (1, 2, and 3), three types (A, B, and C) and three arrangements (1, 2, and 3). Further, Arrangement 2 and 3 seals can be in three orientations: “face-to-back,” “back-to-back,” and “face-to-face.” These categories, types, arrangements, and orientations are defined below.

See Figure 1, Figure 2, Figure 3, Figure 4, Figure 5, Figure 6, Figure 7, Figure 8, and Figure 9 for typical representations.

4.1.2 Seal Categories

There are three seal categories, as follows.

- *Category 1* seals are intended for use in non-API 610 pump seal chambers, meeting the dimensional requirements of ASME B73.1, and ASME B73.2 seal chamber dimensions and their application is limited to seal chamber temperatures from $-40\text{ }^{\circ}\text{C}$ ($-40\text{ }^{\circ}\text{F}$) to $260\text{ }^{\circ}\text{C}$ ($500\text{ }^{\circ}\text{F}$) and gauge pressures up to 2 MPa (20 bar) (300 psi).
- *Category 2* seals are intended for use in seal chambers meeting the chamber envelope dimensional requirements of API 610. Their application is limited to seal chamber temperatures from $-40\text{ }^{\circ}\text{C}$ ($-40\text{ }^{\circ}\text{F}$) to $400\text{ }^{\circ}\text{C}$ ($750\text{ }^{\circ}\text{F}$) and gauge pressures up to 4 MPa (40 bar) (600 psi).
- *Category 3* provides the most rigorously tested and documented seal design. They meet the seal chamber envelope requirements of API 610 (or equal). Their application is limited to seal chamber temperatures from $-40\text{ }^{\circ}\text{C}$ ($-40\text{ }^{\circ}\text{F}$) to $400\text{ }^{\circ}\text{C}$ ($750\text{ }^{\circ}\text{F}$) and gauge pressures up to 4 MPa (40 bar) (600 psi).

A summary of the main differences in seal categories is given in Annex A.

Temperatures and pressures outside the ranges of these categories, or which involve fluids not included in Annex A, may require engineering and seal selection guidance other than provided in this standard.

4.1.3 Seal Types

There are three seal types, as follows.

- *Type A* seal is a balanced, internally-mounted, cartridge design, pusher seal with multiple springs. Secondary sealing elements are elastomeric O-rings.

Materials are specified in Section 6. Guidance on equivalent materials standards is given in Annex B. Figure 7 depicts a Type A seal.

- *Type B* seal is a balanced, internally-mounted, cartridge design (metal bellows) seal. Secondary sealing elements are elastomeric O-rings.

Materials are specified in Section 6. Guidance on equivalent materials standards is given in Annex B. Figure 8 depicts a Type B seal. A metal bellows seal offers the advantage of having only static secondary seals. It may be specified instead of the default Type A seal for low-temperature service.

- *Type C* seal is a balanced, internally-mounted, cartridge design (metal bellows) seal. Secondary sealing elements are flexible graphite.

Materials are specified in Section 6. Guidance on equivalent materials standards is given in Annex B. Figure 9 depicts a Type C seal. Bellows seals are inherently balanced. Stationary metal bellows seals are the primary choice for high-temperature Arrangement 1 seals.

Type A and Type B seals are suitable for temperatures up to 176 °C (350 °F). Type C seals are for high temperatures up to 400 °C (750 °F). Seals outside the scope of Type A, B, and C are termed engineered seals and referred to as ES.

NOTE For Seal Arrangement 2 and Arrangement 3 the seal types can be mixed across configurations.

4.1.4 Seal Arrangements

4.1.4.1 Arrangement 1, 2, and 3 Seals

There are three seal arrangements, as follows.

- *Arrangement 1*—Seal configurations having one seal per cartridge assembly.
- *Arrangement 2*—Seal configuration having two seals per cartridge assembly, with the space between the seals at a pressure less than the seal chamber pressure.
- *Arrangement 3*—Seal configurations having two seals per cartridge assembly, utilizing an externally supplied barrier fluid at a pressure greater than the seal chamber pressure.

NOTE 1 The principal difference between Arrangement 2 and Arrangement 3 configurations is the concept of containment of leakage versus the elimination of process fluid leakage. Refer to the associated definitions and Annex G piping plan descriptions.

NOTE 2 In Arrangement 2, the outer seal can be a wet seal or a dry-running seal. The inner seal utilizes a piping plan typical of Arrangement 1 seals. If the outer seal is a wet seal design, an unpressurized liquid buffer fluid is supplied to the outer seal chamber. If the outer seal is a dry-running seal it is defined as a containment seal (3.1.20); a gas buffer may be used.

4.1.4.2 Alternate Technology Designs and Sealing Methods

Alternative technology designs and sealing methods are also considered, as follows.

- *Contacting wet (CW) seals*—Seal design where the seal faces are not designed to intentionally create aerodynamic or hydrodynamic forces to sustain a specific separation gap (refer to 3.1.18).
- *Noncontacting (NC) seals (whether wet or dry)*—Seal design where the seal faces are designed to intentionally create aerodynamic or hydrodynamic separating forces to sustain a specific separation gap (refer to 3.1.56).
- *Containment seals (CS), whether contacting or noncontacting*—Seal design with one flexible element, seal ring and mating ring mounted in the containment seal chamber (refer to 3.1.20).

Figure 1 places all these concepts in one diagram, providing a comprehensive way to look at their interrelationships.

4.1.5 Seal Configurations

Arrangement 2 and Arrangement 3 seals can be in the following three configurations:

- face-to-back: refer to 3.1.31;
- back-to-back: refer to 3.1.7;
- face-to-face: refer to 3.1.32;

Refer to Figure 1.

Other configuration such as concentric seals may be agreed by the purchaser and vendor and are considered an engineered seal.

4.2 Objectives

Shaft sealing systems conforming to this standard are intended to meet the following objectives:

- a) all seals should operate continuously for 25,000 h without need for replacement;
- b) Arrangement 2 outer seals should operate for at least 25,000 h without need for replacement (wet or dry seals) at any containment seal chamber or buffer fluid chamber pressure equal to or less than the seal leakage pressure switch setting [not to exceed a gauge pressure of 0.07 MPa (0.7 bar) (10 psi)] and for at least 8 h at the seal chamber conditions;
- c) all seals should operate for 25,000 h without need for replacement while either complying with local emissions regulations, or exhibiting a maximum screening value of 1,000 ml/m³ (1,000 ppm vol) as measured by the EPA Method 21, whichever is more stringent.

4.3 Specifying and/or Purchasing a Sealing System

The datasheet (Annex C) shall be used to convey purchasing requirements. Default requirements are identified therein that allow the purchaser to specify a seal with minimum information. The minimum data required on the datasheet to obtain budgetary pricing on a sealing system is expressed in the seal code. Typical seal codes that can be used are given in Annex D. This assumes all standard defaults (construction features and materials). The minimum information required on the datasheet to purchase a seal with assurance that the selection will satisfy the objectives of 4.2 is the pump data, fluid data, and seal specification.

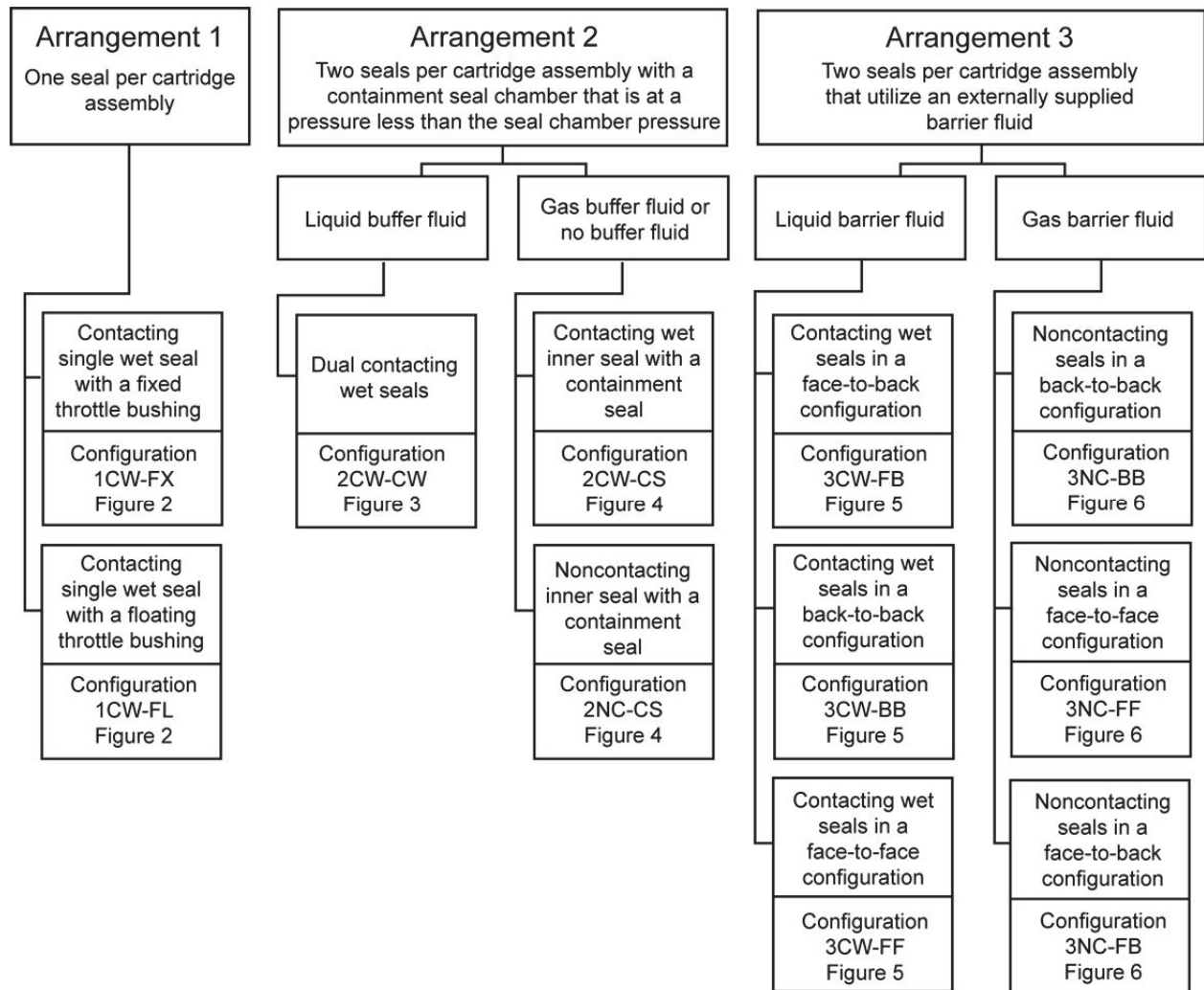
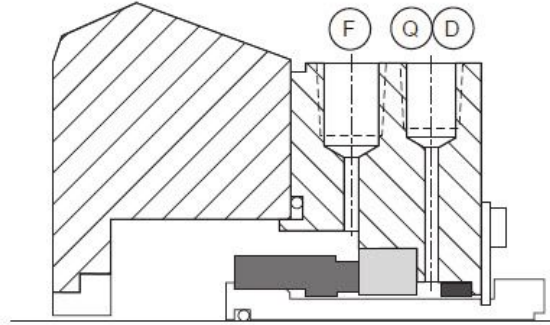
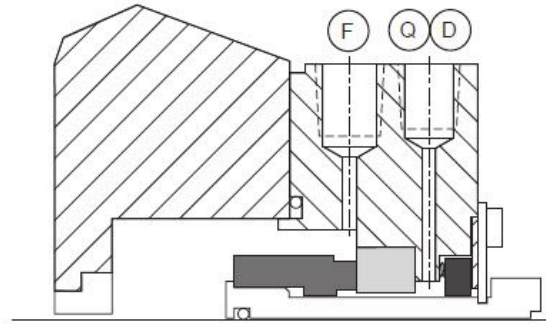

Figure 1—Seal Configurations



a) 1CW-FX, Contacting Single Wet Seal with a Fixed Throttle Bushing



b) 1CW-FL, Contacting Single Wet Seal with a Floating Throttle Bushing

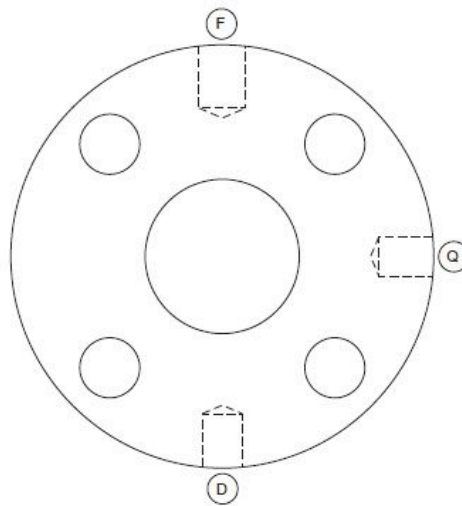

c) Typical Gland Plate Connection Orientation

NOTE For connection designations, see Table 2.

Figure 2—Arrangement 1: One Seal per Cartridge Assembly

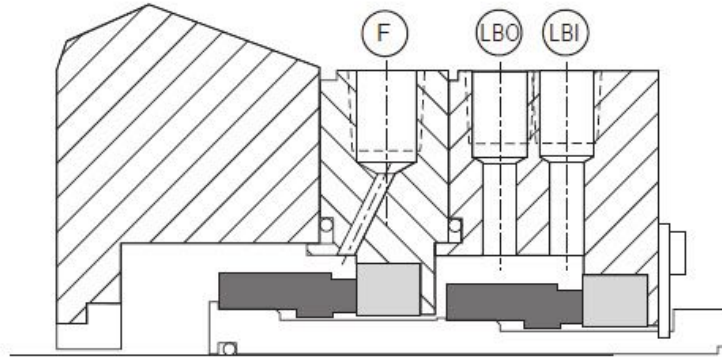

a) 2CW-CW, Dual Contacting Wet Seal

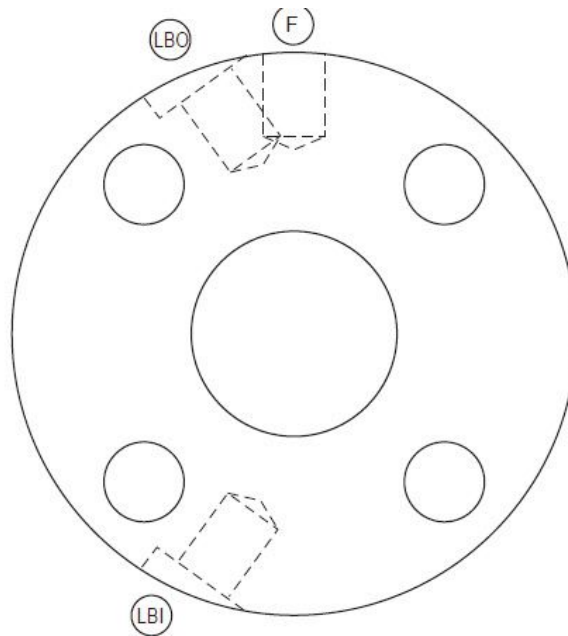

b) Typical Gland Plate Connection Orientation

NOTE For connection designations, see Table 2.

Figure 3—Arrangement 2: Two Seals per Cartridge Assembly with a Liquid Buffer Fluid

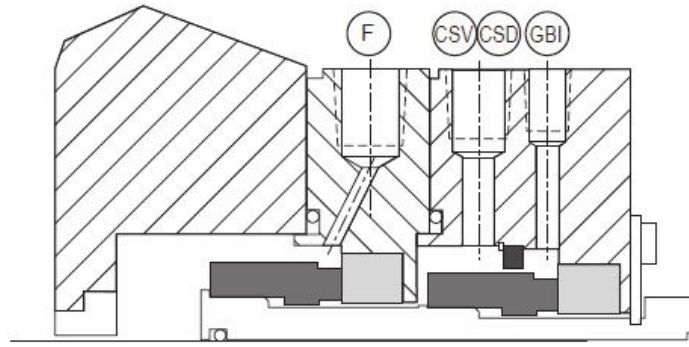

a) 2CW-CS, Contacting Wet Inner Seal with a Containment Seal

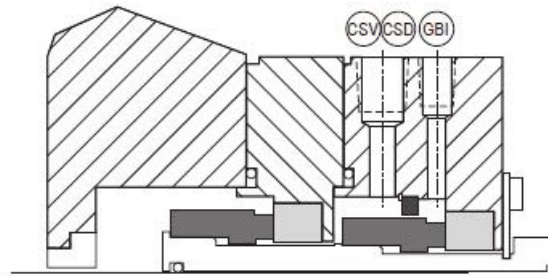

b) 2NC-CS, Noncontacting Inner Seal with a Containment Seal

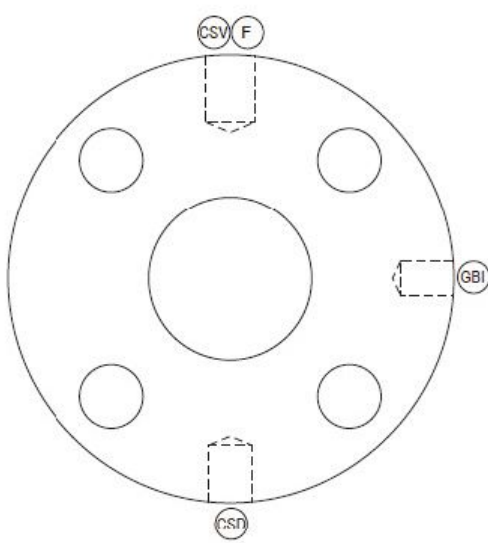

c) Typical Gland Plate Connection Orientation for 2CW-CS

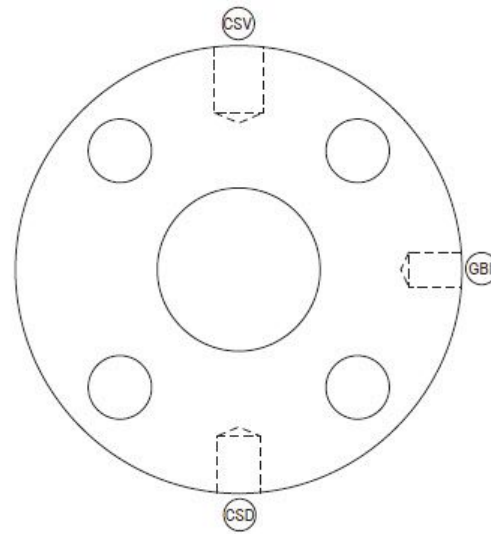

d) Typical Gland Plate Connection Orientation for 2NC-CS

NOTE For connection designations, see Table 2.

Figure 4—Arrangement 2: Two Seals per Cartridge Assembly with or Without a Gas Buffer Fluid

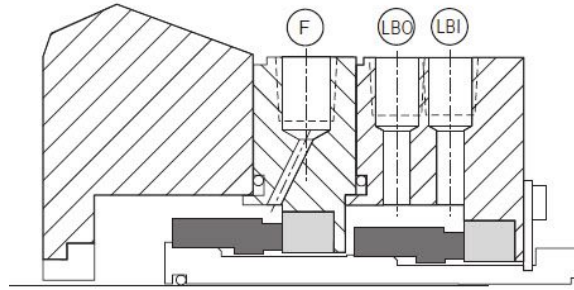

a) 3CW-FB, Contacting Wet Seals in a Face-to-Back Configuration

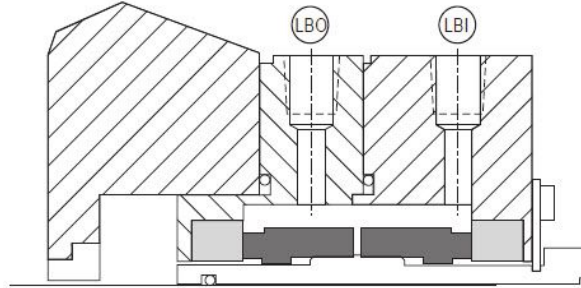

b) 3CW-BB, Contacting Wet Seals in a Back-to-Back Configuration

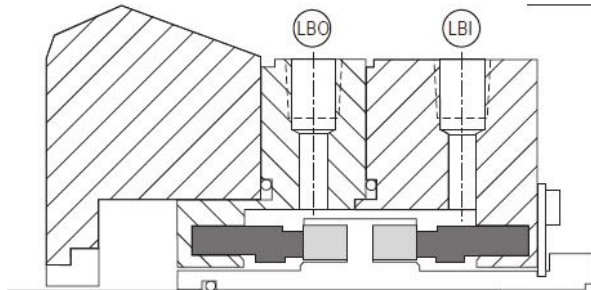

c) 3CW-FF, Contacting Wet Seals in a Face-to-Face Configuration

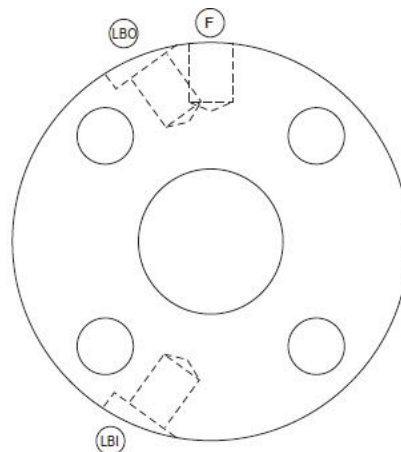

d) Typical Gland Plate Connection Orientation

NOTE For connection designations, see Table 2.

Figure 5—Arrangement 3: Two Seals per Cartridge Assembly with a Liquid Barrier Fluid

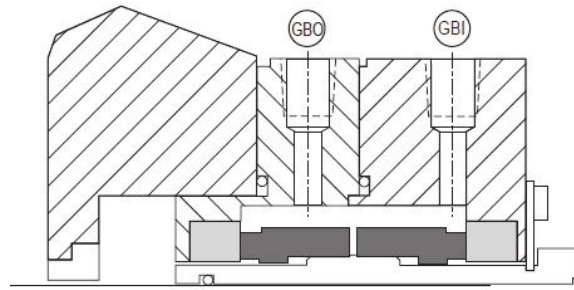

a) 3NC-BB, Noncontacting Seals in a Back-to-Back Configuration

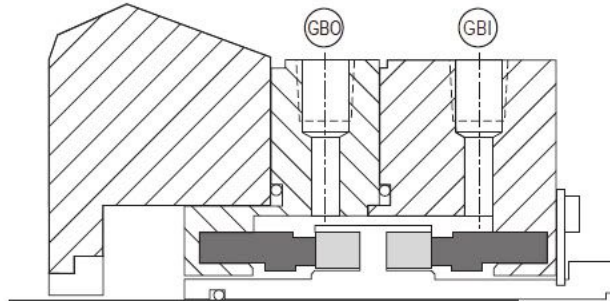

b) 3NC-FF, Noncontacting Seals in a Face-to-Face Configuration

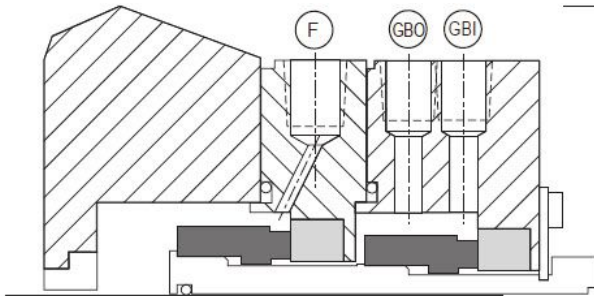

c) 3NC-FB, Noncontacting Seals in a Face-to-Back Configuration

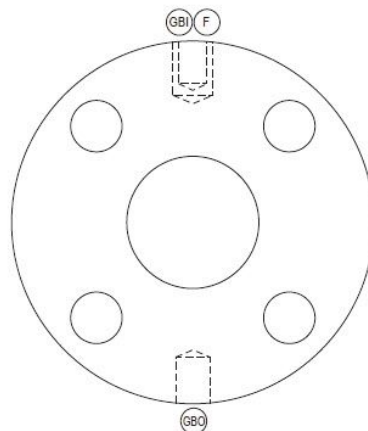

d) Typical Gland Plate Connection Orientation

NOTE For connection designations, see Table 2.

Figure 6—Arrangement 3: Two Seals per Cartridge Assembly with a Gas Barrier Fluid

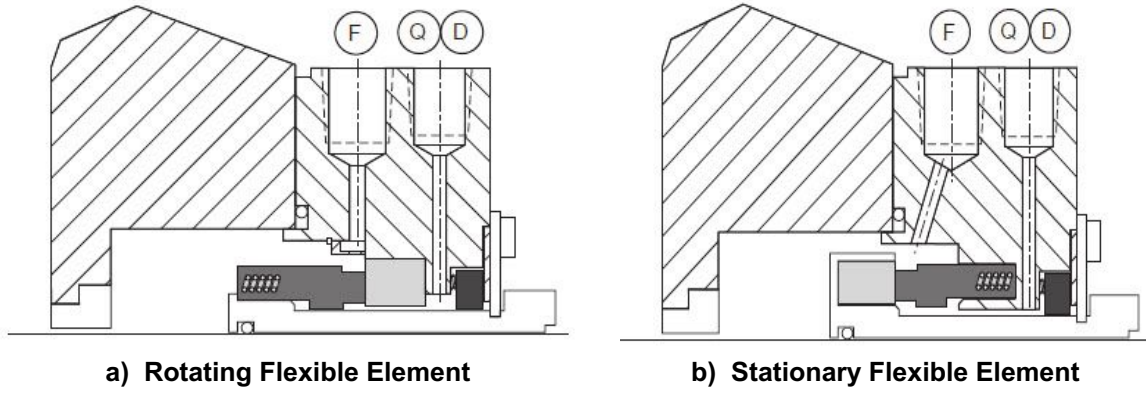

Figure 7—Arrangement 1 Type A Seals

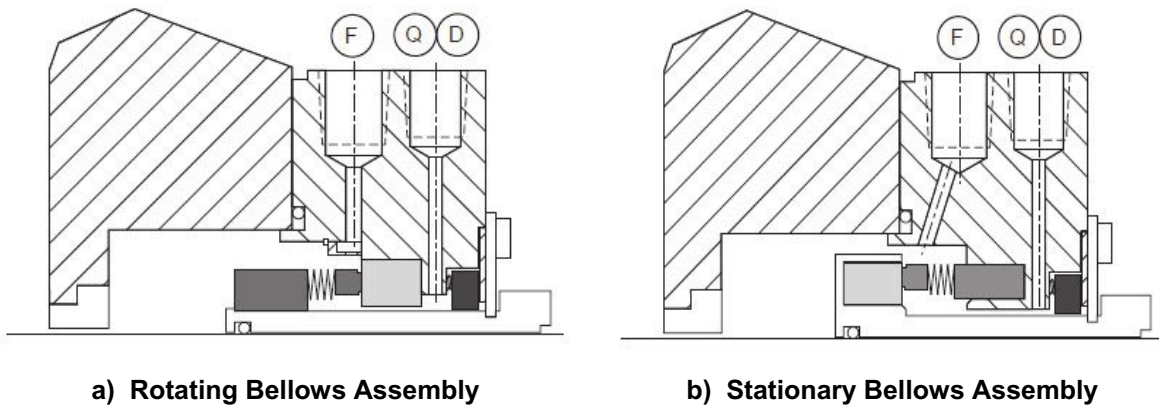

Figure 8—Arrangement 1 Type B Seals

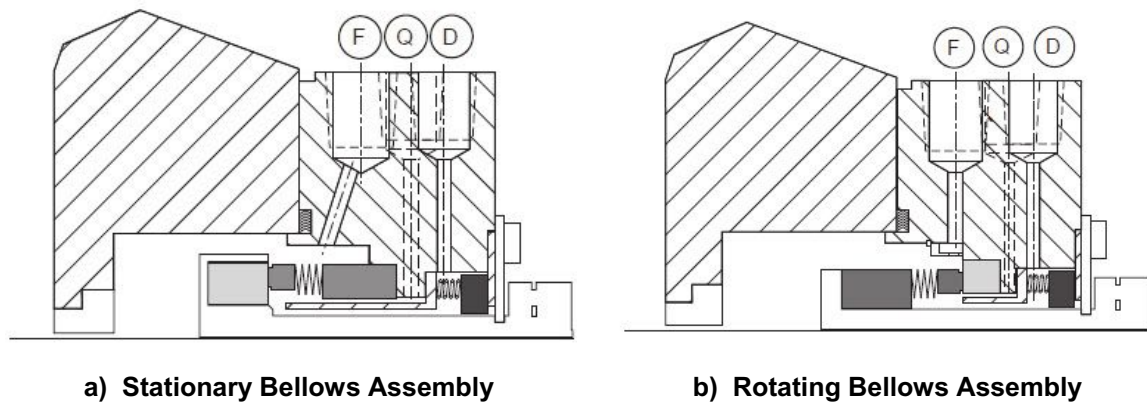

Figure 9—Arrangement 1 Type C Seals

5 General

5.1 Unit Responsibility

Unless otherwise specified, the pump vendor shall have unit responsibility for the seal system if the seal system is purchased as part of a pump system. If not purchased as part of a pump system, the seal vendor shall have unit responsibility for the seal system. The vendor who has unit responsibility shall ensure that all subvendors comply with the requirements of this standard. Annex E specifies the interface responsibilities of the pump and seal vendors.

5.2 Dimensions

- The purchaser shall specify whether data, drawings, hardware (including fasteners), and equipment supplied to this standard shall use SI units (or U.S. Customary units).

6 Design Requirements

6.1 Common Design Requirements (All Categories)

6.1.1 General Information

6.1.1.1 All mechanical seals, regardless of type or arrangement, shall be of the cartridge design, without hook sleeves.

API 610 requires that pumps be designed to enable seal removal without disturbing the driver. If pumps are being retrofitted that are not back-pullout design, it should be verified that adequate shaft end spacing exists by comparing the seal cartridge length to the distance between shaft ends.

- **6.1.1.2** Unless otherwise specified the flexible element shall be rotating for Type A and Type B seals. If specified, or if recommended by the seal manufacturer and agreed by the purchaser, a stationary flexible element shall be supplied for Type A or Type B seals.

NOTE Within the scope of this standard, rotating and stationary flexible elements are considered to be technically equivalent, but the optimum choice is influenced by many different factors. The default for rotating or stationary elements for different seal types and their arrangements have been based on installed population and reliable operation.

There are a number of factors related to the design, manufacture, installation, and repair of the equipment that should be considered when making the selection of a rotating or stationary flexible element. The relative merits of rotary and stationary flexible element seals and the factors influencing the choice are addressed in other subsections in this section and F.5.

- **6.1.1.3** Unless otherwise specified the flexible element shall be stationary for Type C seals. If specified or if recommended by the seal manufacturer and agreed by the purchaser a rotating flexible element shall be used for Type C seals.

NOTE See NOTE in 6.1.1.2.

6.1.1.4 The cartridge seal shall incorporate a setting device (such as setting plates) that is sufficiently robust to enable the assembly to be pushed or pulled during installation, rotor adjustment, or disassembly without transferring radial or axial load to the seal faces.

6.1.1.5 A stationary flexible-element seal shall be provided if seal-face surface speed at the mean diameter of the seal face exceeds 23 m/s (4500 ft/min).

NOTE As speed increases, the flexible element of a rotating seal flexes at a correspondingly faster rate to keep the seal faces closed. At very high speeds (and for large seal sizes), the forces required to keep the faces closed become so large that they negatively affect the seal life.

Consideration should be given for requiring a stationary flexible element if:

- a) balance diameter exceeds 115 mm (4.5 in.) (see 6.1.1.7);
- b) pump case or gland plate distortion and misalignment exist due to pipe loads, thermal distortion, pressure distortion, etc.;
- c) the perpendicularity of the seal chamber mounting surface to the shaft is a problem, aggravated by high rotational speed; or
- d) the seal chamber face runout requirements described in 6.1.2.13 cannot be met (as found in ASME B73.1 and ASME B73.2 pumps and with some slender-shaft, multistage pump designs).

6.1.1.6 This standard does not cover the design of the component parts of mechanical seals; however, the design and materials of the component parts shall be suitable for the specified service conditions. The maximum allowable working pressure (MAWP) shall apply to all parts referred to in the definition of pressure casing.

NOTE It is not normal practice for seals to be rated for the MAWP for the pump in which they are installed.

6.1.1.7 The seal manufacturer shall design the seal faces and seal balance ratio to minimize seal-face-generated heat consistent with optimum life expectations in 4.2 and emissions limit requirements. Balance diameter varies with seal design, but for spring pusher seals it is normally the diameter of the sliding contact surface of the dynamic O-ring. For the inner seal of a dual seal the sliding surface can vary depending on whether the pressure is internal or external. For welded metal bellows-type seals, the balance diameter is normally the mean diameter of the bellows, but this will vary with pressure. Contact the seal vendor for determination of the balance diameter under varying pressure conditions.

NOTE 1 Temperature of the environment around the seal as influenced by seal face generated heat and heat soak will have an impact on seal performance. Refer to F.2.1 and F.2.2 for discussion of seal balance diameter, seal generated heat, and heat soak.

NOTE 2 Starting torque and seal power can be significant issues for small pump drivers, seals at or above the balance diameter and pressure boundaries of this standard, and for Arrangement 3 seals.

6.1.1.8 The seal supplied shall be capable of handling normal and transient differential axial movement between the rotor and stator.

NOTE Maximum axial movement is of particular concern in hot multistage pumps. During start-up conditions, it is not unusual for a large amount of differential thermal growth to occur between the shaft and casing. This differential can exceed the capabilities of some seals. Appropriate warm-up procedures can minimize this problem. Axial movement is also a concern in some vertical pump designs that rely on the motor bearing for thrust positioning (i.e. in-line pumps without pump bearing housings and vertical can pumps). In certain conditions, process pressure can result in an upward thrust. Shaft axial movement is only limited by motor-bearing axial float in these cases.

6.1.1.9 Unless otherwise specified, O-ring sealing surfaces, including all grooves and bores, shall have a maximum surface roughness (Ra) of 1.6 μm (63 $\mu\text{in.}$) for static O-rings. The surface against which dynamic O-ring slide shall have a maximum surface roughness of 0.8 μm (32 $\mu\text{in.}$).

Seal to pump interface sealing diameters shall have a minimum 3 mm (0.12 in.) radius or a minimum 1.5 mm (0.06 in.) chamfered lead-in for static O-rings. Chamfers shall have an angle of between 15° and 30°.

Chamfers or radii internal to the cartridge seal shall be adequate to prevent O-ring damage during assembly and shall be identical to the specification used in the qualification test.

NOTE Lead-in chamfers internal to the cartridge seal can vary from the values specified in this section.

6.1.1.10 O-ring grooves shall be sized to accommodate perfluoroelastomer (FFKM) O-rings.

NOTE 1 Some FFKMs have a greater thermal expansion than most other O-ring materials, such as fluoroelastomer (FKM). Installing a FFKM in a groove designed for FKM can lead to damage to the O-ring. On the other hand, FKM O-rings function properly in the larger FFKM grooves. Choosing the wider groove as a standard eliminates this potential cause of O-ring failure and reduces the number of necessary spares.

NOTE 2 The thermal expansion damage in FFKM O-rings is often confused with damage due to chemical-induced swelling of the O-rings and vice versa.

6.1.1.11 For services where the seal chamber pressure can be below atmospheric or for Arrangement 3 inner seal, all seal components shall be designed with a means of retaining the sealing components to prevent them from being dislodged by atmospheric or barrier pressure (see Figure 10 for examples of such designs). The seal design shall be adequate to seal under vacuum conditions when the pump is not operating (see 6.1.2.14.1 for recommended operating conditions).

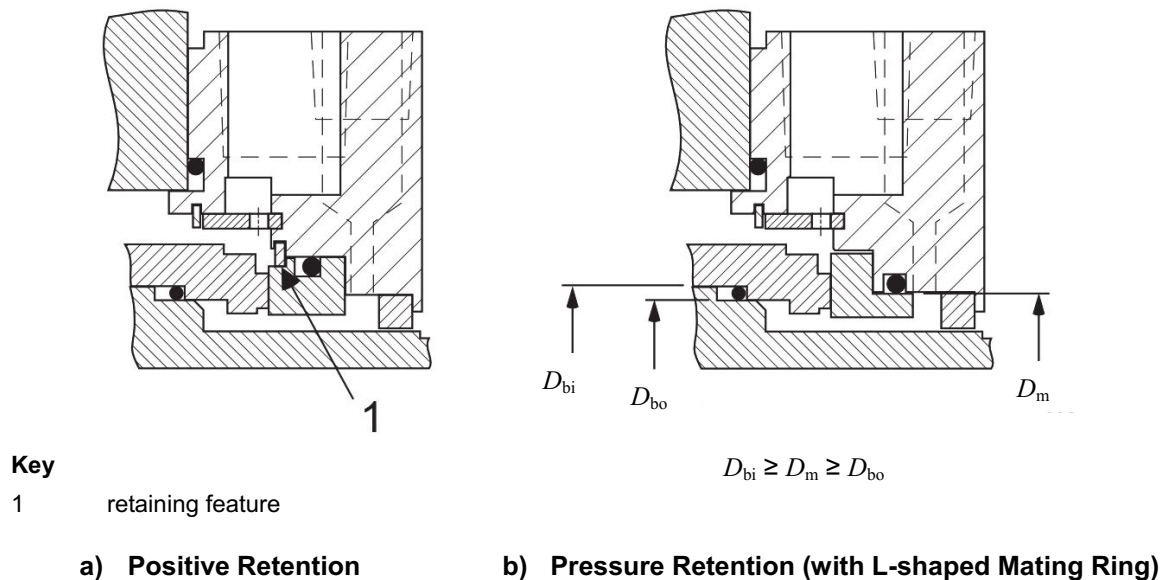

Figure 10—Retention of Seal Components in Vacuum Services and Arrangement 3 Inner Seal

6.1.2 Seal Chamber and Gland Plate

6.1.2.1 Gland plates shall be provided by the seal manufacturer.

6.1.2.2 Unless otherwise specified, seal chambers shall be provided by the pump manufacturer.

6.1.2.3 Seal chambers are one of three types: traditional, externally mounted, or internally mounted. Seal chambers are not required to accommodate packing. Figure 11 shows the three types of seal chamber.

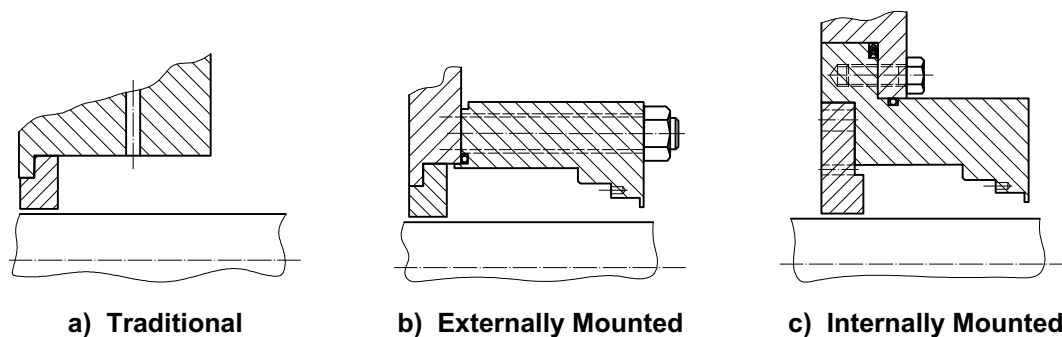

NOTE Type B, the externally mounted seal chamber, offers the most flexibility in terms of its ability to accommodate Arrangement 2 and 3 seals. The seal chamber can be optimized for the axial placement of flush, barrier, and buffer porting facilitating unrestricted flow paths.

Figure 11—Seal Chamber Types

6.1.2.4 The default seal chamber is the traditional type (cylindrical chamber, integral to the casing of the pump) supplied by the pump manufacturer.

Category 1 seals shall be designed to fit into the dimensional envelope defined by ASME B73.1 and ASME B73.2.

Category 2 and Category 3 seals shall be designed to fit into the dimensional envelope of API 610.

Seal chamber designs that utilize all the design features of this standard should result in improved reliability and general standardization of components. Reduced seal radial clearance requires the user to address piping plans and construction requirements for noncompliant seals.

The reliability of a mechanical seal is affected by the radial clearance between its rotating parts and the seal chamber bore. Meeting the minimum radial clearance requirements of this standard is particularly important when sealing difficult services, such as those with significant solids content or those that can result in excessive seal face temperature. Alternative seal chamber designs used in some chemical industry pumps, such as large-bore or tapered seal chambers with flow modifiers, may eliminate the need for a flush or enhance performance based on design of the chamber.

It is expected that the majority of Category 1 seals will be applied to ASME B73.1 and ASME B73.2 pumps, and the majority of Category 2 and Category 3 seals will be installed in API 610 applications. However, there is a recognized possibility that Category 1 seals may be installed in API 610 applications, and Category 2 and Category 3 seals, in certain configurations, may be installed in ASME B73.1 and ASME B73.2 pumps. Careful consideration should be given to correctly applying seal categories into pump types or services for which they are not intended.

- **6.1.2.5** If specified, an internally mounted or externally mounted bolt-on seal chamber shall be provided by the seal manufacturer (Figure 11).

6.1.2.6 The minimum diametral clearance between rotary and stationary components shall be sufficient to prevent contact between parts in relative motion and shall conform to the values in this section and Table 1.

- a) For contacting seals, the minimum diametral clearance between the rotating components of the seal and the stationary surfaces of the seal chamber and gland plate shall be 6 mm ($1/4$ in.) in order to promote fluid circulation and cooling around the seal faces.
- b) For Arrangement 2 or 3 seals where the inner seal is a noncontacting type (2 NC-CS or 3 NC-XX) the minimum diametral clearance between the rotating components of the seal and the stationary surfaces

of the seal chamber and gland plate shall be 3 mm ($1/8$ in.). Non contacting seals generate minimal amount of heat, only that resulting from the viscous shear of the sealed fluid.

- c) The first point of radial contact by a metal component of the seal shall not be at the seal ring or mating ring (see NOTE 2).

NOTE 1 The intent of setting minimal clearances should in no way be construed as implying that any seal component can be used to restrict shaft movement in the event of bearing failure or other machinery or operation problem.

NOTE 2 The requirement in 6.1.2.6 c) is to minimize potential leakage levels and/or a friction generated ignition source in the rare fault event where the relative radial position of the rotating components to the stationary components would be beyond the minimum diametral clearances in Table 1. The importance of having sufficient design clearance to ensure adequate reliability and personal safety in hazardous, toxic and flammable services is paramount. Diametral clearances may be compromised in the event of the following scenarios:

- wear of shaft bearings beyond their design limits;
- operation of the pump beyond its allowable operating range;
- existing pumps that have damaged, corroded, or worn parts that control the radial location of the shaft to the casing.

It is important to ensure pump installation to the appropriate standards on hazardous services. Operational condition monitoring and controlled maintenance and reconditioning procedures are always applied.

NOTE 3 These minimal clearances will be adequate in equipment that is built and/or maintained to the specifications of API 610 and ANSI B73. For other equipment built, repaired, or operated to different specifications these clearances might not be sufficient. Larger clearances should be considered for:

- pump designs unable to conform to the shaft, casing and seal design limits in API 610, API 682, and the shaft/casing limits in ANSI B73.1 and ANSI B73.2. Potentially vulnerable pump designs are discussed in API 610.
- pumps installed with mounting and flange strain, from connecting pipe work, are beyond the recommended limits of API 610 and ANSI B73.1 and ANSI B73.2.

NOTE 4 These minimal clearances are to prevent contact between rotary and stationary parts, but internal clearances in Arrangement 2 and Arrangement 3 CW seals also need to be sufficient to insure proper circulation of the barrier/buffer fluid and cooling of the seal faces. This is particularly important in face-to-back configuration where barrier/buffer fluid circulation to the inner seal is inherently physically remote from the connections. Inadequate cooling of the inner seal can result in reduced seal reliability. Selection of 3CW-BB or 3CW-FF configuration or use of process fluid seal chamber cooling may resolve an inner seal cooling problem.

Table 1—Clearances Between Rotary and Stationary Components

Inside Diameter (ID)	Outside Diameter (OD)	Minimum Diametral Clearance ^a	Reference	
ID seal chamber bore and gland plate	OD rotating seal part	CW seal type	6 mm (0.25 in.)	6.1.2.6.a)
		NC seal type	3 mm (0.125 in.)	
ID stationary seal part	OD rotating seal part	shaft ≤ 60 mm	1 mm (0.039 in.)	6.1.2.6
		shaft > 60 mm	2 mm (0.079 in.)	
ID stationary gland part	OD internal circulation device	shaft ≤ 60 mm	1 mm (0.039 in.)	7.1.2.9
		shaft > 60 mm	2 mm (0.079 in.)	
ID containment fixed bushing 2CW-CS, 2NC-CS	OD rotating seal part	shaft ≤ 60 mm	1 mm (0.039 in.)	7.2.5.1
		shaft > 60 mm	2 mm (0.079 in.)	

^a The minimum diametral clearances are calculated by subtracting the maximum outside diameter (of the internal part) from the minimum inside diameter (of the external part).

Inside Diameter (ID)	Outside Diameter (OD)	Maximum Diametral Clearance ^b	Reference	
ID floating carbon bushing	OD rotating sleeve	20 mm to 50 mm	0.18 mm (0.007 in.)	6.1.2.23
		51 mm to 80 mm	0.225 mm (0.009 in.)	
		81 mm to 125 mm	0.28 mm (0.011 in.)	
ID fixed throttled bushing	OD rotating sleeve	20 mm to 50 mm	0.635 mm (0.025 in.)	6.1.2.22
		51 mm to 75 mm	0.762 mm (0.030 in.)	
		76 mm to 100 mm	0.889 mm (0.035 in.)	
		101 mm to 125 mm	1.016 mm (0.040 in.)	

^b The maximum diametral clearances are calculated by subtracting the minimum outside diameter (of the internal part) from the maximum inside diameter (of the external part).

6.1.2.7 All bolt and stud stresses shall be in accordance with the pressure design code at the MAWP. Four studs shall be used. The diameter of the studs shall be in accordance with the seal chamber dimensional references in 6.1.2.4. Larger studs shall be furnished only if required to meet the stress requirements of EN 13445 or ASME VIII or to sufficiently compress spiral-wound gaskets in accordance with ASME B16.20.

6.1.2.8 The MAWP of the seal pressure casing shall be equal to or greater than that of the pump pressure casing on which it is installed. This value shall be provided by the pump manufacturer. The seal pressure casing shall have a corrosion allowance of 3 mm ($\frac{1}{8}$ in.) and shall have sufficient rigidity to avoid any distortion that would impair seal operation, including distortion that may occur during tightening of the bolts to set gasketing. If approved by the purchaser, a smaller corrosion allowance may be acceptable for some higher alloy materials.

The following shall also apply.

- a) Unless otherwise specified, gland plates shall be provided with holes (not slots) for attachment studs.
- b) Provisions shall be made for centering the seal gland plates and/or chamber with either an inside- or an outside-diameter register fit. The register-fit surface shall be concentric to the shaft and shall have a total indicated runout (TIR) of not more than 0.125 mm (0.005 in.), see Figure 12. The rabbit diametrical clearance shall be H7/f7 in accordance with ISO 286-2.

- c) A shoulder at least 3 mm ($1/8$ in.) thick shall be provided in the seal gland plate to support the axial load generated by seal chamber pressure acting on the seal components see Figure 13.

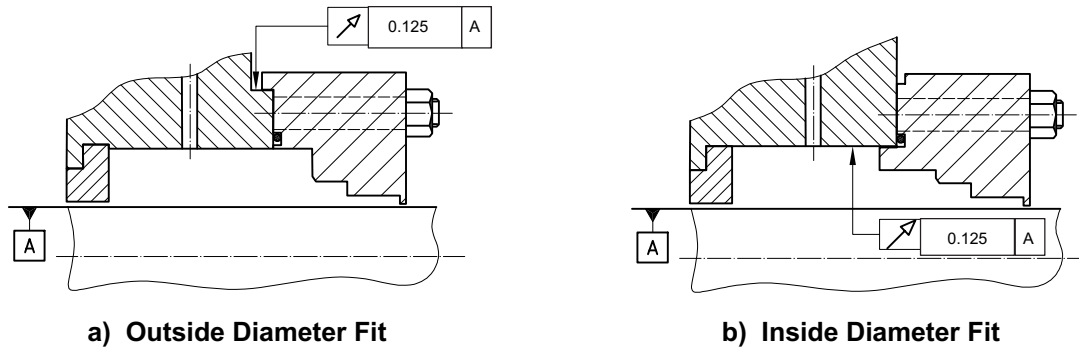
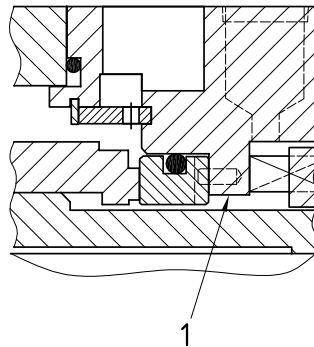

Figure 12—Seal Chamber Register Concentricity



Key

- 1 seal gland plate shoulder

Figure 13—Section Showing Seal Gland Plate Shoulder

6.1.2.9 Stress values used in the design of the pressure casing for any material shall not exceed the values used in the design of the pump casing on which it is installed. Where the original pump design values are not available, the stress values shall be in accordance with API 610.

6.1.2.10 Manufacturing data report forms, third party inspections, and stamping, such as those specified in codes such as ASME VIII, are not required.

6.1.2.11 The use of threaded holes in pressurized parts shall be minimized. To prevent leakage in pressure sections of casing, metal equal in thickness to at least half the nominal bolt diameter, in addition to any corrosion allowance, shall be left around and below the bottom of drilled and tapped holes.

6.1.2.12 Threading details for bolting for pressure casings shall be in accordance with ISO 261, ISO 262, ISO 724, and ISO 965, or with ASME B1.1. Metric fine and UNF threads shall not be used.

Unless otherwise specified, studs in accordance with API 610 Table H.1 shall be used, rather than other fasteners such as cap screws for connection of seal chamber to pump and seal gland plate to pump or seal chamber.

Adequate clearance shall be provided at bolting locations to permit the use of socket or box wrenches.

Manufacturers marking shall be located on all fasteners 6 mm ($1/4$ in.) and larger (excluding washers and headless set screws). For studs, the marking shall be on the nut end of the exposed stud end.

NOTE 1 A set screw is a headless screw with an internal hex opening on one end.

NOTE 2 Adequate clearance to use socket or box wrenches at gland plate bolting locations might not be feasible on small pumps.

6.1.2.13 The seal manufacturer shall design for seal chamber face runout (TIR) up to $0.5 \mu\text{m}/\text{mm}$ (0.0005 in./in.) of seal chamber bore, see Figure 14.

NOTE 1 Some multistage, slender-shaft designs, and some ASME B73 pumps may not be able to meet the requirements of this section (see 6.1.1.5).

NOTE 2 Mechanical seal performance can be adversely affected by excessive runout at the mechanical seal chamber. Seal chamber face runout or seal chamber interface runout is a measure of the squareness of the pump shaft with respect to the face of the seal chamber mounting.

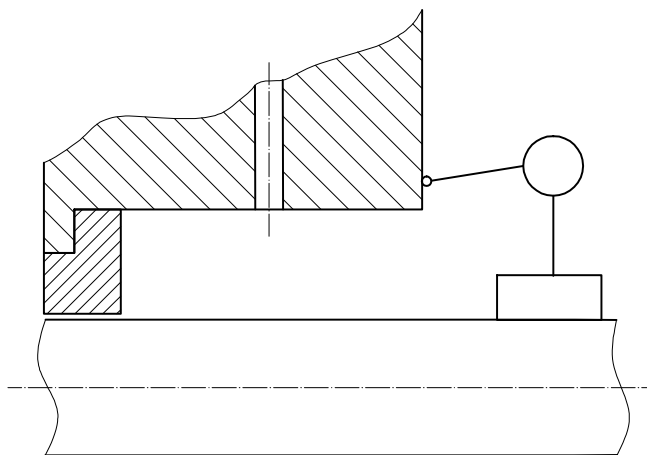

Figure 14—Seal Chamber Face Runout

6.1.2.14 For Arrangement 1 and Arrangement 2, seal chamber pressure and support systems for contacting wet seals (excluding containment seals) shall be designed for proper seal operation. Pumps that develop low differential pressure and pumps that handle high vapor pressure fluids may not achieve the required margins specified in 6.1.2.14.1 and 6.1.2.14.2. If the seal chamber conditions do not meet the specified margins, the seal manufacturer shall:

- a) confirm the adequacy of the seal selection and piping plan based on the specified fluid;
- b) recommend the seal chamber operating conditions (minimum pressure and maximum temperature) that will result in a seal installation that has a high probability of achieving three (3) years of uninterrupted service;
- c) furnish the seal gland plate or seal chamber with a second flush connection to permit measurement of seal chamber pressure directly; and
- d) furnish a distributed flush system unless space limitations preclude its use.

NOTE Refer to F.1.4 for specific recommendations.

6.1.2.14.1 During operation, the seal chamber pressure shall be at least 0.035 MPa (0.35 bar) (5 psi) above atmospheric pressure. This is particularly important if the inlet pressure to the pump is below atmospheric.

6.1.2.14.2 During operation, a vapor pressure margin (VPM) (i.e. the difference between the seal chamber pressure minus the maximum fluid vapor pressure) shall be maintained as required in 6.1.2.14.2 a). If it is not possible to achieve this margin the criteria in 6.1.2.14.2 b) shall be met.

- a) Not less 0.35 MPa (3.5 bar) (50 psi).
- b) A minimum ratio of 1.3 between the absolute pressure in the seal chamber and the absolute vapor pressure of the pumped fluid at pumping temperature.

NOTE 1 For high vapor pressure fluids, (e.g. NGL's like ethane or olefins like ethylene), it is recommended that the user consult the seal vendor for seal design and appropriate VPM.

NOTE 2 For additional guidance on VPM, the user should consult Annex F.1.4.

6.1.2.15 If supplied, throat bushings shall be renewable and designed so that they cannot be forced out by hydraulic pressure.

- **6.1.2.16** If specified, or if recommended by the seal manufacturer, close-clearance floating throat bushings shall be furnished. Materials and clearances shall be suitable for the service and approved by the purchaser.

NOTE Close-clearance throat bushings can be used for any or all of the following purposes along with the appropriate piping plans:

- to increase or decrease seal chamber pressure;
- to isolate the seal chamber fluid; and/or
- to control the flow into or out of the seal chamber.

See F.5.3 for additional guidance concerning the use of throat bushings.

6.1.2.17 Datasheet-specified gland plate and seal chamber connections shall be identified by symbols permanently marked (e.g. stamped or cast) on the component. The symbol, size, and location in Table 2 shall be used (see Figure 15 for the relative axial position of the process and atmospheric connections). Where appropriate, the letters "I" and "O" (marking In and Out) shall be used in conjunction with these markings. For horizontal pumps, 0° is vertical on top. For vertical pumps, the location of the flush (marked with letter "F") connection defines 0° (see Figure 2 to Figure 6). Where the size of the pump or seal gland precludes the inclusion of the required connection on the seal gland, the seal vendor shall advise the pump vendor to include the necessary connection on the pump or seal chamber. If tangential porting is used, the location of the drilled port into the seal chamber shall comply with Table 2. However, the associated locations for the gland plate tapped connections may differ from those specified in Table 2.

The lack of space for tap and port connections in the seal chamber area may require that these be included within the pump manufacturer's scope of supply. Annex E specifies the interface responsibilities of the pump and seal vendors.

Differential sizing minimizes the possibility of improper assembly, particularly during maintenance in the field. The purchaser should be aware that the specified connection size and location in Table 2 might not be practical on smaller pumps.

6.1.2.18 Connection Points and Plugs

6.1.2.18.1 The seal gland threaded connection points shall be plugged with plastic plugs for shipment. These plugs should be international red in color and have a center tab to be easily pulled and distinguished from metal plugs. (See Figure 16.) A warning tag in international yellow color shall be attached to the plugs or seal indicating that the plugs shall be removed prior to operation. The warning tag shall include the international warning symbol and the following text in English, French, Spanish, German,

Japanese, and Mandarin Chinese: "Remove red plug. Install metal plugs or piping as specified on seal drawing." See Figure 16 for an example of such a tag. Plastic plugs, tags, and seal gland plates shall not be painted over on any equipment. Threaded connections other than on the seal gland shall have metal plugs inserted for shipment.

6.1.2.18.2 Metal plugs of the same material as the gland, or with superior corrosion resistance for the intended service, and sufficient in number to plug all openings in the gland plate shall be furnished and packaged separately in a plastic bag with a warning label that all unused seal connections shall be plugged. The same warning shall be included in the seal drawing and instructions. One copy of the seal drawing is to be included in the plastic bag that contains the metal plugs in addition to the copy of the seal drawing that is included in the box with the seal. The metal plugs shall be solid round or solid hexagonal head plugs furnished in accordance with the dimensional requirements of ASME B16.11. Square head plugs shall not be used because of their tendency to be damaged during installation and removal.

NOTE ASME B16.11 is referenced to prevent the supply of hollow or cored plugs; failures of such plugs have occurred within the industry.

6.1.2.18.3 During installation follow plant practices applying a lubricant/sealant on the threads to ensure the threads are vapor tight. Polytetrafluoroethylene (PTFE) tape, antiseize, or antigalling compounds used on gland plate connections can create the possibility of fouling the seal and should be applied with caution.

Category 1 seal gland plates and seal chambers may not be able to meet this standard plug requirement because of space constraints. In such cases, flush-mount socket head plugs are acceptable.

NOTE The head on a pipe plug interferes with the installation and actual ability to fit on many smaller Category 1 pumps if the bearing bracket inner diameter is close in size to the gland plate outer diameter. Also, a head on the plug utilized on the seal chamber port can interfere with the back side of the gland plate because of the limited axial space.

6.1.2.19 All piping or tubing connections shall be suitable for the hydrostatic test pressure of the seal chamber or gland plate to which they are attached.

6.1.2.20 Gland plates and/or seal chambers for contacting wet seals including the barrier or buffer chamber, and containment seal chambers shall be designed such that the seal chamber and piping system is self-venting during start-up and operation through the piping system. Designs, other than Piping Plan 23, requiring manual seal chamber venting shall be approved by the purchaser. The following shall apply.

- a) On small horizontal pumps where the elevation of the discharge nozzle is not high enough to achieve a continuously rising Piping Plan 11 flush line, then the connection may be located in the process piping upstream of the check valve if approved by the purchaser.
- b) The seal chamber or gland plate shall have a port no less than 3 mm ($1/8$ in.) above the seal faces to allow the removal of trapped gas if contacting wet seal arrangements are vertically oriented. This port shall be uppermost in the chamber (see Figure 17). This applies to ports for both sets of faces in Arrangement 2 (2CW-CW configuration) and the outer seal face of Arrangement 3 contacting wet seals when they are vertically oriented.
- c) Horizontal or vertical pumps having a Piping Plan 23 or vertical pumps having Piping Plans 11, 21, 31, and 41 shall be provided with a separate vent connection in the piping. Vertical pumps having Piping Plan 02 shall have a vent connection in the gland plate. Designs, other than these, requiring manual seal chamber venting require purchaser's approval.
- d) Low-volume seal flush systems that have positive flow due to differential pressures within the pump may not require manual venting (i.e. a short Piping Plan 11 or Piping Plan 13 on a small pump). Entrained gas will quickly purge from the piping and seal chamber upon start-up of the pump.

Table 2—Symbols and Size for Seal Chamber and Gland Plate Connections

Seal Config.	Symbol	Connection	Location	Type	Size ^a		Connection Required ^f
					Cat. 1	Cat. 2 and Cat. 3	
1CW-FX 1CW-FL	F	Flush	0	process	1/2 ^c	1/2	required
	FI	flush in (Plan 14 & 23 only)	180	process	1/2 ^c	1/2	WS
	FO	flush out (Plan 14 & 23 only)	0	process	1/2 ^c	1/2	WS
	D	drain	180	atmospheric	3/8 ^e	3/8	required
	Q	quench	90	atmospheric	3/8 ^e	3/8	required
	H	heating	—	utility	1/2 ^c	1/2	WS
	C	cooling	—	utility	1/2 ^c	1/2	WS
PIT	pressure sensing port	90	instrumentation	3/8	3/8	WS ^g	
2CW-CW	F	flush (inner seal)	0	process	1/2 ^c	1/2	required
	LBI	liquid buffer fluid in	180	process	1/2 ^d	1/2 ^d	required
	LBO	liquid buffer fluid out	0	process	1/2 ^d	1/2 ^d	required
	D	drain (outer seal)	180	atmospheric ^b	3/8 ^e	3/8	WS
	Q	quench (outer seal)	90	atmospheric ^b	3/8 ^e	3/8	WS
2CW-CS	F	flush (inner seal)	0	process	1/2	1/2	required
	FI	flush in (Plan 23 only)	180	process	1/2 ^c	1/2	WS
	FO	flush out (Plan 23 only)	0	process	1/2 ^c	1/2	WS
	GBI	gas buffer fluid in	90	process	1/4	1/4	WS
	CSV	containment seal vent	0	process	1/2	1/2	required
	CSD	containment seal drain	180	process	1/2	1/2	required
	D	drain (outer seal)	180	atmospheric ^b	3/8 ^e	3/8	WS
	Q	quench (outer seal)	90	atmospheric ^b	3/8 ^e	3/8	WS
2NC-CS	GBI	gas buffer fluid in	90	process	1/4	1/4	WS
	CSV	containment seal vent	0	process	1/2	1/2	required
	CSD	containment seal drain	180	process	1/2	1/2	required
	D	drain (outer seal)	180	atmospheric ^b	3/8 ^e	3/8	WS
	Q	quench (outer seal)	90	atmospheric ^b	3/8 ^e	3/8	WS
3CW-FB 3CW-FF 3CW-BB	F	flush (seal chamber)	0	process	1/2	1/2	WS
	LBI	liquid barrier fluid in	180	barrier	1/2 ^d	1/2 ^d	required
	LBO	liquid barrier fluid out	0	barrier	1/2 ^d	1/2 ^d	required
	D	drain (outer seal)	180	atmospheric ^b	3/8 ^e	3/8	WS
	Q	quench (outer seal)	90	atmospheric ^b	3/8 ^e	3/8	WS
3NC-FF 3NC-BB 3NC-FB	F	flush (seal chamber)	0	process	1/2	1/2	WS
	GBI	gas barrier fluid in	0	barrier	1/4	1/4	required
	GBO	gas barrier fluid out	180	barrier	1/2	1/2	WS
	D	drain (outer seal)	180	atmospheric ^b	3/8 ^e	3/8	WS
	Q	quench (outer seal)	90	atmospheric ^b	3/8 ^e	3/8	WS
	V	process vent	0	process	1/2	1/2	WS

^a All sizes listed in this table are NPT tapered thread connections.

^b These connections are rarely provided because they are only required when a throttle bushing is provided. A throttle bushing is not provided with standard Arrangement 2 and 3 configurations.

^c A 3/8 NPT connection may be used if 1/2 NPT is not possible because of space constraints.

^d 1/2 NPT required for shaft diameters 60 mm (2.5 in.) or smaller, 3/4 NPT for larger shaft sizes.

^e A 1/4 NPT connection may be used if 3/8 NPT is not possible because of space constraints.

^f WS = Connection is provided only when the appropriate piping plan is specified.

^g PIT port for indicating pressure transmitter required for Piping Plan 66A and Piping Plan 66B.

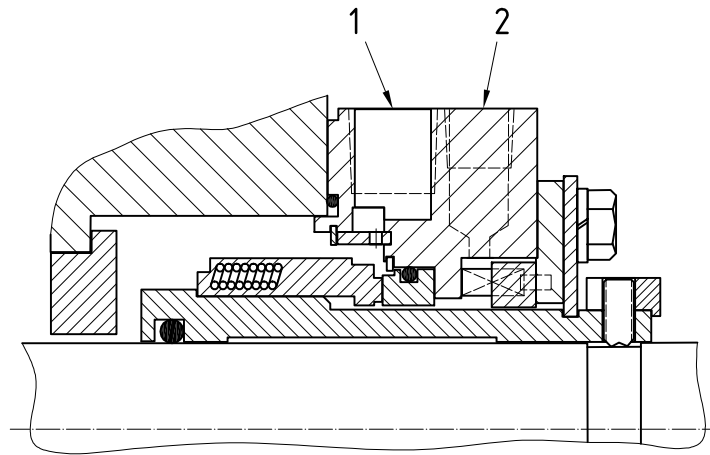
**Key**

- 1 process side
- 2 atmospheric side

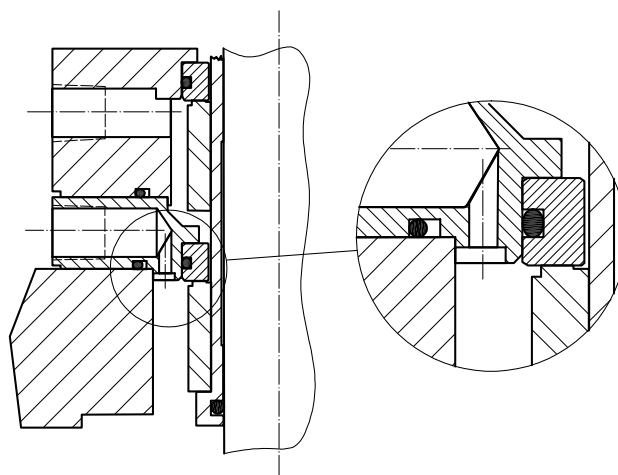
Figure 15—Mechanical Seal Piping Connections**Figure 16—Plastic Plug with Center Tab and Example of Warning Tag****Figure 17—Seal Chamber/Gland Plate for Vertical Pumps**

- e) Venting of the seal chamber for Arrangement 3 noncontacting seals prior to start-up and during operation may be necessary to avoid the collection of gas in the pump.

NOTE Drilling of throat bushing wall at top dead center, for horizontal shaft pumps, will allow natural venting of the seal chamber inside the pump. This can be a practical alternative when venting through the piping is either impractical or not possible.

6.1.2.21 Drilled passages shall be sized for the application and shall have a minimum diameter of 5 mm (³/₁₆ in.).

6.1.2.22 The diametrical clearance at a fixed throttle bushing bore shall not be more than specified in Table 1.

6.1.2.23 Floating throttle bushings made of carbon shall have a sleeve clearance as shown in Table 1.

NOTE If the bushing is designed to have the maximum diametrical clearance at a given pumping temperature, but the operation is below this temperature, the clearance will be greater than the one indicated in Table 1. If the purchaser wishes to minimize the clearance over a range of operating conditions, and therefore leakage past the bushing, consult the seal manufacturer for recommendation on material or a restriction device such as a segmented floating carbon bushing that can maintain a given clearance over a range of temperatures.

- **6.1.2.24** If specified, heating jackets or inserts shall be provided on seal chambers. Heating requirements shall be agreed between the purchaser, vendor and seal manufacturer.

NOTE The jacket can be used for temperature control, and this includes cooling as well as heating. Use of the jacket for cooling purposes is not recommended because of the relative inefficiency of the method and the tendency of plugging and fouling. Steam has been used effectively for cooling purposes on hot pumps and can prevent solidification of the process medium when idle. When a jacket is used, caution shall be exercised if skim cutting of the seal chamber bore is done, to insure that minimum wall thickness is maintained.

- **6.1.2.25** The supply of connections shall satisfy the requirements in 5.1. The lack of space for tap and port connections off the gland plate may require that these be included within the pump manufacturer's scope of supply, if approved by the purchaser.

6.1.2.26 All mating joints between the seal gland plate, the seal chamber, the containment seal chamber and the pump case shall incorporate a confined gasket to prevent blowout (see Figure 18). Controlled compression of the gasket (e.g. an O-ring or a spiral-wound gasket) shall be accomplished with metal-to-metal contact between the gland plate and the seal chamber face. The design of the joint shall prevent extrusion of the gasket to the interior of the seal chamber where it might interfere with seal cooling. Where space or design limitations make this requirement impractical, an alternative seal gland plate design shall be submitted to the purchaser for approval.

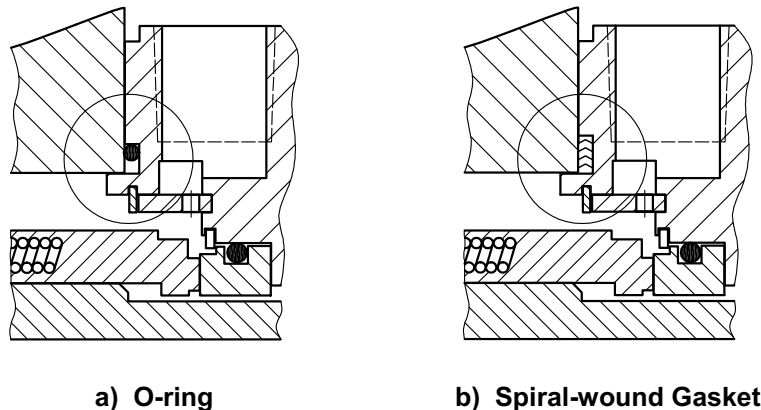

Figure 18—Mating Joint Gasket

NOTE To minimize runout, metal-to-metal contact is needed to keep faces and the shaft perpendicular for seals with rotating flexible elements.

6.1.3 Cartridge Seal Sleeves

6.1.3.1 Seal sleeves shall be furnished by the seal manufacturer. The sleeve shall be made of one piece and sealed at one end. (See 6.1.3.10 concerning auxiliary sleeves.) The seal sleeve assembly shall extend beyond the outer face of the seal gland plate.

NOTE Leakage between the shaft and the sleeve cannot be confused with leakage through the mechanical seal.

6.1.3.2 The seal manufacturer shall obtain the shaft diameter and tolerance from the pump manufacturer and ensure a shaft-to-sleeve fit of F7/h6 in accordance with ISO 286-2. This correlates to a clearance of 0.020 mm (0.0008 in.) to 0.093 mm (0.0037 in.) for the range of seal sizes covered by this standard, and varies as a function of diameter. The intent is to minimize sleeve runout (see Figure 19), while allowing for ease of assembly/disassembly. Shrink disks typically require tighter clearances and should follow the shrink-disk manufacturer's design criteria (see Figure 21).

API 610 requires a shaft diameter tolerance of h6; however, special cases may exist in which pumps are supplied with shaft diameter tolerances outside this. In such cases, the seal manufacturer shall ensure an appropriate fit.

NOTE Other methods to achieve the same level of concentricity are available. The purchaser may wish to discuss these alternatives with the pump and seal vendor.

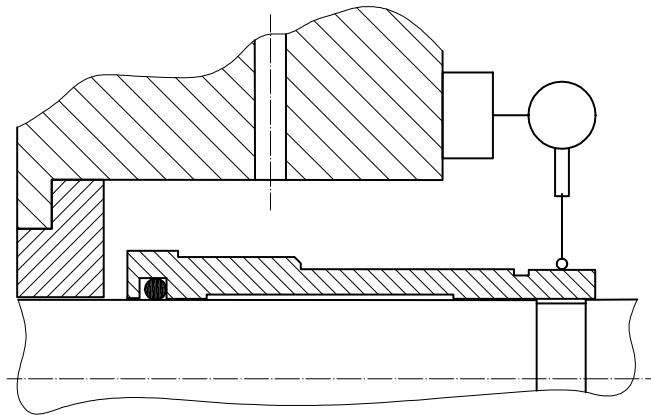

Figure 19—Seal Sleeve Runout

6.1.3.3 A clear means of guidance for setting the proper axial positioning of rotating elements on sleeves shall be provided.

NOTE This provision is intended to help the assembler of the seal properly locate seal components axially so that the correct spring load is attained. Features such as shoulders, or holes to receive dog points or pins, are examples of such clear means. This minimizes the possibility of error during assembly due to imprecise measurements or similar mistake. The intent is not to limit the seal designer to only one method.

6.1.3.4 Unless otherwise specified, shaft-to-sleeve sealing devices shall be elastomeric O-rings or flexible graphite rings. Metallic sealing devices are often unreliable, damage the shaft, and make disassembly difficult. Sealing devices should be softer than the shaft.

6.1.3.5 Shaft-to-sleeve O-ring seals shall be located at the impeller end of the sleeve. For shafts that require the O-ring to pass over the threads, at least 1.6 mm ($1/16$ in.) radial clearance shall be provided

between the threads and the internal diameter of the O-ring, and the diameter transition shall be radiused or chamfered (see 6.1.1.9) to avoid damage to the O-ring.

NOTE This location prevents pumpage from accumulating under the sleeve and making disassembly difficult.

6.1.3.6 Shaft-to-sleeve sealing devices located at the outboard end of the sleeve shall be captured between the sleeve and the shaft.

NOTE Flexible graphite is commonly used on metal bellows seals located on the outboard end of the sleeve.

6.1.3.7 Sleeves shall have a minimum radial thickness of 2.5 mm (0.10 in.) at their thinnest section, excluding a groove on the outer diameter of the sleeve to accommodate a seal-setting plate external to the gland plate.

The sleeve thickness in the area of component drive set screws shall be in accordance with Table 3. Using these dimensions dimples on the outside diameter of the sleeve to accommodate component drive set screws shall be no more than 0.50 mm (0.020 in.) deep.

NOTE 1 The sleeve thickness in the proximity of set-screw locations prevents sleeve distortion due to tightening of the set screws.

NOTE 2 Excessively thin sleeves distort easily.

6.1.3.8 The sleeve shall be machined and finished throughout its length such that the bore and outside diameter are concentric within 25 μm (0.001 in.) TIR.

Table 3—Minimum Sleeve Thickness in the Area of Component-drive Set Screws

Shaft Diameter		Minimum Sleeve Radial Thickness	
mm	(in.)	mm	(in.)
<57	(<2.250)	2.5	(0.100)
57 to 80	(2.250 to 3.250)	3.8	(0.150)
>80	(>3.250)	5.0	(0.200)

6.1.3.9 Sleeves shall be relieved along their bore, leaving a locating fit at or near each end.

NOTE Relieving the bore makes assembly and disassembly easier with the required close fits.

6.1.3.10 Where possible seal sleeves shall be designed as one piece. Cartridge designs for Arrangement 2 and 3 seals that incorporate an auxiliary sleeve to facilitate the assembly of the inner or outer seal components are acceptable. The auxiliary sleeve shall be axially located on the seal sleeve by positive means as specified in 6.1.3.3. Auxiliary sleeves shall be mounted concentrically to the sleeve and shall not extend beyond the sleeve. (See Figure 20 for an illustration of an auxiliary sleeve.)

6.1.3.11 Drive-collar set screws shall not pass through clearance holes unless the sleeve bore is relieved. For between-bearing pumps, the shaft shall be relieved in this area. This relieved area should be chamfered appropriately to avoid O-ring damage during seal installation.

NOTE If set screws are tightened against the shaft, the holes upset the metal on the shaft surface. If this damage is under the sleeve, it cannot be corrected prior to sleeve removal. For between-bearing pumps, the full length of the sleeve will then need to be pulled over the damaged area. This can cause the sleeve to gall to the shaft or otherwise be damaged. The problem is less severe with overhung pumps where only a small length of the sleeve needs to be pulled over the damaged area.

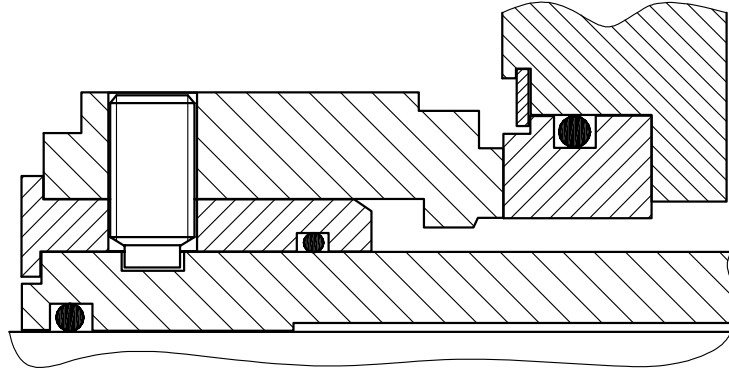

Figure 20—Auxiliary Sleeve Arrangement

6.1.3.12 Drive-collar set screws shall be of sufficient hardness to securely embed in the shaft. Unless otherwise specified the design shall be suitable for a maximum shaft hardness of 38 HRC (353HB). The pump and seal vendor shall ensure that adequate relative hardness exists between the pump shaft and the drive-collar set screws. See F.3.

6.1.3.13 It is the responsibility of the seal vendor to ensure that the drive-collar set screws shall be of sufficient number and size to ensure that rotational drive and axial positioning are adequate for the service conditions. For purposes of determining what is adequate the collar and set screw arrangement shall be able to statically maintain axial positioning under the axial load generated by a minimum of 150 % of the maximum pressure rating of the seal category according to 4.1.2. The axial load is calculated by multiplying the pressure by the annular surface area defined by the shaft and the seal balance diameter. See F.3 for calculation details.

6.1.3.14 Designs using nine or more set screws to drive and/or axially position the sleeve require purchaser approval.

The use of spot drilling on shafts for overhung pumps is not recommended, as this creates a stress riser that can reduce the fatigue life of the shaft.

Spot drilling should be done only after the axial position of the shaft is set. Ensure holes are drilled in line with the set screw holes on the drive collar so that no distortion of the collar or sleeve occurs when the set screws are tightened.

NOTE 1 As shaft size and sealing pressure increase, the axial force on the sleeve (pressure multiplied by area) increases. As the number of set screws increases, the drive collar is weakened and the amount of additional force each set screw will resist decreases.

NOTE 2 Dimples drilled in the pump shaft to accommodate set screws will result in a protruding lip around the drilled hole unless it is chamfered or otherwise eliminated. This lip will damage flexible graphite secondary seals and could damage O-rings.

NOTE 3 It may not be possible to use preexisting spot drilling for replacement seals.

NOTE 4 A shaft recess can aid in maintaining the axial location of the seal while lessening the possibility of shaft seal damage during installation.

- **6.1.3.15** If specified, or if recommended by the seal or pump manufacturer and approved by the purchaser, devices other than set screws may be used for axially positioning and driving the sleeve. Examples include a shrink disk (see Figure 21) or a split ring engaging a groove in the shaft (see Figure 22).

NOTE These designs are expensive and are usually used only on unspared pumps. Use of these designs avoids shaft damage by dimpling the shaft for dog-point set screws when high thrust loads exist on the sleeve.

6.1.4 Mating Rings

6.1.4.1 Antirotation devices shall be designed to minimize distortion of the seal faces. Clamped faces shall not be used unless approved by the purchaser (see Figure 23).

NOTE Flat seal faces are essential for achieving low emissions and good seal performance. Clamped rings are easily distorted.

6.1.4.2 The arrangement of the mating ring and its mounting into the seal gland plate shall be designed to facilitate cooling of the ring and to avoid thermal distortion.

NOTE Mating rings that are mounted deep in the gland plate and have minimal contact with the process fluid tend to not transfer heat away effectively. The resulting temperature gradients can cause distortion of the faces.

6.1.5 Flexible Elements

- **6.1.5.1** If specified by the purchaser and agreed by the vendor, a single-spring Type A seal shall be furnished.

NOTE 1 Multiple coil-spring seals tend to be more axially compact than single coil-spring seals. This gives wider applicability when dual seals are considered. Multiple springs also tend to provide more even loading.

NOTE 2 Single-spring seals generally add 6 mm (0.25 in.) to 13 mm (0.5 in.) to the axial space requirement of a sealing application. For single seal applications, the single spring has advantages and disadvantages. The single spring allows a lower spring rate to achieve the same face loading. This makes the single spring more tolerant of axial misalignment resulting from changes in the relative axial location of the shaft with respect to the seal chamber (such as in case of differential thermal expansion.) The use of cartridge seals has largely eliminated errors in axial setting of the seal.

NOTE 3 For corrosive services, the wire in single springs is significantly greater in cross-section, providing a greater corrosion allowance. Multiple springs can more easily be located outside the process, thus eliminating immersion of the spring in the corrosive media.

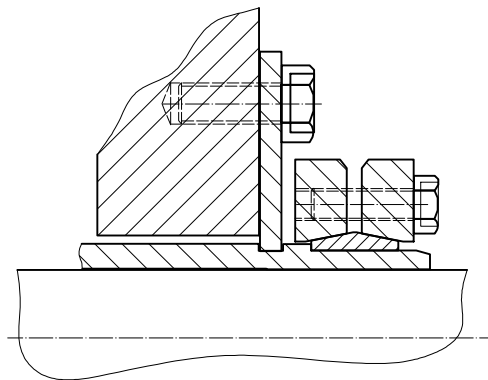

Figure 21—Seal Sleeve Attachment by Shrink Disk

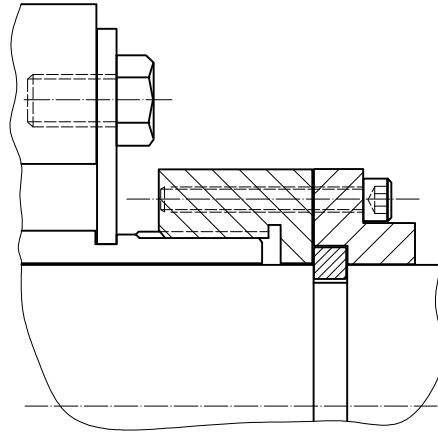

Figure 22—Seal Sleeve Attachment by Split Ring

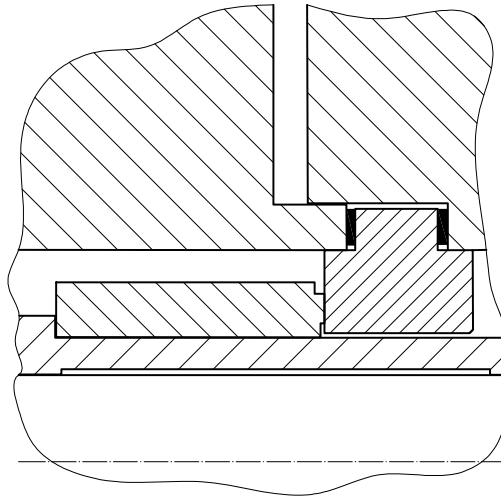

Figure 23—Clamped Faces

6.1.5.2 Flexible elements shall not rely on static lapped joints for sealing.

This requirement means that designs such as lapped-joint rotating seal rings are prohibited, as they employ an unretained slip fit into a flexible element unit. Designs retaining the seal ring with an interference fit and/or gasket are acceptable.

6.1.6 Materials

6.1.6.1 General

6.1.6.1.1 Unless otherwise specified on the datasheets, seal components shall be furnished with the materials referenced in 6.1.6.2 to 6.1.6.9.

NOTE 1 Proper material selection is critical to the reliable operation of a mechanical seal. Selection depends on the characteristics of the contacting fluid. Variables such as operating temperature, pressure, speed, lubricity, and chemical compatibility are key parameters. The purchaser should solicit seal manufacturer input when in doubt about the compatibility of these materials with the intended service. See *NACE Corrosion Engineer's Reference Book* for one source of suitable materials.

NOTE 2 Material selection can vary depending on the function of the part and its proximity to, or contact with, the process fluid. Thus, it is not uncommon in corrosive services for dual seals to have different material used for components in the outer part of the seal that are not wetted by the process fluid.

6.1.6.1.2 Superior or alternative materials recommended for the service by the seal manufacturer shall be stated in the proposal.

6.1.6.1.3 Materials identified in the proposal other than those specified in this standard, or materials for an engineered seal, or exceptions to materials in this standard, shall be identified with their applicable specification numbers (e.g. ISO, EN, ASTM, etc.) and the material grade. If no such designation exists, the manufacturer's material specification, giving physical properties, chemical composition, and test requirements, shall be made available upon request.

6.1.6.2 Seal Faces

6.1.6.2.1 Each seal shall be comprised of a seal ring and a mating ring.

NOTE 1 This standard does not apply to split mechanical seals where ring segments are used.

NOTE 2 The following are general guidelines. There are many face material available, each having relative benefits and disadvantages. Consult the seal manufacturer for the best face combination in a particular service. No material or material combination is excluded simply from the fact that it is not specifically mentioned, but in order to fall within the scope of this standard the material or combination shall pass the relevant qualification testing.

6.1.6.2.2 Except as required by 6.1.6.2.4, one of the rings shall be premium grade, blister-resistant carbon graphite, with manufacturing treatment to reduce wear, provide chemical resistance, and minimize porosity consistent with the intended service.

- **6.1.6.2.3** For all seal categories the material for one of the rings shall be reaction-bonded silicon carbide (RBSiC) or self-sintered silicon carbide (SSSiC), depending on the chemical compatibility and recommendation by the seal vendor. Several grades of these materials are available; therefore, the manufacturer shall state the type of silicon carbide offered for each service.

NOTE See B.2.3 for guidance related to manufacture and use of RBSiC versus SSSiC.

6.1.6.2.4 Abrasive, viscous, and high-pressure services may require two hard materials. For such services, unless otherwise specified, the default material for both the seal ring and the mating rings shall be silicon carbide. Other hard face combinations of SSSiC, RBSiC, and graphite loaded SSSiC, graphite loaded RBSiC, or tungsten carbide are widely used and are acceptable with purchaser approval.

NOTE See B.2.4 for guidance regarding the selection of optimum hard face-material combinations.

6.1.6.2.5 Seal and mating rings shall be of homogeneous material, except that inherently wear-resistant materials such as silicon carbide or tungsten carbide may be enhanced by applying a coating. Overlays or coatings shall not be used as the sole means of providing wear resistance.

NOTE Temperature limitations for seal-face materials are listed in B.2.

6.1.6.2.6 The seal manufacturer shall advise if the specified face material combination may not be suitable for performance testing of the pump on water. If so, the seal manufacturer shall recommend alternative materials for use during pump performance testing.

6.1.6.3 Seal Sleeves

Unless otherwise specified, seal sleeves shall be stainless steel [Austenitic Stainless Steel Type 316, 316L, or 316Ti, or equivalent (see B.1)]. Sleeves for alloy pumps in corrosive services shall be of the same alloy as the casing, or one with superior corrosion resistance.

6.1.6.4 Springs

Unless otherwise specified, seals with multiple coil-springs shall be Alloy C-276 or Alloy C4 spring material. Single coil-springs shall be Austenitic Stainless Steel Type 316 stainless steel spring material.

NOTE Cross-section thickness of the spring is taken into consideration when selecting spring materials. Heavier cross-section springs, such as those found in single-spring seals, are not as prone to stress corrosion cracking as the thinner cross-section type found in multiple-spring seals. For example, Alloy C-276 is the material most suited to multiple-spring seals, whereas Austenitic Stainless Steel Type 316 stainless steel may be just as suitable in the same service using a single spring.

6.1.6.5 Secondary Seals

6.1.6.5.1 Unless otherwise specified, O-rings shall be FKM. Temperature limitations for elastomers are listed in B.3.

6.1.6.5.2 Unless otherwise specified, if operating temperatures or chemical compatibility preclude the use of FKMs, O-rings shall be FFKMs. See B.3 for additional details.

6.1.6.5.3 Seal manufacturers shall use secondary seals from vendors having experience equal to at least two installations in operation in similar service for at least one year in the refining, chemical, or pipeline industry and shall use material types and grades selections based on successful prior use in the refining, chemical, or pipeline industry. One vendor/material grade/type/durometer shall be used in the qualification test. Similar grades, types with the same nominal durometer in the dynamic secondary seal location (with a tolerance range of ± 5 Shore A hardness) from other vendors may be substituted in the commercial product without additional qualification testing specified in Annex I.

6.1.6.5.4 Unless otherwise specified, if the temperature or chemical limitations of elastomers have been exceeded, secondary seals shall be flexible graphite.

6.1.6.6 Metal Bellows

Unless otherwise specified, metal bellows shall be Alloy C-276 for Type B seals and Alloy 718 for Type C seals. If recommended by the seal vendor and agreed to by the purchaser, Alloy 718 may also be used for Type B seals.

6.1.6.7 Gland Plates

6.1.6.7.1 Unless otherwise specified, gland plates shall be stainless steel [Austenitic Stainless Steel Type 316, 316L, or 316Ti, or equivalent (see B.1)]. Gland plates for alloy pumps in corrosive services shall be of the same alloy as the casing, or one with superior corrosion resistance.

- **6.1.6.7.2** Unless otherwise specified, the gland plate to seal chamber gasket shall be an O-ring for services below 175 °C (350 °F) of the same material required by 6.1.6.5.1 and 6.1.6.5.2. For temperatures over 175 °C (350 °F) or if specified, graphite-filled type Austenitic Stainless Steel Type 304 or Austenitic Stainless Steel Type 316 stainless steel spiral-wound gaskets shall be used.

NOTE Spiral-wound gaskets have bolt torque requirements for full compression. See 6.1.2.7 for bolting requirements for spiral-wound gaskets.

6.1.6.7.3 Nameplates and rotation arrows (if attached) shall be of austenitic stainless steel or nickel-copper (UNS N04400) alloy. Stamp top of seal gland with rotation arrow for between bearing pumps that have unidirectional seals. Attachment pins shall be of the same material. Welding shall not be permitted.

6.1.6.8 Bolt-on Seal Chambers

6.1.6.8.1 Bolt-on seal chambers for alloy pumps shall be of the same alloy as the casing, or one with superior corrosion resistance and mechanical properties. Unless otherwise specified, seal chambers for other pumps shall be stainless steel [Austenitic Stainless Steel Type 316, 316L, or 316Ti, or equivalent (see B.1)].

The user should consider thermal expansion properties of the materials to avoid stress or gasket-related problems if bolt-on chambers are supplied for high-temperature services in material dissimilar to that of the pump or attachment stud.

6.1.6.8.2 Chamber-to-casing gasket material requirements shall conform to 6.1.6.7.2.

6.1.6.9 Miscellaneous Parts

6.1.6.9.1 Unless otherwise specified, spring-retaining components, drive pins, antirotation pins, and internal set screws shall have strength and corrosion resistance equal to or better than AISI Type 316 stainless steel (see B.1).

6.1.6.9.2 The pump and seal vendors shall ensure that outside drive components have suitable corrosion resistance for the service (see F.3). If used, set screws shall have sufficient hardness and design to carry the load. Alternative methods may be used, such as spot drilling, split rings, or shrink disks. See also 6.1.3.12 and 6.1.3.13.

If hardened carbon steel set screws are not suitable for the service, then a hardened stainless steel set screw should be provided.

6.1.6.10 Welding

6.1.6.10.1 Welding of piping, pressure-containing parts, rotating parts, and other highly stressed parts, weld repairs and any dissimilar metal welds shall be performed and inspected by operators and procedures qualified in accordance with the appropriate part of EN 287 and EN 288, or ASME IX. Metal bellows used are exempted from this requirement because they are manufactured using a proprietary welding process that is not covered by general welding codes or industry standards.

6.1.6.10.2 The manufacturer shall be responsible for the review of all repairs and repair welds to ensure that they are properly heat treated and nondestructively examined for soundness and compliance with the applicable qualified procedures. Repair welds shall be nondestructively tested by the same method used to detect the original flaw. As a minimum, the inspection shall be by liquid penetrant for stainless steel components and magnetic particle for ferrous materials.

6.1.6.10.3 Unless otherwise specified, non-pressure-retaining structural welding, such as welding on baseplates, nonpressure ducting, lagging, and control panels, shall be performed in accordance with AWS D1.1.

6.1.6.10.4 Pressure casings made of wrought materials or combinations of wrought and cast materials shall conform to the conditions specified in Items a), b), c), and d) below. This includes bolt-on seal chambers if constructed by welding.

- a) Plate edges shall be inspected by magnetic particle or liquid penetrant examination as required by ASME VIII, Division 1, UG-93(d)(3).
- b) Accessible surfaces of welds shall be inspected by magnetic particle or liquid penetrant examination after back-chipping or gouging and again after postweld heat treatment.
- c) Pressure-containing welds, including welds of the case to horizontal and vertical joint flanges, shall be full-penetration welds.

d) Fabricated pressure-retaining parts (regardless of thickness) shall be postweld heat-treated.

6.1.6.10.5 Connections welded to the pressure-retaining parts shall be installed as follows.

- a) 100 % radiography, magnetic particle examination, ultrasonic examination, or liquid penetrant examination of welds shall be performed, if specified and in addition to 6.1.6.10.1.
- b) Auxiliary piping welded to alloy steel pressure-retaining parts shall be of a material with the same nominal properties as the casing material or shall be of low-carbon austenitic stainless steel. Other materials compatible with the casing material and intended service may be used with the purchaser's approval. If heat treatment is required, piping welds shall be made before the component is heat treated.
- c) Proposed connection designs shall be submitted to the purchaser for approval before fabrication, if specified. The drawings shall show weld designs, size, materials, and pre-weld and postweld heat treatments.
- d) All welds shall be heat treated in accordance with the methods described in EN 13445 or ASME VIII, Division 1, UW-40.

6.1.6.11 Low Temperature Service

- **6.1.6.11.1** For operating temperatures below $-30\text{ }^{\circ}\text{C}$ ($-20\text{ }^{\circ}\text{F}$) or, if specified, for other low ambient temperatures, steels shall have properties as described in 6.1.6.11.2 to 6.1.6.11.6.

NOTE Also see B.3, which covers temperature limits for elastomers.

6.1.6.11.2 To avoid brittle failures, materials of construction for low-temperature service shall be suitable for the minimum design metal temperature in accordance with the codes and other requirements specified. The purchaser and the vendor shall agree on any special precautions necessary with regard to conditions that may occur during operation, maintenance, transportation, erection, commissioning, and testing.

Good design practice should be followed in the selection of fabrication methods, welding procedures, and materials for vendor-furnished steel pressure-retaining parts that may be subject to temperatures below the ductile-brittle transition temperature. The published design-allowable stresses for metallic materials in standards such as the ASME *Boiler and Pressure Vessel Code* are based on minimum tensile properties. Some standards do not differentiate between rimmed, semi-killed, fully-killed hot-rolled and normalized material, nor do they take into account whether materials were produced under fine- or course-grain practices. The vendor should exercise caution in the selection of materials intended for services between $-30\text{ }^{\circ}\text{C}$ ($-20\text{ }^{\circ}\text{F}$) and $40\text{ }^{\circ}\text{C}$ ($100\text{ }^{\circ}\text{F}$).

6.1.6.11.3 All pressure-retaining steels applied at a specified minimum design metal temperature below $-30\text{ }^{\circ}\text{C}$ ($-20\text{ }^{\circ}\text{F}$) require a Charpy V-notch impact test of the base metal and the weld joint unless they are exempt in accordance with ASME VIII, Division 1, UHA-51. Impact test results shall meet the requirements of ASME VIII, Division 1, UG-84.

6.1.6.11.4 Carbon and low alloy steel pressure-retaining parts applied at a specified minimum design metal temperature between $-30\text{ }^{\circ}\text{C}$ ($-20\text{ }^{\circ}\text{F}$) and $40\text{ }^{\circ}\text{C}$ ($100\text{ }^{\circ}\text{F}$) shall require impact testing, as follows.

- a) Impact testing is not required for parts with a governing thickness (see 6.1.6.11.5) of 25 mm (1 in.) or less.
- b) Impact testing exemptions for parts with a governing thickness (see 6.1.6.11.5) greater than 25 mm (1 in.) shall be established in accordance with ASME VIII, Division 1, UCS-66. The minimum design metal temperature without impact testing may be reduced as shown in ASME VIII, Division 1, Figure UCS-66.1. If the material is not exempt, Charpy V-notch impact test results shall meet the minimum impact energy requirements of ASME VIII, Division 1, UG-84.

6.1.6.11.5 The governing thickness used to determine impact-testing requirements shall be the greater of the following:

- a) the nominal thickness of the largest butt welded joint;
- b) the largest nominal section for pressure containment, excluding:
 - 1) structural support sections such as feet or lugs; and
 - 2) structural sections required for attachment or inclusion of mechanical features such as jackets or seal chambers.
- c) one-fourth of the nominal flange thickness, including gland plate and seal chamber flanges.

- **6.1.6.11.6** The purchaser shall specify the minimum design metal temperature to be used to establish impact test requirements.

NOTE Normally, this will be the minimum surrounding ambient temperature or minimum liquid pumping temperature, whichever is lower. However, the purchaser may specify a minimum design metal temperature based on pumpage properties, such as autorefrigeration at reduced pressures.

6.2 Design Requirements (Category-specific)

6.2.1 Category 1 Seals

6.2.1.1 General Information (Category 1)

This subsection provides design details for Category 1 seals, as described in Section 4. Specific information provided here is in addition to the common seal design features listed in 6.1.

6.2.1.2 Seal Chamber and Gland Plate (Category 1)

- **6.2.1.2.1** If specified, or if required by 6.1.2.14, a distributed seal flush system such as a circumferential or multiport arrangement shall be provided for Arrangement 1 and Arrangement 2 seals. The seal flush arrangement shall be located to maximize the uniformity and degree of cooling of the seal faces. For multiport systems, ports having a minimum diameter of 3 mm ($1/8$ in.) shall be used.

6.2.1.2.2 The seal flush passages shall be designed so that they can be cleaned (see Figure 24).

NOTE In many cases, effective seal operation is dependent on distributed flush systems that maximize heat removal from the seal faces to ensure effective film formation and prevent asymmetrical thermal distortions in sealing components. There are other methods for distributing the flush in addition to those illustrated in Figure 24. Depending on face orientation and space available on some seal designs a distributed flush system as shown in Figure 24 may not be required for Arrangement 2 seals because this may become unnecessarily complex and expensive. In these circumstances, consult the seal manufacturer for detailed information on the features and benefits of variations to the flush distribution systems to achieve even cooling around the circumference of the face components.

6.2.2 Category 2 Seals

6.2.2.1 General Information (Category 2)

This subsection provides design details for Category 2 seals, as described in Section 4. Specific information provided here is in addition to the common seal design features listed in 6.1.

6.2.2.2 Seal Chamber and Gland Plate (Category 2)

6.2.2.2.1 A distributed flush system shall be provided for Category 2, Arrangement 1 and Arrangement 2 seals except when Piping Plan 13 and Piping Plan 23 are specified. The seal flush arrangement shall be

located to maximize the uniformity and degree of cooling of the seal faces. For multiport systems, ports having a minimum diameter of 3 mm ($1/8$ in.) shall be used.

6.2.2.2.2 The seal flush passages shall be designed so that they can be cleaned (see Figure 24).

NOTE See NOTE in 6.2.1.2.2.

6.2.2.3 Cartridge Seal Sleeves (Category 2)

6.2.2.3.1 Standard seal sizes shall fit shafts in even 10 mm increments.

6.2.2.3.2 If key drives are supplied, keys shall be positively secured to the shaft (see Figure 25).

NOTE Keys located on the shaft deep in traditional stuffing boxes cannot be easily reached for seal assembly.

6.2.3 Category 3 Seals

6.2.3.1 General Information (Category 3)

This subsection provides design details for Category 3 seals, as described in Section 4. Specific information provided here is in addition to the common seal design features listed in 6.1. Category 2 information from 6.2.2 applies to Category 3 seals, except as amended in this subsection.

6.2.3.2 Seal Chamber and Gland Plate (Category 3)

6.2.3.2.1 A distributed flush system shall be provided for Category 3, Arrangement 1 and Arrangement 2 seals except when Piping Plan 13 and Piping Plan 23 are specified. The seal piping arrangement shall be located to maximize the uniformity and degree of cooling of the seal faces. For multiport systems, ports having a minimum diameter of 3 mm ($1/8$ in.) shall be used.

6.2.3.2.2 The seal flush passages shall be designed so that they can be cleaned (see Figure 24).

NOTE See NOTE in 6.2.1.2.2.

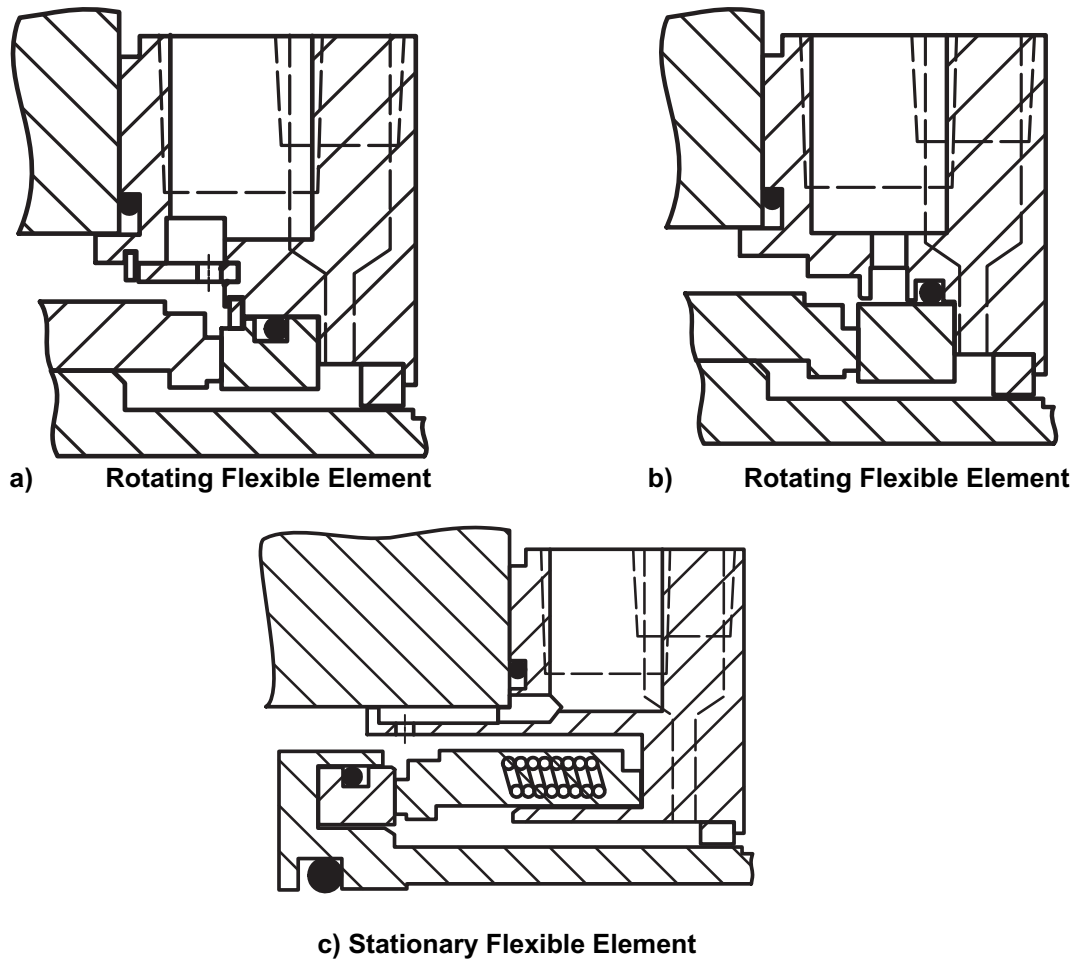

These are only examples—other configurations may be used.

Figure 24—Distributed Flush Systems

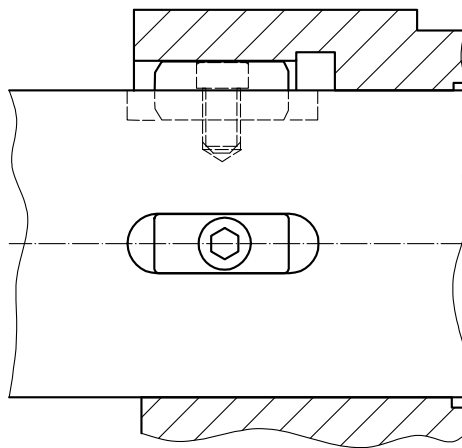

Figure 25—Attachment of Key Drives to Shaft

7 Specific Seal Configurations

7.1 Arrangement 1 Seals

7.1.1 Seal Sleeves

Seal sleeves shall be in one piece.

7.1.2 Seal Chamber and Gland Plate

7.1.2.1 Unless otherwise specified:

- a) fixed throttle bushing made of carbon shall be installed in the gland plate for Category 1 seals;
- b) close-clearance (floating) throttle bushing made of carbon shall be installed in the gland plate for Category 2 seals;
- c) close-clearance (floating) throttle bushing made of carbon shall be installed in the gland plate for Category 3 seals;
- d) segmented carbon bushing shall be an option for Category 2 and Category 3 seals as given in 6.1.2.24.

Throttle bushings shall be positively retained against pressure blowout to minimize leakage if the seal fails. Alternative leakage control devices may be provided as specified.

Bushings may be sized to allow for thermal growth of the shaft.

NOTE Carbon bushing material is suitable for chemical plant and refining services, but is more sensitive to impact damage than a spark resistant metal bushing. Category 2 seals are designed to fit into API 610 seal chambers and will be used in most refinery services. PTFE (and PTFE-graphite composites) is a less desirable bushing material because of its thermal expansion properties and lack of memory. Refer to B.4 and F.5.

- **7.1.2.2** If specified, a close-clearance (floating) throttle bushing made of carbon shall be furnished for Category 1 seals.

7.1.2.3 When Piping Plan 66A is specified, an inner segmented floating carbon bushing and an outer floating solid carbon bushing shall be used. If the distance between the seal gland face and the nearest obstruction is insufficient for an inner floating segmented carbon bushing, use Piping Plan 66B or consult the seal vendor for recommendations.

When Piping Plan 66B is specified a floating segmented carbon bushing shall be used. The drain port shall be plugged with an orifice plug as specified in 8.3.5.6. If the distance between the seal gland face and the nearest obstruction is insufficient for a floating segmented carbon bushing use a floating solid carbon bushing or consult the seal vendor for recommendations.

7.1.2.4 Unless otherwise specified, flush/vent, and drain connections shall be provided and plugged. Plugs for threaded connections shall comply with 6.1.2.18.

- **7.1.2.5** If specified, or if required by the seal manufacturer, an external quench (see Figure G.24) shall be provided to the seal gland plate in accordance with the following:
 - a) the design shall direct the quench to the seal face and secondary seals;
 - b) seals equipped with a water quench shall be designed to allow quench water to exit via the drain connection;

- c) if a steam quench is specified and if space allows, the seal gland plate shall be equipped with a quench baffle; and
- d) the baffle shall be nonsparking material designed not to contact adjacent relatively moving components due to distortion or heating.

NOTE 1 Quenching involves the introduction of a medium, usually water, nitrogen or steam, on the atmospheric side of a mechanical seal assembly. Quenching is normally applied if the material being sealed is noxious, flammable, oxidizes, polymerizes, or will crystallize when dried. Quenching can also be used for heating or cooling. The gland plate is equipped with a throttle bushing to prevent moisture or steam leakage from a quenched seal from entering the bearing housing and contaminating the lubricating oil, and to maximize containment of the quench fluid.

NOTE 2 This baffle directs the steam to the area where coke would tend to collect, and routes the steam to carry material away from the seal and seal faces. By cooling the leakage on the atmospheric side of the seal faces, a steam quench prevents coke formation and subsequent seal hang-up in hot [above 150 °C (300 °F)] services. It also keeps viscous product thin when the pump is not running. If stocks thicken at the faces, seals can be damaged at start-up. Condensation collecting at the seal faces can vaporize and damage the seal faces.

7.1.2.6 Unless otherwise specified, Type C, Arrangement 1 seals shall include a quench baffle. The quench baffle shall meet the requirements of 7.1.2.5 d).

7.1.2.7 Seal systems that utilize internal circulating devices, such as a pumping ring, and rely on the rotation of the mechanical seal to maintain circulation shall be designed with the inlet at the bottom of the seal and the outlet at the top of the seal as space allows.

NOTE This requirement enhances venting and thermosyphoning when the pump shaft is not rotating.

7.1.2.8 The internal circulating device shall provide the required flow rate using the specified flush/barrier/buffer fluid, at all operating and start-up conditions based upon the accessory components supplied and the maximum dimensional criteria in Figure G.17 and Figure G.18.

NOTE The internal circulating device needs to be very carefully checked for pump speeds that vary from those specified in the performance curves provided according to 7.1.2.9 and for pumps equipped with variable-speed drivers. Fluid properties such as viscosity will also affect flow rates, and these are often dependent on temperature conditions. Thus all transient as well as steady state conditions shall be taken into account. Refer to F.2 for detailed discussion of these factors.

- **7.1.2.9** For Category 3 or if specified, the seal manufacturer shall provide the performance curve for head versus flow for the internal circulating device based on actual qualification test results.

NOTE For conditions other than those encountered in the qualification test, calculated performance curves should be based on modeling and/or additional tests as needed.

7.1.2.10 The minimum diametral clearance between the rotating element of a circulation device and stationary component, seal chamber bore or containment chamber bore shall be in accordance with the values listed in Table 1.

7.1.2.11 Designs of mechanical seals utilizing internal circulating devices shall ensure that the device inlet and outlet ports properly align with the barrier/buffer fluid or seal-flush supply and return connections when installed in the seal chamber.

7.2 Arrangement 2 Seals

7.2.1 General

7.2.1.1 Unless otherwise specified, the inner seal shall be a contacting wet seal (2CW-CW, see Figure 3, or 2CW-CS, see Figure 4a) with a face to back configuration. The inner seal shall have an internal (reverse) balance feature designed and constructed to withstand reverse pressure differentials up to 0.275 MPa (2.75 bar) (40 psi) without opening or dislodging components. Refer to Figure 10.

NOTE 1 The containment seal chamber pressure is normally less than the inner seal chamber pressure. The containment seal chamber is usually connected through an orifice to a vapor recovery system, in which case it will operate at the pressure of the system to which it is connected. It is unusual for a vapor recovery system to reach a gauge pressure of 0.275 MPa (2.75 bar) (40 psi) even under upset conditions.

NOTE 2 The default face to back configuration is based on installed population, but there is no technical requirement for this configuration as the pressure on the outer seal is low. Other configurations are just as appropriate subject to the requirements of 4.2 b).

- **7.2.1.2** If specified a noncontacting inner seal (2NC-CS, see Figure 4b) shall be provided.

NOTE Noncontacting inner seal designs utilize a lift-off face pattern, such as grooves or waves, which can provide reliable operation in liquid or gas service. Often it is difficult to provide adequate vapor suppression margin when sealing clean high vapor pressure or mixed vapor pressure fluids with contacting wet-face designs. A noncontacting inner seal can give the option of sealing a liquid/gas mixture by allowing the product to flash into a gas across the seal faces, effectively using the noncontacting design inner seal as a gas seal. The leakage rate from a noncontacting design is normally higher than a contacting wet design.

7.2.1.3 Unless otherwise specified, a contacting wet seal shall be used with liquid buffer systems and a noncontacting containment seal shall be used if a liquid buffer system is not provided.

If recommended by the seal manufacturer and agreed by the purchaser, a contacting containment seal face design may be provided.

NOTE 1 Noncontacting containment seals utilize a face pattern (grooves, waves, etc.) to provide lift-off of the seal faces. Relative to contacting “dry-running” containment seals, noncontacting face designs:

- a) have a lower wear rate in operation;
- b) are more tolerant to a buffer gas environment with dew points below $-40\text{ }^{\circ}\text{C}$ ($-40\text{ }^{\circ}\text{F}$);
- c) are designed for higher surface speeds and pressure differentials; and
- d) may experience leakage rates an order of magnitude greater than that of contacting containment seals.

NOTE 2 Contacting containment seal designs normally provide the lowest leakage of vapors and liquids. Manufacturer’s standard dry contacting seal designs are pressure limited for continuous service, usually below a gauge pressure of 0.07 MPa (0.7 bar) (10 psi). However, designs are suitable in a gas environment of product vapors for continuous operation with excursions in gauge pressure to 0.275 MPa (2.75 bar) (40 psi) to allow for variation in the vapor recovery system pressure. Friction and rubbing wear is dependent on the shaft speed, containment seal chamber pressure, and properties of the vapor being sealed. Use of “bone-dry” nitrogen as a buffer gas can result in rapid carbon face wear. Refer to F.1 for further information.

- **7.2.1.4** If utilized, the buffer fluid shall be specified on the datasheet.

NOTE Many existing 2CW-CS installations do not use an external buffer gas. If a buffer gas is not used, the containment seal chamber is filled with vaporized process fluid.

7.2.2 Seal Chamber and Gland Plates

- **7.2.2.1** If specified and if additional length for the seal arrangement is available, a fixed throttle bushing made of carbon shall be installed in the gland plate and positively retained against pressure blowout.

NOTE 1 A throttle bushing is rarely required with a dual seal but may be used in cold services where a quench is used to avoid icing.

NOTE 2 Limited axial space between the seal chamber face and the bearing housing often makes the use of a throttle bushing with an Arrangement 2 seal impractical.

7.2.2.2 Seal systems that utilize internal circulating devices shall comply with the provisions of 7.1.2.7 through 7.1.2.11.

7.2.3 Contacting Wet Seals with a Liquid Buffer Fluid (2CW-CW)

7.2.3.1 Liquid buffer systems shall be designed such that the maximum temperature differential between the buffer fluid inlet and outlet immediately adjacent to the seal chamber is:

- 8 °C (15 °F) for glycol/water or buffer fluids with viscosity close to that of water and
- 16 °C (30 °F) for oil buffer fluids.

NOTE The allowable temperature differential includes the effects of both “heat soak” and seal-face-generated heat. The allowable temperature differential across the seal should not be confused with the bulk temperature rise of the buffer fluid during steady-state operation or with the differential temperature between the process fluid and steady-state buffer fluid temperature.

7.2.3.2 There are various ways to achieve enhanced flow in and out of the seal chamber such as tangential ports, internal dams or cutwaters, radial and axial flow rings, and modified seal chamber designs. The seal shall meet the temperature rise criteria, and the vendor qualification testing of Section 10. See 7.1.2.7 through 7.1.2.11 for requirements on internal circulating devices.

7.2.4 Seal Chamber and Gland Plates for Contacting Wet Inner Seal with a Dry-running Containment Seal (2CW-CS)

7.2.4.1 A fixed spark resistant bushing, or equivalent device approved by the purchaser, shall be installed to separate the containment-seal faces from the containment seal vent or drain connection ports. The bushing shall be positively retained to prevent axial movement and damage to seal components. The minimum diametral clearance between the bushing and rotating parts in the seal chamber shall be in accordance with Table 1 (see Figure 26).

Purchaser’s approval is required for any alternative seal chamber layout that deviates from the standard layout described above.

NOTE The bushing helps isolate the containment-seal faces from normal inner-seal leakage by directing it toward the containment-seal vent or drain connection. Space limitations might require the seal supplier to propose an alternative containment-seal chamber layout.

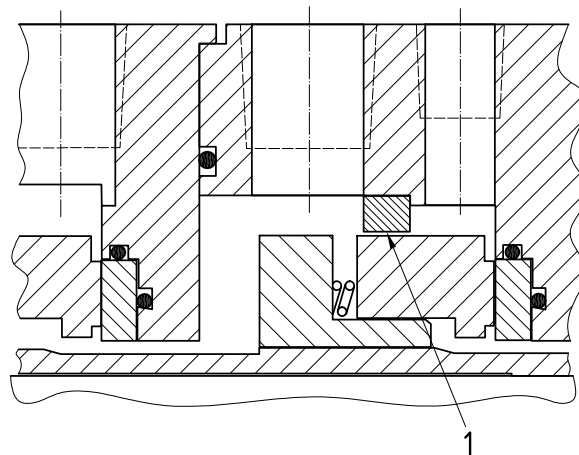

Key

- 1 containment-seal chamber bushing

Figure 26—Section Showing Containment-Seal Chamber Bushing for 2CW-CS and 2NC-CS Configurations

7.2.4.2 The use of the containment-seal vent or drain connections for buffer gas injection is permitted only with the purchaser's approval.

7.2.5 Seal Chamber and Gland Plates for Noncontacting Inner Seal with a Dry-running Containment Seal (2NC-CS)

7.2.5.1 A fixed spark resistant bushing, or equivalent device approved by the purchaser, shall be installed to separate the containment-seal faces from the containment vent and drain connection ports. The bushing shall be positively retained to prevent axial movement and damage to seal components. The minimum diametral clearance between the bushing and rotating parts in the seal chamber shall in accordance with Table 1 (see Figure 4b).

Purchaser's approval is required for any alternative seal chamber layout that deviates from the standard layout described above.

NOTE The bushing helps isolate the containment-seal faces from normal inner-seal leakage by directing it toward the containment-seal vent or drain connection. Space limitations might require the seal supplier to propose an alternative containment-seal chamber layout.

7.2.5.2 The use of the containment-seal vent or drain connections for buffer gas injection is permitted only with the purchaser's written approval.

7.3 Arrangement 3 Seals

7.3.1 General

- **7.3.1.1** The barrier fluid shall be a liquid or gas, as specified.

NOTE 1 Barrier fluid pressure is usually regulated between a gauge pressure of 0.14 MPa (1.4 bar) (20 psi) and 0.41 MPa (4.1 bar) (60 psi) over the pressure in the seal chamber.

NOTE 2 Gas-barrier seal designs might not be appropriate for services in which dissolved or suspended solids in the pumped fluid tend to adhere to the seal faces or cause hang-up. This is especially true if the process fluid is on the ID of the inner gas-lubricated seal. Liquid-barrier seal designs arranged such that the process fluid is on the OD of the seal faces help to minimize solids accumulation on the faces and minimize hang-up.

NOTE 3 While stationary, capillary action of sticky or polymerizing fluids between gas-barrier-lubricated faces can cause torque failure upon start-up, even if the gas-barrier pressure is maintained while the pump is idle.

7.3.1.2 Unless otherwise specified:

The inner seal shall have an internal (reverse) balance feature designed and constructed to withstand reverse pressure differentials without opening. Refer to 6.1.1.11 and Figure 10.

- a) In static operation, the seal shall be able to contain the rated process pressure in the event that barrier fluid pressure is lost.
- b) In static operation, the seal shall be able to contain the rated barrier pressure in the event that process pressure is atmospheric. (This is a seal qualification test point.)
- c) In dynamic operation, the seal shall be capable of operation for a time period agreed between the purchaser and the vendor to allow orderly pump shutdown upon loss of gas or liquid barrier fluid pressure.
- d) In continuous dynamic operation, the purchaser shall inform the seal vendor if the seal shall be required to operate continuously under abnormal conditions such as at rated barrier pressure with atmospheric pressure in the pump (gas or liquid barrier) or at rated process pressure if barrier pressure is lost for gas barrier seals. The purchaser shall advise the vendor of these abnormal conditions.

NOTE The internal or reverse balance feature requires that the mating ring and the secondary seal be designed to stay in place and contain pressure in the event that either the barrier fluid or the process pressure is lost. Continuous, dynamic operation under these special conditions may have an impact on the selection of the seal design and configuration as well as the selection of the seal cooling system.

7.3.1.3 Standard Arrangement 3 configurations shall utilize two seal rings and two mating seal rings. If recommended by the vendor and approved by the purchaser, a common mating ring (mono-block design) may be provided.

7.3.2 Seal Chamber and Gland Plates

- **7.3.2.1** If specified as a result of the process conditions and if additional length for the seal arrangement is available, a fixed throttle bushing made of carbon shall be installed in the gland plate and positively retained against pressure blowout.

The specification of a throttle bushing for a dual seal is rarely required, but may be used in services where a quench is used to avoid icing.

NOTE Limited axial space between the seal-chamber face and the bearing housing often makes the use of a throttle bushing with an Arrangement 3 seal impractical.

- **7.3.2.2** If specified, or recommended by the seal supplier and approved by the purchaser, a flush connection to the process side of the seal chamber shall be provided with Arrangement 3 configurations.

Some Arrangement 3 configurations may require a flush on the process fluid side of the seal chamber to isolate the process fluid from the seal parts or to assist in heat removal from the inner seal. Toxic and/or difficult-to-seal applications may utilize a flush in the seal chamber in addition to an Arrangement 3 seal.

7.3.2.3 Seal systems that utilize internal circulating devices shall comply with 7.1.2.7 through 7.1.2.11.

7.3.3 Contacting Wet Seal Configurations with a Liquid Barrier Fluid (3CW-FB, 3CW-FF, 3CW-BB)

7.3.3.1 General

Liquid-barrier systems shall be designed such that the maximum temperature differential between the barrier fluid inlet and outlet immediately adjacent to the seal chamber is:

- 8 °C (15 °F) for glycol/water or barrier fluids with viscosity close to that of water and
- 16 °C (30 °F) for oil barrier fluids.

NOTE 1 The allowable temperature differential includes the effects of both “heat soak” and seal-face-generated heat. The allowable temperature differential across the seal should not be confused with the rise in bulk temperature of the barrier fluid during steady-state operation or with the differential temperature between the pump fluid and steady-state barrier fluid temperature.

NOTE 2 See NOTE 2 in 7.2.3.1.

7.3.3.2 Default Seal Types and Arrangements

7.3.3.2.1 Unless otherwise specified, the configuration shall have the inner and outer seals arranged in a face to back configuration (see Figure 5, 3CW-FB).

NOTE The series configuration is preferred because any abrasive contamination is centrifuged out and has less effect on the inner seal and, in the event of loss of barrier fluid pressure, the seal will behave like an Arrangement 2 seal.

- **7.3.3.2.2** If specified, a face-to-face (3CW-FF) or a back-to-back (3CW-BB) configuration shall be provided (Figure 5).

NOTE The installed population of Arrangement 3 seals arranged in series (3CW-FB) is relatively small compared to the other configurations (3CW-FF and 3CW-BB). Both back-to-back and face-to-face configurations (3CW-BB and 3CW-FF) potentially offer more compact designs and can provide higher levels of performance. A purchaser's option for alternative Arrangement 3 configurations (3CW-FF and 3CW-BB) is provided.

7.3.4 Default Seal Types and Arrangements for Noncontacting Seal Configurations with a Gas Barrier Fluid (3NC-FB, 3NC-FF, 3NC-BB)

7.3.4.1 The default seal shall be a back-to-back (3NC-BB) configuration (Figure 6). If the pump seal chamber and casing is a not a self-venting design, then gas from inner seal leakage may accumulate in the pump during long idle periods and may require the pump to be vented prior to operation.

7.3.4.2 The purchaser should verify that any special pump casing vent needs are satisfied.

8 Accessories

8.1 General

8.1.1 Sealing systems consist of a seal arrangement and external accessories to operate the seal arrangement according to specified piping plans. The selection of the piping plans depends on the application and is described in Annex A sheets 7 to 9.

8.1.2 The purchaser and the mechanical seal manufacturer shall mutually agree which piping plan or plans (refer to Annex G) shall be realized to meet the seal chamber pressure and temperature requirements of 6.1.2.14.

- **8.1.3** If specified the arrangement of the equipment, including piping and auxiliaries, shall be developed jointly by the purchaser and the vendor. The arrangement shall provide adequate clearance areas and safe access for operation and maintenance.

8.1.4 Piping, components, and appurtenances in seal flush, vent and drain, buffer, and barrier systems services shall have a pressure–temperature rating at least equal to the maximum allowable working pressure and temperature of the pressure casing to which the system will be attached, but in no case shall they be suitable for gauge pressures less than:

- Category 1: 2.0 MPa (20 bar) (300 psi) at ambient temperature;
- Category 2 and Category 3: 4.0 MPa (40 bar) (600 psi) at ambient temperature.

NOTE 1 For high-discharge pressure pumps, where the seal chamber pressure can get higher than the MAWP of the seal, purchasers may want to consider the installation of a pressure relief valve in the suction piping of the pump, downstream of the suction block valve, instead of building the seal auxiliary system to the MAWP of the pump casing. The relief valve may be arranged to exit on the upstream side of the suction block valve. For further information about relief valves refer to 9.8.

NOTE 2 The gas pressure in a Piping Plan 53A may in some combined circumstances result in an operational increase in the reservoir pressure in excess of the design MAWP. This is caused by a combination of supply valve arrangement (not covered by this standard) and increases in ambient temperature and liquid volume (see Annex F). The purchaser should evaluate the impact of temperature and liquid volume changes on the reservoir pressure.

NOTE 3 This risk is low on systems pressurized by plant gas supply systems that rarely operate above gauge pressures of 1 MPa (10 bar) (150 psi).

8.1.5 Some piping plans require the provision of a buffer or barrier medium at a specific pressure. Therefore, the corresponding seal auxiliary systems are connected to external pressurization systems,

which are provided by the purchaser. A pressurization system shall not exceed the dynamic pressure rating of the seal and the MAWP of the seal auxiliary system.

NOTE For Piping Plan 53A and Piping Plan 53B the liquid barrier medium can be pressurized by an external gas system. If necessary, e.g. to reduce the pressure differences within the seal, the same can be done for Piping Plan 52. The pressurization system for Piping Plan 54 can be part of the seal auxiliary system or also be external. The seal auxiliary systems for the Piping Plan 72 and Piping Plan 74 are connected to external gas systems that provide pressurized gas.

8.1.6 Filling/refilling systems for liquid buffer and barrier mediums can also be attached to some closed seal auxiliary systems. These filling/refilling systems shall not exceed the dynamic pressure rating of the seal and the MAWP of the seal auxiliary system.

NOTE Filling/refilling systems for buffer and barrier systems are normally used for the Piping Plans 52, 53A, 53B, and 53C. Users should consider the effect of filling on the system pressure. While the standard does not allow the pressure to exceed the seal or system MAWP, the pressure will rise when closed systems are refilled and may exceed the pressure of the gas supply system. See Annex F for examples.

8.1.7 Unless otherwise specified, all components for piping plans listed in Table 4 and in the column "Process-Flush-Buffer-Barrier" shall be the same material as the seal gland or one with superior corrosion resistance and mechanical properties. For further information about suitable metals, refer to Table B.1.

NOTE When specialized alloys may be required for the flush piping and barrier/buffer systems, purchasers may consider whether these materials are required for services such as Piping Plans 32, 53, 54, 55, 72, and 74 as the components do not normally see the process fluid.

8.1.8 Local operation, venting, filling, and draining shall be accomplished from grade. Unless otherwise specified systems that require the use of a ladder or step or that require climbing on the baseplate or piping are not acceptable

8.1.9 Unless otherwise specified fill and vent of seal auxiliary systems shall be accomplished from grade. Systems that require the use of a ladder or step or that require climbing on the baseplate or piping are not acceptable.

8.1.10 Closed systems (Piping Plan 52, 53, 23, etc.) shall be designed with adequate fill and vent connections to allow initial and top up filling without trapping air or other vapor in the system.

8.1.11 All seal auxiliary systems shall incorporate vents as necessary to remove air and vapor and drains to allow safe removal of liquids.

8.1.12 When designing the vent piping to a vapor recovery system, the purchaser should take into account the potential for condensation of hydrocarbon vapors from other sources connected to that system. Additional condensation-collection vessels and/or heat tracing of the vent lines may be required to avoid buildup of a static liquid head in the vent piping and the possible contamination of the barrier/buffer fluid.

8.1.13 The method of filling the system shall be considered during the engineering phase of a project to provide a means to fill the seal; this may be required to be achieved under pressure (to prevent a pressure reversal for barrier fluid applications). A closed-fill system, one which enables the operator to fill the reservoir without exposure to the barrier/buffer fluid is required. Manual filling by using a funnel is not permitted. Some examples include:

- a centrally located tank that is permanently connected by piping to various reservoirs and/or day tanks utilizing, a transfer pump, or inert gas pressure to transfer the barrier/buffer fluid;
- a hand pump that can be connected to a day tank or drum with a hose or removable spool piece;
- a small vessel, located adjacent to the reservoir, which can be pressurized with an inert gas to force the barrier/buffer fluid into the reservoir.

8.2 Piping for Seal Auxiliary Systems

8.2.1 Seal auxiliary systems are part of the seal piping system and shall comply with the requirements of Table 4, Table 5, and Table 6.

8.2.2 Seal auxiliary systems shall include tubing, piping, isolating valves, control valves, relief valves, temperature gauges and thermowells, pressure gauges, sight flow indicators, orifices, barrier/buffer fluid reservoirs, and all related vents and drains as shown in Annex G.

Unless otherwise specified the supplier specified on the datasheet shall furnish all seal auxiliary piping systems, including mounted appurtenances, located within the confines of the associated pump's base area, any barrier/buffer fluid reservoir base area, or any auxiliary base area. If piping is furnished, it shall terminate with flanged connections at the edge of the base. The purchaser shall furnish only interconnecting piping or tubing between equipment groupings and off-base facilities.

8.2.4 In order to reduce the pressure drop within the system, the length of the lines and the use of fittings between the reservoir and gland plate shall be minimized. All lines shall slope up from the pump gland to the reservoir at a minimum of 40 mm per 240 mm ($1/2$ in. per ft), using smooth long radius bends.

8.2.5 Unless otherwise specified the total length of connection piping between the mechanical seal and the seal auxiliary system shall not exceed 5 m (16.4 ft) in length. For piping diameters refer to 8.2.8 and for further general information to Annex F.

8.2.6 The mechanical design of auxiliary tubing or piping systems shall achieve the following:

- a) proper support and protection to prevent damage from vibration or from shipment, operation, and maintenance;
- b) proper flexibility and normal accessibility for operation, maintenance and thorough cleaning;
- c) installation in a neat and orderly arrangement adapted to the contour of the machine without obstructing access to pump coupling from at least one side or other access openings required for maintenance;
- d) elimination of air pockets by the use of valved vents or nonaccumulating piping arrangements;
- e) complete drainage through low points without disassembly of piping, seal, or gland plate components;
- f) reduction of the number of potential emission sources and pressure drop by minimizing the use of threaded connections, flanges, fittings and valves;
- g) the system should be suitable for any special cleaning/decontamination procedures identified by the purchaser (i.e. steam cleaning, solvent wash, etc.).

8.2.7 Unless otherwise specified, seamless pipe or tubing shall be furnished in accordance with Table 4, Table 5, and Table 6 for all auxiliary systems.

8.2.8 Unless otherwise specified, lines connecting the barrier/buffer fluid system to the mechanical seal shall be tubing in accordance with 8.1.7, Table 4, and the following:

- 12 mm ($1/2$ in.) minimum, for shaft diameter 60 mm (2.5 in.) and smaller;
- 20 mm ($3/4$ in.) minimum, for shaft diameter greater than 60 mm (2.5 in.) or if flush flow rate exceeds 8 L/min (2 U.S. gal/min) or if the total length of connection pipework between seal and auxiliary system exceeds 5 m (16.4 ft) in length.

NOTE Refer to Annex F.

Table 4—Minimum Requirements for Auxiliary Piping

Component	Fluids and Piping Plans						
	Process-Flush-Barrier-Barrier			Quench		Cooling Water	
	inner seal	between seals	leakage recovery	to/from atmospheric seal area		to/from heat exchanger/cooling coil	
	11,12,13,14,21,22,23,31,32,41	52,53A,53B,53C,54,55,72,74	65,66A,66B,75,76	62		21,22,23,41,52,53A,53B,53C,54,55	
	Fluid Characteristics			Gauge Pressure		Nominal Size	
nonflammable, nonhazardous		flammable, hazardous	≤0.5 MPa (5 bar) (75 psi)	>0.5 MPa (5 bar) (75 psi)	Standard ≤DN 25 (NPS 1)	Optional ≥DN 40 (NPS 1 1/2)	
Pipe	seamless			seamless			carbon steel (ASTM A120 Schedule 40 galvanized to ASTM A153)
Tubing	stainless steel (ASTM A269 seamless Type 316)			stainless steel (ASTM A269 seamless Type 316)		stainless steel (ASTM A269 seamless Type 316)	
All Valves	Class 800			Class 800		Class 200 bronze	
Gate and Globe Valve	bolted bonnet and gland			bolted bonnet and gland			
Pipe Fittings and Unions	forged Class 3000			forged Class 3000		malleable iron (ASTM A338 and A197 Class 150) galvanized to ASTM A153	
Tube Fittings	manufacturer's standard			manufacturer's standard		manufacturer's standard	
Fabricated Joints ≤DN 25 (NPS 1)	threaded	socket-welded		threaded	socket-welded	threaded	socket-welded
Fabricated Joints ≥DN 40 (NPS 1 1/2)							Purchaser to specify
Flange Gaskets			Type 304 or 316 stainless steel spiral wound			Type 304 or 316 stainless steel spiral wound	
Flange Bolting			Low alloy steel (ASTM A193 Grade B7 ASTM A194 Grade 2H)			Low alloy steel (ASTM A193 Grade B7 ASTM A194 Grade 2H)	
Plugs	metallic solid round or solid hexagonal head plugs in accordance with the dimensional requirements of ASME B16.						
<p>The ASTM standards listed are examples of acceptable materials for each type. Alternate materials may be used if agreed by the purchaser (Annex B may be used for guidance). Examples of acceptable materials are:</p> <ul style="list-style-type: none"> — carbon steel pipe: ASTM A53 Grade B, ASTM A106 Grade B, ASTM A524 or API Spec 5L Grade A or B; — carbon steel fittings, valves and flanged components: ASTM A105 and ATMS A181; — stainless steel piping ASTM A312 Type 316L; — stainless steel fittings, valves and flanged components: ASTM A812 Type 316L. 							
<p>^a These requirements only refer to the external piping. The design requirements for heat exchangers and cooling coils are specified in 8.3.2 and 8.3.6.2.13.</p>							

Table 5—Minimum Pipe Wall Thickness

Materials	Nominal Pipe Size Minimum		
	DN	NPS	Schedule
Carbon steel	DN 15 to DN 40	1/2 to 1 1/2	80
	DN 50 to DN 200	2 to 8	40
	>DN 200	>8	20
Stainless steel	DN 15 to DN 40	1/2 to 1 1/2	80S
	DN 40 to DN 75	1 1/2 to 3	40S
	DN 100	4	10S

Table 6—Minimum Tubing Wall Thickness

Nominal Tubing Size ^a		Minimum Wall Thickness	
mm	in.	mm	in.
12	1/2	1.5	0.065
20	3/4	2.0	0.095
25	1	2.6	0.109

^a The tubing size is the outside diameter.

- **8.2.9** If specified, Schedule 80, austenitic stainless steel piping in accordance with Table 4 and the following shall be provided:
 - 12 mm (1/2 in.) minimum, for shaft diameter 60 mm (2.5 in.) and smaller;
 - 20 mm (3/4 in.) minimum, for shaft diameter greater than 60 mm (2.5 in.) or if flush flow rate exceeds 8 L/min (2 U.S. gal/min) or if the total length of connection pipework between seal and auxiliary system exceeds 5 m (16.4 ft) in length.

8.2.10 Piping design and joint fabrication, examination and inspection shall comply with ISO 15649 or ASME B31.3. Welding shall be performed by operators and procedures qualified in accordance with the appropriate part of EN 287 and EN 288, or ASME IX.

8.2.11 Piping shall be fabricated by bending and welding to minimize the use of flanges and fittings where practical. Welded flanges are permitted only at equipment connections, at the edge of any base, and for ease of maintenance. The use of flanges at other points is permitted only with the purchaser's specific approval. Other than tees and reducers, welded fittings are permitted only to facilitate pipe layout in congested areas. Threaded connections shall be held to a minimum. Pipe bushings shall not be used.

8.2.12 Tubing shall be fabricated by bending and the use of compression fittings. Piping or tubing shall not be welded if the wall thickness is less than 2.5 mm (0.1 in.). This includes fixation of external fins or other surface area extension devices on the OD of the pipe or tube. Connections that are internal to auxiliary devices are not permitted including coolers and seal reservoirs. This includes but is not limited to welding, brazing, and compression fittings. Connection methods for fins on pipe or tube shall be suitable for the maximum specified operating temperature of the pump. Fabricated joints for Piping Plan 72 and Piping Plan 74 auxiliary systems shall be butt welded instead of socket welded.

NOTE 1 Leaky internal connections are difficult to discover and may cause the contamination, vaporization and excessive pressurization of the cooling water.

NOTE 2 Socket welding creates a cavity for debris accumulation that can subsequently damage a gas seal.

- **8.2.13** Pipe shall have tapered threads in accordance with ISO 7 or ASME B1.20.1, as specified by the purchaser. Flanges shall be in accordance with ISO 7005-1. Slip-on flanges may be used only with the purchaser's approval. For socket-welded construction a 1.5 mm ($1/16$ in.) gap shall be left between the pipe end and the bottom of the socket.

NOTE For the purpose of these provisions, ASME B16.5 is equivalent to ISO 7005-1.

8.2.14 The following nominal sizes of connections, piping, valves and fittings shall not be used: DN 30 (NPS 1 $1/4$), DN 65 mm (NPS 2 $1/2$), DN 90 (NPS 3 $1/2$), DN 125 (NPS 5), DN 175 (NPS 7), or DN 225 (NPS 9).

- **8.2.15** Special requirements for piping, flanges, gaskets and o-rings, valves and other appurtenances in special and/or hazardous service shall be specified by the purchaser.
- **8.2.16** The purchaser shall specify if chlorides are present in a concentration above 10 mg/kg (parts per million by weight). Caution should then be used in applying stainless steel because of the potential for chloride stress-corrosion cracking.

8.2.17 The minimum nominal size of any connection—other than the gland plate—or piping shall be DN 15 (NPS $1/2$). Gland plate connections shall be in accordance with 6.1.2.17. The sizing of the internal piping and connections in auxiliary system for Piping Plan 72 and Piping Plan 74 shall be according to the vendor standard.

8.2.18 Piping systems furnished by the vendor shall be fabricated, installed in the shop, and properly supported. Bolt holes for flanged connections shall straddle lines parallel to the main horizontal or vertical centerline of the equipment.

8.2.19 Tapped openings not connected to piping shall be plugged with solid round or solid hexagonal head plugs furnished in accordance with the dimensional requirements of ASME B16.11. Square head plugs shall not be used because of their tendency to be damaged during installation and removal. All plugs shall be of the same material as the gland plate. An anaerobic lubricant/sealant shall be used on the threads to ensure the threads are vapor tight.

8.2.20 For pressure ratings above ASME Class 900, block valves shall be of welded-bonnet or no-bonnet construction with bolted gland; these valves shall be capable of being repacked under pressure.

- **8.2.21** Galvanized pipe shall be used for cooling water lines.
- **8.2.22** If specified, sight flow indicators (open or closed as specified) shall be furnished in each cooling water outlet line.

8.2.23 Cooling-water lines shall be heat traced in freezing climates.

- **8.2.24** If specified, each utility, such as air and inert gas supplies, cooling water supply and return lines, and others as specified, shall be manifolded to a common connection. The manifold shall be of sufficient dimensions to handle the maximum flow-through of all components that may require simultaneous use of the specified utility.

8.3 Components of Seal Auxiliary Systems (if Specified in Annex G)

8.3.1 General

If a piping plan in Annex G includes a component described in this section, that component shall meet the requirements of this section. Not all piping plans will have all of the components described in this section.

8.3.2 Coolers

8.3.2.1 General

8.3.2.1.1 If furnished, external-seal flush coolers shall be in accordance with 8.3.2.1.2 to 8.3.2.1.12. Requirements for coolers mounted within or integral to barrier/buffer fluid reservoirs are given in 8.3.6.2.13.

NOTE External-seal flush coolers mounted in the seal flush piping may be considered as a viable means of creating the required product temperature margin (see 6.1.2.14).

- **8.3.2.1.2** If specified by the purchaser, or if required by local regulations, the seal flush coolers shall be designed, fabricated, and inspected in accordance with ISO 15649 or ASME B31.3 using piping components.

8.3.2.1.3 For all between-bearing pumps, a separate external seal flush cooler shall be provided for each mechanical seal.

8.3.2.1.4 An austenitic stainless steel tag shall be securely fastened to all coolers provided with seal Piping Plan 23. In letters a minimum of 6 mm ($\frac{1}{2}$ in.) high, this tag shall read: "IMPORTANT: ALL TRAPPED GAS SHALL BE VENTED FROM THIS SYSTEM PRIOR TO OPERATION TO PREVENT DAMAGE TO THE MECHANICAL SEAL."

8.3.2.1.5 For separate coolers mounted in Piping Plan 23 flush loops and for external coolers in buffer/barrier systems see Figure G.37 and Figure G.38 for recommendations.

NOTE When the pump shaft is stationary and in a standby mode, localized cooling to improve the seal life can be achieved within the auxiliary system by use of a thermosyphon principle. This mechanism requires a minimum difference in height between the heat exchanger and the seal.

- **8.3.2.1.6** If Piping Plan 23 is specified, a positive circulating device shall be provided. The circulation device shall be in accordance with 7.1.2.7 to 7.1.2.11. The purchaser shall specify if an external circulating pump or a flow-through system from an external source is required.

8.3.2.1.7 The tubes shall be of austenitic stainless steel and shall have a minimum outside diameter of 12 mm (0.5 in.) and a minimum wall thickness of 1.5 mm (0.065 in.). No tubing connectors, fittings, or seams mounted internal to the reservoir are allowed.

8.3.2.1.8 Seal flush coolers shall be sized for the seal manufacturer's recommended seal flush flow rates but shall not be sized for less than 8 L/min (2 U.S. gal/min) per seal.

8.3.2.1.9 The criteria for thermal sizing of the cooler and internal cooling coils of reservoirs shall be provided by the seal manufacturer. The seal manufacturer shall confirm that the selected cooler will meet the expected thermal duty requirements at the site utility conditions specified on the datasheets. For buffer/barrier systems the performance of the internal or external pumping device, combined with the total resistance of the flow circuit shall provide sufficient flow rate to achieve the limits defined in 7.2.3.1 and 7.3.3.1 (see also Annex F).

8.3.2.1.10 At low ambient temperature or high wind chill locations the selection of water coolers and air coolers should be reviewed because of possible freezing inside the cooler or connection piping.

8.3.2.1.11 The user shall design the cooling water system to avoid shell overpressurization resulting from blocking-in of the water side while high-temperature process fluid is passing through the tubes. This can be accomplished through adequate pressure rating of the shell, the addition of pressure-relief protection, or operating procedures.

8.3.2.1.12 Unless otherwise specified the cooling-water system shall be designed for the conditions specified in Table 7.

8.3.2.2 Water Coolers

8.3.2.2.1 Unless otherwise specified, seal flush coolers shall be arranged with the seal flush fluid on the tube side and the cooling water on the shell side.

8.3.2.2.2 If suitable cooling cannot be achieved with the given design and service parameters the vendor shall notify the purchaser. The vendor and the purchaser shall agree on an alternative solution.

8.3.2.2.3 Unless otherwise specified or required by 8.1.7 and 8.2.15 the tubes shall be of austenitic stainless steel type 316/316L or equivalent, the shell shall be of carbon steel.

8.3.2.2.4 The seal flush cooler shall be arranged for complete draining and venting of both the water and process sides. A drain valve (not just a plug) shall be mounted at the lowest point on the shell side.

Table 7—Conditions Affecting Cooling Water System Design

Condition	Value
Velocity over heat exchange surfaces	1.5 m/s to 2.5 m/s (5 ft/s to 8 ft/s)
Maximum allowable working pressure, gauge	0.7 MPa (7 bar) (100 psi)
Test pressure, gauge	See 10.3.3
Maximum pressure drop	0.1 MPa (1 bar) (15 psi)
Maximum inlet temperature	32 °C (90 °F)
Maximum outlet temperature	49 °C (120 °F)
Fouling factor on water side	0.35 m ² ·K/kW (0.002 hr·ft ² -°F/Btu)
Shell corrosion allowance ^a	3 mm (0.125 in.)
^a Not applicable for piping	

8.3.2.2.6 Welding of tubes or fillet welds at tube sheets with a tube wall thickness less than 2.5 mm (0.1 in.) is not allowed inside the cooler.

8.3.2.3 Air Coolers

8.3.2.3.1 Unless otherwise specified the air cooler shall be constructed with finned tubing and arranged with the seal flush fluid on the tube side. Unless otherwise specified or recommended by the seal vendor the cooler shall be a natural air draft cooler.

- **8.3.2.3.2** If specified or recommended by the seal vendor and agreed by the user forced draft air coolers shall be supplied. The design and engineering of forced draft air cooler systems shall be agreed between the purchaser and seal vendor.

8.3.2.3.3 Unless otherwise specified or required by 8.1.7 the tube shall be of austenitic stainless steel type 316, 316L, or 316Ti. If finned tubing is used the fins shall be of aluminum or stainless steel and fixed with a suitable bonding method. Austenitic stainless steel type 316L or 316Ti shall be used if fin-tube connections or tube-header connections are welded. For welded connections the minimum wall thickness shall be according to 8.2.12.

NOTE If a forced draft cooler is used the purchaser may consider the inclusion of a high-temperature alarm to warn of loss or limited air flow rate.

8.3.2.3.4 The air cooler design shall be arranged for complete draining and venting on the tube side.

8.3.2.3.5 Unless otherwise specified the design of the air cooler shall include a fouling factor $0.1 \text{ m}^2\text{K/kW}$ to $0.4 \text{ m}^2\text{K/kW}$ ($0.0006 \text{ hr-ft}^2\text{-}^\circ\text{F/Btu}$ to $0.0023 \text{ hr-ft}^2\text{-}^\circ\text{F/Btu}$) on the air side.

8.3.3 Strainer

8.3.3.1 Strainers are used in Piping Plan 12, Piping Plan 22, and Piping Plan 32 to remove large particles from normally clean fluids.

NOTE Strainers should be checked regularly to avoid blockage and loss of effectiveness.

8.3.3.2 The strainer mesh shall be of stainless steel and a minimum mesh size of $125 \mu\text{m}$.

8.3.4 Cyclone Separator

8.3.4.1 Unless otherwise specified, the seal flush system shall be designed so that the cyclone separator is the flow-limiting device.

8.3.4.2 Cyclone separators shall be selected to optimize removal of solids for a specific pump stage differential. If the pressure differential exceeds the cyclone separator design differential, a flow orifice may be used. Cyclone separators shall not be used with a pressure differential less than 0.17 MPa (1.7 bar) (25 psi).

NOTE 1 In order to effectively remove solids from the flush stream, the solids should have a density of at least twice that of the fluid. Some common materials frequently found in refinery process streams and their approximate densities are listed in Table 8. Therefore, for most hydrocarbon services where, except for initial start-up, the most likely solid contaminate is coke, a cyclone separator would most likely be ineffective. However, for inlet-water pumps taking suction from a river, bay or well, a cyclone separator can work if properly installed. Many users, however, specify cyclones for all pumps based on the assumption that during construction and major unit overhauls, debris, such as weld beads, sand and stones, can get into the piping and could cause a seal failure during startup.

NOTE 2 The efficiency of separation (percentage of solids carried over) of a cyclone also depends on differential pressure and particle size. As the differential pressure across the cyclone varies (increases or decreases) from the design differential, the separation efficiency usually is reduced. As the particle size decreases, separation efficiency also decreases.

8.3.4.3 For between-bearing pumps, a separate cyclone separator shall be provided for each mechanical seal.

8.3.4.4 Unless otherwise specified or required by 8.1.7, cyclone separators shall be austenitic stainless steel type 316, 316L, or 316Ti per Annex B.

8.3.5 Flow Control Orifice

8.3.5.1 The number and location of flow control orifices needed shall be determined by the vendor specified to furnish the auxiliary piping system, as specified in 8.2.3. An orifice may be required in the seal flush system solely or in conjunction with a throat bushing and/or cyclone separator to

- limit the seal flush circulation rate to the seal;
- control the seal chamber pressure.

NOTE 1 Frequently, buffer fluid reservoirs for Piping Plan 52 are continuously vented to a vapor recovery system. A flow control orifice, sized specifically for the system, is normally installed in the vent line to restrict the flow from the reservoir and to provide a back pressure on it.

NOTE 2 The pump vendor and the seal auxiliary system vendor have to clarify which orifices belong to their scope of supply.

Table 8—Approximate Densities of Materials Found in Process Streams

Substance Material	Density	
	kg/m ³	lb/ft ³
Cement, sand, stone	2307	144
Clay	1762	110
Coke	513	32
Earth (mud)	1538	96
Gasoline (relative density 0.7)	721	45
Glass	2595	162
Kerosene	801	50
Limestone	2355	147
Paraffin	897	569
Sand	2018	126
Steel	7801	487
Sulfur	2002	125
Tar	1201	75
Water	993	62
Wood (pine)	432	27

- **8.3.5.2** When piping is supplied a plate orifice or orifices shall be furnished and mounted in the auxiliary piping between a pair of flanges. If tubing is specified the same design shall be used with the flanges connected by unions to the tube. If specified or recommended by the vendor and approved by the purchaser a barstock orifice (also called an orifice fitting or orifice nipple) shall be supplied. Orifice unions shall not be used. To prevent leakage orifice fittings relying on a threaded connection shall not be used. A drilled piece of barstock that is fixed with compression fittings shall be used. All orifices shall have a minimum bore of 3 mm ($1/8$ in.). Unless otherwise specified, orifice plates shall have a tang that extends beyond the outside diameter of the flange. The tang shall be stamped with the bore diameter, line size, and plate material.

NOTE Orifice bores smaller than 3 mm ($1/8$ in.) become blocked more easily and can cause a seal failure.

8.3.5.3 Multiple orifices, installed in series, may be used if more pressure drop is required than can be taken in a single 3 mm ($1/8$ in.) orifice. Noise through an orifice can be excessive, especially when the flow rate is high. The purchaser and supplier shall ensure proper sizing of the orifice to minimize airborne noise.

- **8.3.5.4** If specified an orifice nipple (not an orifice union) shall be furnished at the pump discharge and/or suction nozzle to restrict leakage in the event of an auxiliary system pipe or component failure.

8.3.5.5 The material for flow control orifices shall be in accordance with 8.1.7.

8.3.5.6 If Piping Plan 66B is applied the drain connection of the gland plate shall be plugged with a socket hex-head plug of austenitic stainless steel type 316 with a drilled hole. For clean fluids with a viscosity less or equal to 5 mm²/s (5 cSt), the hole shall have a diameter of 1.5 mm (0.0625 in.). For fluids with a viscosity above 5 mm²/s (5 cSt) or that contain solids that may cause plugging, the hole shall have a diameter of 3 mm (0.125 in.).

8.3.5.7 The seal manufacturer shall confirm that the temperature at the exit of the orifice in the vent line from the reservoir is above the nil ductility transition temperature for the materials of construction. The effects of barrier/buffer fluid temperature and autorefrigeration of leakage across the orifice shall be reviewed to determine the design temperature of the components.

8.3.6 Barrier/Buffer Fluid Reservoirs and Accumulators

8.3.6.1 General

- **8.3.6.1.1** If a barrier/buffer fluid reservoir or an accumulator is specified, the purchaser and the mechanical seal manufacturer shall mutually agree on the sizing, instrumentation requirements, fluid selection, and general arrangement.

8.3.6.1.2 A separate reservoir or accumulator shall be furnished for each mechanical seal.

8.3.6.1.3 The barrier/buffer fluid reservoir or accumulator shall be mounted on a substantial support as specified on the datasheet and should not be affected by pump vibration (see 8.2.3).

8.3.6.1.4 Reservoirs and accumulators should be located leaving sufficient room for operation and maintenance and should not be located directly above the pump and should not be affected by pump vibration.

NOTE Provision should be made to prevent the heating effects of solar radiation on pressurized vessels and bladder accumulators (see Annex F).

8.3.6.1.5 Unless otherwise specified, all connections to a reservoir or an accumulator shall be threaded.

8.3.6.1.6 Unless otherwise specified, Piping Plan 53 accumulator and reservoir designs shall achieve a refill frequency of greater than twenty-eight days (28 d). The refill frequency shall be calculated by the vendor using 2 times the actual qualification test leakage rate adjusted linearly for the job seal size and barrier pressure versus the qualification test barrier pressure. The vendor and purchaser shall mutually agree to a solution for systems that do not meet the twenty-eight day (28 d) minimum refill frequency requirement.

- **8.3.6.1.7** If Piping Plans 52, 53A, 53B, or 53C are specified, a positive-circulating device shall be provided. The circulation device shall be in accordance with 7.1.2.6 to 7.1.2.10. The purchaser shall specify if an external circulating pump or a flow-through system from an external source is required. Systems that rely only on a thermosiphon to maintain circulation during normal operation shall not be used.
- **8.3.6.1.8** The purchaser shall specify on the datasheets the characteristics of the barrier/buffer fluid (see Annex A, Sheet 10 of the recommended selection procedure).
- **8.3.6.1.9** If specified the seal and/or pump manufacturer shall review the purchaser's selection of a barrier/buffer fluid.

8.3.6.1.10 The minimum barrier pressure shall ensure a pressure of 0.14 MPa (1.4 bar) (20 psi) above the maximum seal chamber pressure.

8.3.6.2 Barrier/Buffer Fluid Reservoirs

8.3.6.2.1 Unless otherwise specified, the barrier/buffer fluid reservoir shall be arranged as shown in Annex G (Figure G.35 and Figure G.36).

8.3.6.2.2 The height of the normal liquid level (NLL) in the barrier/buffer fluid reservoir above the gland plate of the associated pump shall be established by the seal manufacturer. It shall not be less than 1 m (3 ft). It shall be based on required flow rate, barrier/buffer fluid ambient conditions, reservoir location, system hydraulic resistance, and the positive circulating device's head versus flow performance characteristics and net positive suction head requirements.

8.3.6.2.3 Unless otherwise specified, the reservoir for 52 and 53A shall be equipped with an indicating pressure transmitter PIT sensing the vapor space above the high liquid level (HLL) in the reservoir.

NOTE Arrangement 2 seals equipped with a buffer fluid reservoir normally utilize a high-pressure alarm to indicate if the primary seal has failed. Arrangement 3 seals equipped with a barrier fluid reservoir normally utilize a low-pressure alarm to indicate a drop or loss of barrier fluid pressure.

- **8.3.6.2.4** Unless otherwise specified, the reservoir shall be equipped with a level transmitter and low-level alarm (LLA). When specified, a high-level alarm (HLA) shall be provided.

8.3.6.2.5 Unless otherwise specified, the reservoir shall be designed to meet the sizing criteria as follows (see Figure G.35 and Figure G.36).

a) The volume of liquid in the reservoir, at NLL, shall be a minimum of

- 1) 12 L (3 U.S. gal) for shaft diameters 60 mm (2.5 in.) and smaller,
- 2) 20 L (5 U.S. gal) for shaft diameters larger than 60 mm (2.5 in.).

b) The NLL shall be at least 150 mm (6 in.) above the LLA point.

NOTE A distance of 150 mm (6 in.) allows a convenient visual reference.

c) The volume of the vapor space in the reservoir above the NLL shall be equal to or greater than the liquid volume between the NLL and the LLA point.

NOTE The requirements in Items b) and c) provide adequate volume to allow for fluctuations in level while ensuring adequate vapor space above the liquid.

d) The HLL alarm point, if furnished, shall be at least 50 mm (2 in.) above the NLL.

NOTE A distance of 50 mm (2 in.) minimizes the amount of leaked product entering the reservoir while providing sufficient volume to prevent spurious alarms due to normal fluctuations in level.

e) The low-level alarm point shall be at least 50 mm (2 in.) above the top of the return connection.

NOTE The distance specified in Item e) allows the level to fluctuate but still cover the return nozzle.

f) The barrier/buffer return (inlet) to the reservoir shall be at least 250 mm (10 in.) above the barrier/buffer supply (outlet) connection.

g) The barrier/buffer supply (outlet) from the reservoir shall be at least 50 mm (2 in.) above the bottom of the reservoir. In addition, a valved drain connection, orientated to allow complete draining, shall be provided at the bottom of the reservoir. An internal stand-pipe may be installed in the reservoir.

NOTE Having the supply line exit the reservoir above the bottom prevents any particulate that may have settled out in the reservoir from being carried into the mechanical seal.

h) The type and size of the reservoir connections shall be in accordance with Table 4 and 8.2.8 or 8.2.9.

8.3.6.2.6 The barrier/buffer fluid reservoir shall be fabricated in accordance with 8.3.6.2.7 to 8.3.6.2.13

- **8.3.6.2.7** The standard reservoir shall be in accordance with Figure G.35. If specified, the reservoir shall be in accordance with Figure G.36.

8.3.6.2.8 The reservoir is part of the pump piping system. Unless otherwise specified or required by local code, the reservoir shall be designed, fabricated, and inspected in accordance with ISO 15649 or ASME B31.3 using piping components.

8.3.6.2.9 If the reservoir is built entirely of piping components, ISO 15649 or ASME B31.3 can be applied and provides adequate design for the reservoir just as it does for the pump suction and discharge piping. It is the user's responsibility to ensure that local codes do not require that reservoirs be built in accordance with a pressure vessel code such as EN 13445 or ASME VIII, Division 1. Unless otherwise specified, reservoirs shall be fabricated as follows:

- 12 L (3 U.S. gal) reservoirs shall be fabricated from DN 150 (NPS 6) Schedule 40 pipe;
- 20 L (5 U.S. gal) reservoirs shall be fabricated from DN 200 (NPS 8) Schedule 40 pipe.

8.3.6.2.10 A nameplate, stamped with the MAWP, hydrostatic test pressure, and the minimum and maximum allowable temperatures, shall be permanently attached to the reservoir.

8.3.6.2.11 Unless otherwise specified, the barrier/buffer fluid reservoir level gauge shall be a reflex weld pad with a visible range extending from 25 mm (1 in.) below the low-level alarm point to at least 75 mm (3 in.) above the NLL or, if furnished, 25 mm (1 in.) above the high-level alarm point, whichever is greater. Permanent marking to indicate normal level shall be provided.

8.3.6.2.12 Unless otherwise specified, the barrier/buffer fluid reservoir and any piping or components welded directly to the reservoir shall be austenitic stainless steel type 316L.

8.3.6.2.13 Unless otherwise specified, the barrier/buffer fluid reservoir shall be equipped with a cooling coil as follows.

- a) The design of the cooling coil shall comply with 8.3.2.1.7, 8.3.2.1.9, 8.3.2.1.10, 8.3.2.1.12, and 8.3.2.2.5.
- b) The coil shall be mounted internally to the reservoir such that the top of the coil is below the bottom of the return (inlet) connection. The cooling liquid shall be on the tube side.
- c) Reservoirs equipped with cooling coils that will not be used in the field installation shall have the cooling water inlet and outlet connection plugged with metal plugs.
- d) The cooling coil shall be arranged so that it can be completely drained.

8.3.6.3 Bladder Accumulator

8.3.6.3.1 The size of the bladder accumulator shall be in accordance with Table 9.

Table 9—Sizing of Bladder Accumulators

Shaft Size	Seal Category	Seal Chamber Gauge Pressure	Accumulator Nominal Size, Minimum
Less than or equal to 60 mm (2.5 in.)	Category 1	Less than 1.2 MPa (12 bar) (175 psi)	20 L (5 U.S. gal)
	Category 2 and 3	Less than 2.5 MPa (25 bar) (360 psi)	
Greater than 60 mm (2.5 in.)	Category 1	Less than 1.2 MPa (12 bar) (175 psi)	35 L (9 U.S. gal)
	Category 2 and 3	Less than 2.5 MPa (25 bar) (360 psi)	
Any	Category 1	Greater than 1.2 MPa (12 bar) (175 psi)	Designed
	Category 2 and 3	Greater than 2.5 MPa (25 bar) (360 psi)	

NOTE 1 Designing the size of the accumulator should include the site maximum ambient temperature and MAWP of the seal auxiliary system and the seal. A review of the impact of site maximum ambient temperature data on the barrier pressure should be made to check the MAWP of the auxiliary system and the dynamic seal pressure rating of the seal cartridge is not exceeded. If this occurs the purchaser and seal vendor should mutually agree a solution.

NOTE 2 The choice of accumulator sizes in this standard has been based on achieving comparative working liquid volumes to the reservoir sizes in 8.3.6.2 (refer to Annex F for more details).

NOTE 3 When the seal chamber pressure is greater than the values in this section there is the potential that high ambient temperature rises increasing the barrier pressure above the scope of this standard. Refer to F.3.3.3 for ways to limit the impact of ambient temperature variations on barrier pressure.

NOTE 4 The accumulator working liquid volume can be the liquid volume difference between maximum and minimum barrier liquid volume, but could be significantly less depending on the instrumentation and alarm strategy employed. Refer to F.3.3.3 for more detail.

8.3.6.3.2 The minimum liquid volume retained in the accumulator at the accumulator minimum barrier pressure condition shall be a minimum of:

- 0.2 L (0.05 U.S. gal) for 20 L (5 U.S. gal) nominal accumulator,
- 0.35 L (0.09 U.S. gal) for 35 L (9 U.S. gal) nominal accumulator.

The precharge gas pressure value shall be provided by the vendor based on minimum ambient temperature and recalibrated for setting at the temperature of gas in the bladder or ambient temperature during commissioning.

8.3.6.3.3 The maximum and minimum barrier pressure shall be calculated by the seal vendor at minimum ambient temperature, 25 °C (77 °F) and maximum ambient temperature. These values together with a method of estimating the maximum operating barrier pressure at intermediate temperature conditions shall be provided to the purchaser for the initial setting and subsequent replenishment of barrier fluid.

NOTE 1 The maximum operating barrier pressure is dependent on the temperature of the gas in the bladder at the time of filling or refilling. See Annex F for more detail on precharge gas and barrier pressure calculations.

NOTE 2 The bladder accumulator is normally piped and situated such that its bladder gas volume is not affected by the barrier liquid temperature changes, but is primarily influenced by local ambient temperature conditions. The corresponding barrier pressure fluctuations will assume the high and low ambient conditions apply to the gas in the bladder. Refer to Annex F for details regarding barrier pressure calculations.

8.3.6.3.4 Unless otherwise specified, bladder accumulators shall be equipped with a pressure transmitter on the liquid side and a temperature transmitter on the gas side to provide a pressure alarm with a temperature bias. The temperature transmitter shall measure the gas temperature in the accumulator. The output signal from these transmitters shall be available for connection to the plant distributed control system (DCS) for alarm calculation and function. Specific input for programming the DCS to establish the floating pressure alarm algorithm shall be provided by the vendor.

NOTE Specific input required for the alarm algorithm will typically include the minimum and maximum barrier liquid volume, the accumulator volume, and the minimum barrier system pressure at minimum ambient temperature. The vendor will use this data and the site ambient temperature data to optimize system design, minimize the frequency of refilling, and verify that the system design is suitable for the local installation. A typical working liquid volume is 15 % to 25 % of the accumulator volume. Refer to Annex F for more detail.

- **8.3.6.3.4.1** If specified or if the plant DCS system is not available, a locally mounted single loop controller shall be provided for each accumulator. Parameters used by the controller to establish the floating pressure alarm algorithm shall be provided by the vendor.

NOTE Refer to the NOTE in 8.3.6.3.4.

- **8.3.6.3.4.2** If specified, a pressure transmitter shall be supplied without a temperature transmitter.

NOTE The use of a fixed pressure alarm (pressure transmitter without a temperature bias) can only indicate accumulator minimum liquid volume based on a specific temperature. Even though the output from a single pressure transmitter can be used to indicate multiple alarm set points, the maximum ambient temperature should be used to calculate the pressure alarm set point because no local temperature compensation is possible (see 8.3.6.3.3). The alternate alarm strategy in this section cannot adapt the indication of accumulator minimum liquid volumes at more than one value at ambient temperature and as a consequence may significantly reduce the available accumulator working liquid volume (refer to Annex F for more detail).

8.3.6.3.5 Unless otherwise specified, when a fixed pressure alarm strategy is utilized the alarm set point shall not be less than the accumulator minimum barrier pressure calculated at the maximum ambient temperature.

NOTE This section only applies to fixed pressure alarm strategies in 8.3.6.3.4.2. See Annex F for more details.

8.3.6.3.6 Bladder accumulator shells shall be of carbon steel. Unless otherwise specified bladder materials shall be according to manufacturer's standard and compatible with the barrier liquid. Elastomeric components of seal auxiliary systems for Piping Plan 53B are often not suitable for temperatures above 200 °C (392 °F). The process and barrier fluid temperatures next to these components are normally much lower than the maximum allowable working temperature. Provided that a failure of these components doesn't represent a loss of containment, their temperature rating may be lower than the maximum allowable working temperature to which the system will be attached.

8.3.6.3.7 An austenitic stainless steel nameplate, stamped with at least the Pump Item Number, auxiliary piping system MAWP, the minimum and maximum allowable temperature, the barrier liquid, the nitrogen precharge pressure at minimum ambient temperature and every 5 °C temperature increment to maximum ambient pressure and the maximum barrier pressure to be achieved when the system is full at the specified nitrogen pre charge pressure. Lettering shall be a minimum of 6 mm (¹/₄ in.) high and shall be easily readable from grade. An example is given in Table 10.

8.3.6.3.8 The MAWP of the bladder accumulator shell shall exceed the maximum possible supply pressure of the nitrogen precharge system used.

8.3.6.3.9 The barrier fluid cooling circuit should be arranged in accordance with Figure G.37. If a water cooler is selected the height of the cooler in the barrier fluid circuit above the seal gland plate shall be established by the seal vendor. The height of the cooler shall not be less than 450 mm (18 in.).

8.3.6.4 Piston Accumulator

8.3.6.4.1 The barrier system shall contain an accumulator with a mechanism to provide the barrier fluid with a positive differential pressure above the seal chamber pressure. The differential pressure shall be a minimum 0.14 MPa (1.4 bar) (20 psi).

NOTE This ensures the inner seal operates with a minimal differential pressure and a positive barrier pressure is provided with unplanned excursions in the seal chamber pressure.

8.3.6.4.2 For shaft diameters equal or smaller than 60 mm the barrier minimum liquid volume in accumulator shall be 0.2 L (0.05 U.S. gal) and a maximum liquid volume of at least 2.8 L (0.7 U.S. gal). For shaft diameters above 60 mm the barrier minimum liquid volume in accumulator shall be of 0.35 L (0.09 U.S. gal) and a maximum liquid volume of at least 5.1 L (1.28 U.S. gal).

NOTE These working volumes are similar to the working volume of the two barrier reservoirs in 8.3.6.2.

8.3.6.4.3 Piston accumulators shall be equipped with a:

- differential pressure transmitter with a low-level alarm;

— level indicator and level transmitter with a low- and high-level alarm to warn if piston reaches minimum or maximum end position.

8.3.6.4.4 Unless otherwise specified piston accumulators and any piping or components welded directly to the accumulator shall be of the same material as the gland plate or one of a superior corrosion resistance (see 8.1.7). The secondary seals of the accumulator shall conform to 6.1.6.5.1 and 6.1.6.5.2 and be of a material compatible with both the process liquid and barrier liquid. Elastomeric components of seal auxiliary systems for Piping Plan 53C are often not suitable for temperatures above 200 °C (392 °F). The process and barrier fluid temperatures next to these components are normally much lower than the maximum allowable working temperature. Provided that a failure of these components does not represent a loss of containment, the component temperature rating may be lower than the maximum allowable working temperature to which the system will be attached.

8.3.6.4.5 A nameplate, stamped with at least the Pump Item Number, seal auxiliary system MAWP, and the barrier liquid, shall be permanently attached to the system.

8.3.6.4.6 The barrier fluid cooling circuit should be arranged in accordance with Figure G.37. If a water cooler is selected, the height of the cooler in the barrier fluid circuit above the seal gland plate shall be established by the seal vendor but shall not be less than 450 mm (18 in.).

- **8.3.6.4.7** If specified a temperature indicator shall be supplied.

Table 10—Nameplate for Bladder Accumulator

Refill/Precharge Accumulator			For Item No.: xxx								
Alarm Setting			For Item No.: xxx								
	Temperature		Gauge Pressure								
	°C	°F	Precharge			Refill			Alarm		
			MPa	(bar)	(psi)	MPa	(bar)	(psi)	MPa	(bar)	(psi)
min.	-17	1	2.61	26.1	378	3.25	32.5	472	2.63	26.3	382
	-15	5	2.63	26.3	381	3.28	32.8	476	2.65	26.5	385
	-10	14	2.68	26.8	389	3.34	33.4	485	2.71	27.1	393
	-5	23	2.73	27.3	396	3.41	34.1	495	2.76	27.6	400
	0	32	2.79	27.9	404	3.47	34.7	504	2.81	28.1	408
	5	41	2.83	28.3	411	3.54	35.4	513	2.86	28.6	415
	10	50	2.88	28.8	418	3.60	36.0	522	2.92	29.2	423
	15	59	2.94	29.4	426	3.67	36.7	532	2.96	29.6	430
	20	68	2.99	29.9	433	3.73	37.3	541	3.02	30.2	438
normal	25	77	3.03	30.3	440	3.79	37.9	550	3.07	30.7	445
	30	86	3.09	30.9	448	3.85	38.5	559	3.12	31.2	453
	35	95	3.14	31.4	455	3.92	39.2	568	3.17	31.7	460
	40	104	3.19	31.9	463	3.99	39.9	578	3.22	32.2	467
	45	113	3.24	32.4	470	4.05	40.5	587	3.28	32.8	475
	50	122	3.30	33.0	478	4.11	41.1	596	3.32	33.2	482
	55	131	3.34	33.4	485	4.17	41.7	605	3.38	33.8	490
	60	140	3.39	33.9	492	4.24	42.4	615	3.43	34.3	497
	65	149	3.45	34.5	500	4.30	43.0	624	3.48	34.8	505
max.	70	158	3.50	35.0	507	4.36	43.6	633	3.53	35.3	512
Caution:	Do not adjust gas precharge pressure with liquid barrier fluid or pressure in the auxiliary piping system.										
Caution:	Do not add barrier liquid to exceed maximum refill pressure @ temperature										

8.3.7 External Circulating Pump

- **8.3.7.1** If specified, or if an internal circulating device cannot be provided to meet desired flow rates, an external forced-circulation pump will be required. Circulation pump selection shall be mutually agreed upon by the purchaser and the seal manufacturer. Where a failure of the external circulating pump could potentially result in a failure of the mechanical seal in the main pump, an interlock between the circulating pump and the main pump shall be considered.

8.3.7.2 Electrical equipment shall comply with IEC 60079 or NFPA 70 Articles 500-502 for the hazardous area classification specified by the purchaser.

8.3.8 Components for External Seal Flush Systems

- **8.3.8.1** If Piping Plan 32, Piping Plan 54, or Piping Plan 55 is selected (Figure G.14, Figure G.21, Figure G.22), the purchaser shall specify the fluid characteristics. The seal manufacturer shall specify the minimum flow rate, minimum pressure and temperature required, where these are factors.
- **8.3.8.2** If specified the seal and/or pump manufacturer shall review the purchaser's selection of external flush.

NOTE Inappropriate selection of flush or excessive flush flow rates can affect pump performance.

8.3.9 Collection Reservoir for Liquid Leakage

8.3.9.1 General

- **8.3.9.1.1** If leakage can solidify at ambient temperatures, the collector lines shall be heat-traced and insulated. If specified, the purchaser shall identify type and specification for heat tracing.
- 8.3.9.1.2** The purchaser shall provide any additional requirements for drain disposition.
- 8.3.9.1.3** The pipe from the gland plate to the collector shall have a minimum slope of 42 mm/m ($1/2$ in./ft) towards the collector. The minimum pipe size shall be DN 15 (NPS $1/2$).
- 8.3.9.1.4** All components supplied within the scope of Piping Plan 65 and Piping Plan 75, together with interconnecting pipework shall be considered part of the pump casing and meet the requirements of 8.1.4.
- 8.3.9.1.5** Unless otherwise specified, each seal assembly shall have an independent collection reservoir with instrumentation as specified in Figure G.25, Figure G.26, and Figure G.32.

8.3.9.2 Reservoir for Atmospheric Leakage (Piping Plan 65A and Piping Plan 65B)

- 8.3.9.2.1** The system shall comply with 8.3.9.2.2 to 8.3.9.2.5 and Figure G.25 or Figure G.26. Unless otherwise specified the reservoir shall include a level transmitter with a local indicator.
- 8.3.9.2.2** The reservoir shall have a volume of at least 3 L (0.75 U.S. gal).
- 8.3.9.2.3** The orifice for Piping Plan 65A shall have a bore diameter of at least 5 mm (0.2 in.).
- 8.3.9.2.4** The reservoir shall be in accordance with 8.3.6.2.8, 8.3.6.2.10, and Table 4. The components of the reservoir shall be fabricated from appropriate size, Schedule 40 pipe.
- 8.3.9.2.5** The upper drain connection of the reservoir shall be positioned below the drain connection of the gland plate.

8.3.9.3 Reservoir for Containment Seal Chamber Leakage (Piping Plan 75)

8.3.9.3.1 If a condensate collection system is provided, the system shall comply with 8.3.9.3.2 to 8.3.9.3.5 (see Figure G.32).

8.3.9.3.2 The condensate collection reservoir:

- a) shall be at least 200 mm (8 in.) diameter carbon steel, Schedule 40, and 12 L (3 U.S. gal) minimum capacity in accordance with 8.3.6.2.8, 8.3.6.2.10, and Table 4;
- b) shall have at least one flanged end cover for internal maintenance access;
- c) shall be fitted with a level gauge mounted on the flanged end cover;
- d) shall have a DN 20 (NPS $3/4$) minimum drain connection that terminates with a fully ported globe valve; and
- e) shall have a DN 15 (NPS $1/2$) minimum vent connection, to which a pressure indicator, a pressure transmitter with a HLA and a restriction orifice is installed to detect primary seal leakage.

- **8.3.9.3.3** A transmitter with a high-level alarm shall be provided, if specified.
- **8.3.9.3.4** A test connection shall be installed for injection of nitrogen to test containment seal and/or purge collector, if specified.

8.3.9.3.5 The vent restriction orifice of the leakage collection reservoir shall be below the drain connection of the seal gland plate.

8.3.10 Barrier/Buffer Gas Supply Systems

8.3.10.1 If a barrier/buffer gas system is specified, the purchaser and the mechanical seal manufacturer shall mutually agree on the instrumentation requirements and general arrangement.

8.3.10.2 Barrier/buffer gas supply systems shall be provided by the seal supplier and include components and instrumentation as specified in Figure G.30 and Figure G.31.

8.3.10.3 The minimum and maximum operating pressures shall also be within the range of the instrument. If possible, the pressure regulator, indicator, and transmitters shall be selected such that the normal operating pressure is in the middle third of the range.

8.3.10.4 A coalescing filter with a replaceable element or cartridge design shall be supplied and include a valved drain and liquid-level indicator. The coalescing filter shall have an efficiency of 98.8 % on particles of diameter equal or greater than 4 μm with a beta ratio $\beta_4 \leq 85$. It is critical that the supply of gas be effectively filtered. Seal face grooves can easily become blocked, where upon seal face separation decreases and rapid face wear can occur.

- **8.3.10.5** Unless otherwise specified an indicating pressure transmitter and indicating flow transmitter shall be provided upstream of the check valve. High pressure, high flow, and low flow shall be remotely alarmed from the transmitters. If specified a high-flow switch shall be provided and installed between the flow meter and the check valve (see Figure G.30 and Figure G.31).

8.3.10.6 Unless otherwise specified, each seal arrangement shall have an independent barrier/buffer gas supply system.

8.3.10.7 All external connections of the system shall be DN 15 (NPS $1/2$) minimum and in accordance with Table 4.

8.3.10.8 Unless otherwise specified gas supply systems shall be mounted on a metallic panel that has a minimum thickness of 6 mm (0.25 in.). All components shall be suitably supported to avoid damage to the components and internal piping/tubing.

9 Instrumentation

9.1 General

9.1.1 Unless otherwise specified, instrumentation and installation shall conform to this standard.

9.1.2 Unless otherwise specified, controls and instrumentation shall be designed for outdoor installation and shall comply with IEC 60529 designation IP 56 or with NEMA 250 enclosure Type 4.

9.1.3 Controls and instrumentation shall be made of materials compatible with the environment and fluids to which they will be exposed. Special consideration shall be given to all controls and instrumentation, such as level gauges and switches, exposed to the pumped fluid and barrier/buffer fluid (if any).

9.1.4 Instrumentation and controls shall be designed and manufactured for use in the specified area classification (class, group, and division or zone) stated in the datasheet.

9.1.5 All controls and instruments shall be located and arranged to permit easy visibility by the operators, as well as accessibility for tests, adjustments, and maintenance.

9.1.6 Unless otherwise specified the MAWP of instruments and accessories shall be at least equal to the piping or device into which they are mounted.

9.1.7 Instruments in contact with buffer/barrier/flush mediums shall be suitable for the normal operation temperatures of the buffer/barrier circuit but their temperature limit shall not be below 100 °C (212 °F). Provided that a failure of the instruments in a buffer/barrier circuit does not represent a loss of containment the temperature limit of an instrument may be lower than the maximum allowable temperature of the pump.

NOTE The temperature limit of some common instruments can be below the possible maximum allowable temperature of a pump. Many bourdon tube pressure gauges with liquid filling, for example, do normally have a temperature limit of about 100 °C (212 °F). The operation temperature of a buffer/barrier medium is often much lower than the maximum allowable temperature of the pump. If instruments need to be suitable for the possible maximum temperature of the pump special design features for the instrumentation have to be considered by the seal vendor.

- **9.1.8** If specified by the purchaser instrumentation in buffer/barrier circuits shall be suitable for the maximum allowable temperature of the pump.

9.2 Temperature-indicating Gauges

9.2.1 Dial temperature gauges shall be heavy duty and corrosion resistant. The gauges shall be bimetallic or liquid filled with a rigid stem suitable for mounting as needed. Mercury-filled thermometers shall not be acceptable. Black printing on a white background is standard style for gauge faces.

9.2.2 Dial temperature gauges shall be installed in pipe sections or in tubing runs as specified. Auxiliary equipment may be either piping or tubing. The owner shall specify whether gauges shall be placed in tubing or piping.

9.2.3 The sensing elements of temperature gauges shall be in the flowing fluid to the depth specified by the gauge manufacturer.

9.2.4 Temperature gauges installed in tubing shall be a minimum of 38 mm (1.5 in.) in diameter, and the stem shall have a minimum length of 50 mm (2 in.). All other gauges shall be a minimum of 90 mm (3.5 in.) in diameter, and the stem shall have a minimum length of 75 mm (3 in.).

NOTE The use of 90 mm (3.5 in.) gauge diameter instead of standard 125 mm (5 in.) is due to the normally small size of piping used in seal systems.

9.3 Thermowells

Temperature gauges that are in contact with flammable or toxic fluids or that are located in pressurized or flooded lines shall be furnished with separable threaded solid-bar thermowells made of austenitic stainless steel or another material more compatible with the liquid as defined by the manufacturer. Thermowells installed in piping shall be DN 15 (NPS $1/2$) minimum. Thermowells for use in tubing shall be approved by the purchaser. Thermowell designs and installation should not restrict liquid flow.

9.4 Pressure Indicators

9.4.1 Pressure gauges shall be in accordance with API 614.

9.4.2 Pressure gauges shall have block-bleed valves.

- 9.4.3 If specified, oil-filled pressure gauges shall be furnished.

9.5 Transmitters and Switches

9.5.1 General

9.5.1.1 Unless otherwise specified, each alarmed variable shall be furnished with one indicating transmitter located to facilitate inspection and maintenance.

- 9.5.1.2 If specified, switches shall be provided in place of transmitters. Switches shall be in accordance with API 614.

9.5.1.3 The purchaser shall specify output signal type, indicating or nonindicating (blind) type, analogue or digital type, housing and power supply requirements.

9.5.1.4 The purchaser shall specify transmitters that are nonhazardous, nonincendive, explosion-proof or intrinsically safe (IS), as required by the electrical area classification.

9.5.1.5 Unless otherwise specified transmitters shall be analogue, two-wire type and have an output of 4 mA to 20 mA.

- 9.5.1.6 Each indicating transmitter shall be located to facilitate unobstructed viewing. Read-out units shall be specified by the purchaser.

9.5.1.7 Unless otherwise specified or required in accordance with 8.1.7, sensing elements shall be of austenitic stainless steel. Each transmitter shall be equipped with a manifold to allow adjusting and testing. Each transmitter shall be arranged to permit testing, including, when possible the actuating element, without interfering with normal equipment operation.

9.5.1.8 If switches are specified instead of transmitters these devices should be substituted at locations shown for transmitters in Annex G.

9.5.2 Pressure Transmitters

9.5.2.1 Pressure transmitter shall be designed for the maximum pressure to which the transmitter may be exposed. Transmitters exposed to vacuum shall be suitable for full vacuum.

9.5.2.2 The measuring element and all pressure-containing parts shall be austenitic stainless steel type 316 unless the pumped fluid requires the use of alternative materials as determined by the seal manufacturer. Connections for pressure input shall be NPT $1/2$.

9.5.3 Level Transmitters

Unless otherwise specified, level transmitters shall be hydrostatic.

9.5.4 Flow Transmitters

Flow transmitters provided with buffer/barrier gas systems shall be inline, mechanically actuated, that respond to gas motion within the line.

9.6 Level Indicators

9.6.1 The standard level indicator shall be the weld pad reflex design.

- 9.6.2 If specified, an externally mounted, removable, reflex indicator shall be furnished instead of the standard weld pad design.

9.7 Flow Instruments

9.7.1 Flow Indicators

If used, flow indicators shall be of the nonrestrictive bull's-eye type and shall have a steel body. To facilitate viewing of the flow through the line, each flow indicator shall be installed in accordance with the manufacturer's instructions. The diameter of the bull's eye shall be at least one-half the inside diameter of the line and shall clearly show the minimum flow.

9.7.2 Flow Meters

Flow meters shall be armored rotameter or internal magnetic float design in accordance with the following.

- a) Rotameters shall be installed in the vertical position and piped in accordance with the vendor's recommendations.
- b) The capacity of the rotameter selected shall be such that normal flow rate falls in the middle one-third of the scale.
- c) A check valve shall be installed on the outlet of the meter to prevent back flow.
- d) Glass tube flow meters may only be used on air or inert gas at temperatures of 60 °C (140 °F) or less, and gauge pressures of 0.7 MPa (7 bar) (100 psi) or less.

9.8 Relief Valves

9.8.1 Unless otherwise specified, the manufacturer shall furnish the relief valves that are to be installed on equipment or in piping and tubing that the manufacturer is supplying. Other relief valves shall be furnished by the purchaser. Relief valves for all operating equipment shall meet the limiting relief-valve requirements defined in API 520, Parts I and Parts II, and if applicable in API 526 (diameter ≥ 1 in.). The manufacturer shall determine the size and set-pressure of all relief valves related to the equipment. The manufacturer's quotation shall list all relief valves and shall clearly indicate those to be furnished by the manufacturer. Relief valve settings, including accumulation, shall take into consideration all possible types of equipment failure and the protection of piping systems.

9.8.2 Unless otherwise specified, relief valves shall have steel bodies.

- 9.8.3 If specified, thermal relief valves shall be provided for components that may be blocked in by isolation valves.

9.9 Pressure Control Valves

Pressure control valves for gas buffer and barrier systems shall be supplied in accordance with the following.

- a) Pressure control valves shall be self-contained, spring-loaded with an internal pressure-sensing connection.
- b) The pressure control valve shall be designed such that the regulated pressure is applied directly to the diaphragm through the valve body.
- c) An adjusting device shall be provided with a locking mechanism to ensure that the control point cannot shift or be changed inadvertently.
- d) The pressure control valve body shall be rated for the maximum upstream and downstream pressure and temperature to which it may be subjected.
- e) Cast-iron valve bodies are not permitted. Cast aluminum, if approved by the purchaser, is permitted only in air or nitrogen service; spring and diaphragm housings shall be steel or stainless steel.
- f) Pressure control valves shall not be self-venting.

9.10 Pressure Amplifiers

A gas-pressure booster shall be provided if necessary to increase utility gas supply pressure.

10 Inspection, Testing, and Preparation for Shipment

10.1 General

10.1.1 Unless otherwise specified, the purchaser's representative shall have entry to all vendor and subvendor plants where manufacturing, testing, or inspection of the equipment is in progress.

10.1.2 The vendor shall notify submanufacturers of the purchaser's inspection and testing requirements.

10.1.3 The vendor shall provide sufficient advance notice to the purchaser before conducting any inspection or test that the purchaser has specified should be a witnessed test or an observed test.

- **10.1.4** The purchaser shall specify the extent of his/her participation in the inspection and testing. Unless otherwise specified, the vendor shall give the purchaser a minimum of five working days (5 d) notice for all observed and witnessed tests.

10.1.5 Unless otherwise specified, the purchaser's representative shall have access to the manufacturer's quality control program for review.

10.1.6 Equipment for the specified inspection and tests shall be provided by the vendor.

- **10.1.7** If specified, the purchaser, the vendor, or both, shall verify compliance with this standard and initial and date a completed checklist. An example of an inspector's checklist is given in Annex H.

10.2 Inspection

10.2.1 Pressure-containing parts shall not be painted until the specified inspection of the parts is completed.

- **10.2.2** In addition to the requirements of 6.1.6.10, the purchaser may specify the following:

- parts that shall be subjected to surface and subsurface examination and
- the type of examination required, such as magnetic-particle, liquid-penetrant, radiographic, or ultrasonic examination.

10.2.3 The nondestructive examination (NDE) shall be performed as required by the material specification. If additional radiographic, ultrasonic, magnetic particle, or liquid penetrant examinations of the welds or materials are specified by the purchaser, the methods and acceptance criteria shall be as follows. Alternative standards may be proposed by the vendor or specified by the purchaser.

- a) Radiography shall be in accordance with Section V, Article 2 and Article 22 of the ASME Code.
 - b) The radiographic acceptance standard used for welded fabrications shall be ASME VIII, Division 1, UW-51 (for 100 % radiography) and UW-52 (for spot radiography). The acceptance standard used for castings shall be ASME VIII, Division 1, Appendix 7.
 - c) Ultrasonic inspection shall be in accordance with ASME V, Article 5 and Article 23.
 - d) The ultrasonic acceptance standard used for welded fabrications shall be ASME VIII, Division 1, Appendix 12. The acceptance standard used for castings shall be ASME VIII, Division 1, Appendix 7.
 - e) Magnetic particle inspection shall be in accordance with ASME V, Article 7 and Article 25.
 - f) The magnetic particle acceptance standard used for welded fabrications shall be ASME VIII, Division 1, Appendix 6. The acceptance standard used for castings shall be ASME VIII, Division 1, Appendix 7.
 - g) Liquid penetrant inspection shall be in accordance with ASME V, Article 6 and Article 24.
 - h) The liquid penetrant acceptance standard used for welded fabrications shall be ASME VIII, Division 1, Appendix 8. The acceptance standard used for castings shall be ASME VIII, Division 1, Appendix 7.
 - i) Regardless of the acceptance criteria in Items b), d), f), and h), it shall be the manufacturer's responsibility to review the design limits of the equipment in the event that more stringent requirements are necessary. Defects that do not meet the acceptance criteria imposed in Items b), d), f), and h) above shall be removed to meet the quality standards cited, as determined by the inspection method specified.
 - j) During assembly of the system and before testing, each component (including cast-in passages of these components) and all piping and appurtenances shall be cleaned chemically or by another appropriate method to remove foreign materials, corrosion products, and mill scale.
- k) If specified, the hardness of parts, welds, and heat-affected zones shall be verified as being within the allowable values by testing of the parts, welds, or zones. The method, extent, documentation, and witnessing of the testing shall be mutually agreed upon by the purchaser and the manufacturer.

10.3 Testing

10.3.1 General

The sequence for seal testing is shown in Figure 27.

10.3.2 Seal Qualification Testing

10.3.2.1 Purpose

10.3.2.1.1 In order to provide the end user with a high degree of confidence that a manufacturer's commercial product seal will perform as required by this standard, each seal configuration in combination with other seal system attributes as noted in Annex I shall be suitably qualification tested by the seal

manufacturer prior to its market availability. The qualification test does not constitute an acceptance test. The intent is not to perform the qualification test for every individual seal cartridge or seal size in every qualification test fluid but to qualify specific seal configurations and attributes in specific qualification test fluids to simulate various process fluids and typical plant operation.

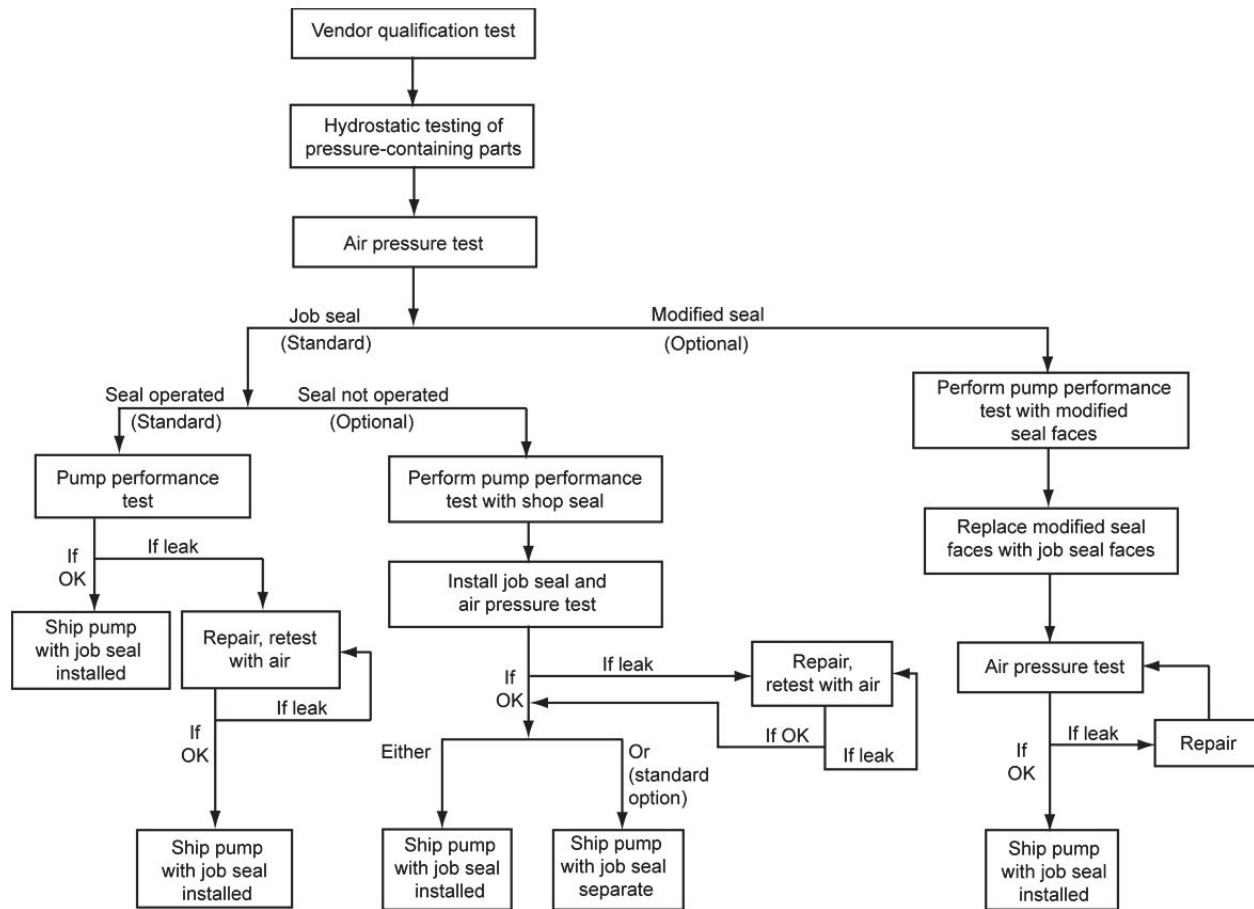

Figure 27—Seal Testing Sequence

10.3.2.1.2 If specified, optional testing shall be performed as mutually agreed upon by the seal manufacturer and the purchaser. The purchaser may specify test conditions that differ from the standard qualification test, as applicable.

10.3.2.2 Scope of Test

10.3.2.2.1 Qualification tests shall be conducted using an appropriate test rig by the seal manufacturer in accordance with Annex I.

10.3.2.2.2 To be qualified for a particular pumped fluid, a manufacturer's commercial product shall be successfully tested using the appropriate qualification test fluid as given in Table I.2.

NOTE A seal manufacturer's commercial product need be tested only in the representative qualification test fluid to its required service. It is not necessary to test a commercial product in all qualification test fluids. See Annex I for more information.

10.3.2.3 Minimum Performance Requirements

10.3.2.3.1 Unless otherwise specified to meet more stringent local emissions regulations, when single seals are tested in accordance with I.4.2, I.4.3, I.4.4, and I.4.9, the permitted leakage shall be:

- a concentration of vapors less than 1000 ml/m³ (1000 ppm vol);
- an average liquid leakage rate of less than 5.6 g/h per pair of seal faces.

NOTE 1 All mechanical seals require face lubrication to achieve reliability; this results in a minimal level of leakage, see F.1.1. On a water pump test of a contacting wet seal (1CW), the leakage typically evaporates and is not visible. Face design features, however, can increase leakage levels and visible droplets may occur. Pressurized dual contacting wet seals (3CW), when used with a nonevaporative, lubricating-oil barrier fluid, can also produce visible leakage in the form of droplets, but at a rate less than 5.6 g/h (two drops per minute).

NOTE 2 The owner or purchaser determines the applicable emission/leakage limits at the intended point of application and compares these limits to the values listed above for the qualification test. Local limits may be lower than the stated values. If an Arrangement 1 seal does not comply with local emission or leakage requirements, then Arrangement 2 or Arrangement 3 may be required to meet the applicable limits.

10.3.2.3.2 Unless otherwise specified to meet more stringent local emissions regulations, when containment seals are tested in accordance with I.4.5, the maximum permitted leakage concentration of vapors shall be 1000 ml/m³ (1000 ppm vol).

10.3.2.3.3 After completion of the qualification test, the total wear of the primary seal faces shall be less than 1 % of the available seal-face wear.

NOTE 1 Excessive wear of a single seal in a particular test can be an indication that a dual seal is the preferred selection for that service.

NOTE 2 Seal-face wear varies with size, speed, pressure and fluid, and is very nonlinear. Most seal-face wear occurs during startup or shortly thereafter.

10.3.2.3.4 For containment seals, the sum of the wear during testing according to I.4.2 to I.4.5 shall be less than 1 % of the available seal-face wear.

10.3.2.4 Results of Test

The seal manufacturer shall provide the results of the qualification tests and certification in accordance with Annex E. The results of the tests shall include at least the information shown on the qualification test results form Figure I.9 or Figure I.10. Any conditions observed that would jeopardize the ability of the seal to meet the reliability and performance requirements of this standard shall be reported.

10.3.3 Hydrostatic Test for Pressure-containing Mechanical Seal Parts and Accessories

10.3.3.1 Pressure-casing seal components, except gland plates machined from a single piece of wrought material or bar stock, shall be tested hydrostatically with liquid at a minimum of 1.5 times the MAWP of the pump casing to which the component is connected but not less than a gauge pressure of 0.14 MPa (1.4 bar) (20 psi). The test liquid shall be at a higher temperature than the nil ductility transition temperature of the material being tested.

10.3.3.2 If the part tested is to operate at a temperature at which the strength of a material is below the strength of that material at room temperature, the hydrostatic test pressure shall be multiplied by a factor obtained by dividing the allowable working stress for the material at room temperature by that at the operating temperature. The stress values used shall conform to those given in ASME B31.3 for piping or in EN 13445 or ASME VIII, Division 1 for vessels. The pressure thus obtained shall then be the minimum pressure at which the hydrostatic test shall be performed. The datasheets shall list actual hydrostatic test pressures.

10.3.3.3 Where applicable, tests shall be in accordance with the EN 13445 or ASME VIII. In the event that a discrepancy exists between the code test pressure and the test pressure in this standard, the higher pressure shall govern.

10.3.3.4 The chloride content of liquids used to test austenitic stainless steel materials shall not exceed 50 mg/kg (50 ppm wt). To prevent deposition of chlorides as a result of evaporative drying, all residual liquid shall be removed from tested parts at the conclusion of the test.

10.3.3.5 Tests shall be maintained for a sufficient period of time to permit complete examination of parts under pressure. The hydrostatic test shall be considered satisfactory when neither leaks nor seepage through the part are observed for a minimum of 30 min.

10.3.4 Test of Job Seal by Seal Manufacturer

10.3.4.1 Each mechanical seal shall be tested with air by the seal manufacturer after final assembly in accordance with 10.3.5. Provisions for the test shall include the requirements in 10.3.4.1 a) to 10.3.4.1 c).

- a) Seals shall be thoroughly inspected, cleaned, and faces verified to be free of lubricants and grease as they are assembled. The job type, size, material, and part number gasketing specified shall be used.
- b) The test fixture shall be capable of accommodating the entire seal without modification to the seal cartridge, seal chamber if provided by the seal manufacturer, or the gland plate.
- c) Arrangement 2 seals shall have provisions to test each sealing section independently.

10.3.4.2 Following the successful completion of the air test, the tested seal cartridge shall not be disassembled. The cartridge assembly shall be tagged with the words “certified seal manufacturer air test acceptable,” giving the test date and the inspector’s name.

10.3.4.3 In the event that the seal assembly does not pass the air test, the entire test shall be repeated until a successful test has been accomplished.

10.3.5 Assembly Integrity Test

10.3.5.1 Purpose

10.3.5.1.1 In order to provide the purchaser with a high degree of confidence that a manufacturer’s commercial product seal has been correctly assembled, each new or repaired cartridge assembly shall be tested in pressurized air or nitrogen by the seal manufacturer in accordance with 10.3.5 prior to shipment. This integrity test is an acceptance test.

NOTE The intent of the assembly integrity test is to show that the seal cartridge was assembled correctly. The seals are not expected to be leak-free, see A.1.3 for a tutorial on leakage. Many years of practical experience have shown that this simple low-pressure test is beneficial. Results from the assembly integrity test are not representative of the seal performance in liquid.

- **10.3.5.1.2** If specified, optional air or nitrogen testing shall be performed as mutually agreed upon by the seal manufacturer and the purchaser. The purchaser may specify test conditions that differ from the standard assembly integrity test, as applicable.

10.3.5.2 Scope of Assembly Integrity Test

10.3.5.2.1 Integrity tests shall be conducted using an appropriate test rig by the seal manufacturer in accordance with 10.3.5.2.2 to 10.3.5.2.5.

NOTE Typically a test rig simulates a large seal chamber using a canister having various connections, bolting, valves, and instrumentation. Adapters are used to accommodate a range of seal sizes.

10.3.5.2.2 The test rig shall have connections to test the simulated seal chamber, the buffer chamber, the barrier chamber, or the containment chamber independently in accordance with 10.3.5.3.

10.3.5.2.3 The test rig shall have a fill and pressurizing system capable of being isolated from the simulated seal chamber, the buffer chamber, the barrier chamber or the containment chamber that is being tested.

10.3.5.2.4 The volume of gas to be pressurized and tested in any of the chambers shall be a maximum of 28 L (1 ft³).

10.3.5.2.5 The pressure gauge used for the test shall have a range so that the gauge pressure of 0.17 MPa (1.7 bar) (25 psi) is close to the midpoint.

10.3.5.3 Procedure for Assembly Integrity Test

10.3.5.3.1 Each simulated seal chamber, buffer chamber, barrier chamber, or containment chamber being tested shall be independently pressurized with clean gas to a gauge pressure of 0.17 MPa (1.7 bar) (25 psi).

10.3.5.3.2 After pressurizing according to 10.3.5.3.1, isolate each simulated seal chamber, buffer chamber, barrier chamber, or containment chamber from the pressurizing source for five minutes.

10.3.5.4 Minimum Performance Requirements for Assembly Integrity Test

10.3.5.4.1 The maximum pressure drop during the test according to 10.3.5.3 shall be 0.014 MPa (0.14 bar) (2 psi).

NOTE 1 Pressure drop is inversely proportional to the volume being tested. This is an important consideration if the test chamber contains only a small volume of gas. When testing noncontacting seals, two sets of core seal components simultaneously, or field testing dual seals having a small volume of gas, special test conditions and/or acceptance criteria may apply. For example, assembly integrity tests of dual seals by testing both sets of core seal components simultaneously or field tests using small volumes of gas may exceed the criteria of 10.3.5.4.1 yet operate successfully in the intended service.

NOTE 2 Because of variations in volume, installation, and alignment, the results of the assembly integrity test may not be repeatable after installation.

10.3.6 Test of Job Seal by Pump Manufacturer

10.3.6.1 Modified Seal Faces

- If specified, the air-tested seal shall be supplied to the pump manufacturer with modified seal faces for operation during the pump performance test. Following the pump performance test, the job seal faces shall be installed in the seal and air tested in accordance with 10.3.5.

10.3.6.2 Seal Not Operated During Pump Performance Test

- If specified, the seal being supplied shall not be operated in the pump during the pump performance test, in order to prevent damage. During the pump performance test, the pump shall utilize a seal supplied by the pump manufacturer. The seal being supplied, and the seal chamber (if applicable), shall be installed after the pump performance test and air tested in accordance with 10.3.5. It shall be specified if the seal is to be shipped uninstalled.

10.4 Preparation for Shipment

10.4.1 Unless otherwise specified, the equipment shall be prepared for the type of shipment as described in 10.4.3.

10.4.2 The manufacturer shall provide the purchaser with the instructions necessary to preserve the integrity of the storage preparation after the equipment arrives at the job site and before start-up.

10.4.3 The equipment shall be prepared for shipment after all testing and inspection have been completed and the equipment has been released by the purchaser. The preparation shall include the following.

- a) Exterior surfaces, except for machined surfaces, shall be given at least one coat of the manufacturer's standard paint. The paint shall not contain lead or chromates. Stainless steel parts need not be painted.
- b) Carbon steel exterior machined surfaces shall be coated with a suitable rust preventive.
- c) The interior of the equipment shall be clean and free from scale, welding spatter, and foreign objects.
- d) Internal steel areas of carbon steel systems of any auxiliary equipment, such as reservoirs, shall be coated with a suitable oil-soluble rust preventive.
- e) Flanged openings shall be provided with metal closures at least 4.8 mm (³/₁₆ in.) thick, with elastomer gaskets and at least four full-diameter bolts. For studded openings, all nuts needed for the intended service shall be installed.
- f) Threaded openings shall be plugged in accordance with 6.1.2.18.
- g) Lifting points and the center of gravity shall be clearly identified on the equipment package if the mass exceeds 23 kg (50 lb) or if required by local regulations. The manufacturer shall provide the recommended lifting arrangement.
- h) For Category 3 seals, the equipment shall be identified with item and serial numbers. Material shipped separately shall be identified with securely affixed, corrosion-resistant metal tags indicating the item and serial number of the equipment, and shall be shipped with duplicate packing lists, one inside and one on the outside of the shipping container.

10.4.4 Auxiliary piping connections shall be die stamped or permanently tagged to agree with the manufacturer's connection table or general arrangement drawing. Service and connection designations shall be indicated.

10.4.5 One copy of the seal manufacturer's installation instructions shall be packed and shipped with the equipment.

11 Data Transfer

11.1 General

11.1.1 The transfer of the required data and documents is the joint responsibility of the purchaser and vendor. Unless otherwise specified the following checklists and forms shall be used to facilitate the efficient transfer of data for inquiries, proposals and contracts. The purchaser may submit the required data to the vendor in a form other than that indicated herein. However, the alternative forms shall include at least all the information specified in Annex C and Annex E.

- **11.1.2** Other or additional documentation requirements for proposals and contracts shall be specified in the inquiry of the purchaser.

11.1.3 The minimum information to be furnished by the seal vendor is specified in the Data Requirement Forms and shall be sent to the address or addresses noted on the enquiry or order.

11.1.4 The following information shall be identified on proposal letters, contract cover sheets, and on mechanical seal datasheets for Category 1 and Category 2 installations. Category 3 installations shall

have the information on cover letters, mechanical seal datasheets, arrangement drawings, and on installation, operation, and maintenance manuals:

- a) the purchaser or user's corporate name;
- b) the job or project reference;
- c) the equipment item number and service name;
- d) the inquiry or purchase order number;
- e) any other identification specified in the inquiry or purchase order; and
- f) the manufacturer's identifying proposal reference, shop order number, serial number, or other reference required to uniquely identify return correspondence.

11.1.5 Unless otherwise specified at the inquiry stage, the installation, operation, and maintenance manuals shall be in English. A copy shall be included with the supplied seal and auxiliary system. It shall provide sufficient instructions and a cross-referenced list of all drawings and bills of materials to enable the purchaser to correctly install, operate, and maintain all of the equipment covered by the purchase order.

11.1.6 A copy of the seal drawing has to be put into the box in which the seal is shipped and another copy has to be put into the bag that also contains the metal plugs for the gland plate (see 6.1.2.18). The bag then has to be put into the box with the seal.

11.2 Data Requirement Forms

The information to be furnished for inquiries, proposals and contracts is described in the Data Requirements Forms (see Annex E). These forms specify the required data for Category 1, Category 2, and Category 3 and on which document it shall be placed. The Data Requirement Forms also specify which party is responsible for the provision of which data.

11.3 Datasheet

Completion of the datasheets (Annex C) is the joint responsibility of the purchaser and the vendor. The purchaser may submit the datasheets to the vendor in a form other than that indicated herein. However, the alternative datasheets shall include at least all the information provided in Annex C. Mechanical seals can be described in a general manner by using mechanical seal codes such as those given in Annex D.

NOTE This information is the basis for the selection, the specification and the purchasing agreement.

11.4 Inspector Checklist

This list can be used to check the compliance and completeness of the delivered seals and seal auxiliary systems according to this standard.

Annex A (informative)

Recommended Seal Selection Procedure

A.1 Assumptions and Instructions

A.1.1 Application Range

This seal selection procedure provides a recommended seal type, arrangement, piping plan and barrier/buffer fluid given the intended service condition, provided the conditions meet the seal operating envelope of Category 1 seals, Category 2 seals, or Category 3 seals.

The fluids covered by this selection process include:

- a) water;
- b) sour water (containing hydrogen sulfide H₂S);
- c) caustics;
- d) amines;
- e) some acids; and
- f) most hydrocarbons.

A.1.2 Additional Engineering Required

This is a recommended procedure only. It is the responsibility of the purchaser or seal vendor using this procedure to ensure that the selected seal and auxiliaries are suitable for the intended service condition. The use of other selection criteria and more detailed engineering review is specifically recommended for the following service conditions:

- a) pressures or temperatures outside the ranges defined in Section 4 of this standard;
- b) installations into seal chambers not included in Section 6 of this standard;
- c) seal types and arrangements not listed in this standard, e.g. coaxial seals;
- d) surface speed above 23 m/s (4500 ft/min);
- e) highly corrosive fluids for which the materials specified in this standard are not suitable;
- f) fluids with absolute vapor pressures in excess of 3.4 MPa (34 bar) (493 psi);
- g) unstable liquid properties, for example multiphase or non-Newtonian fluids, etc.;
- h) high solids concentration;
- i) shaft diameters above 110 mm (4.3 in.) or below 20 mm (0.75 in.);
- j) high viscosity or pour point above or within 20 °C (36 °F) of minimum ambient temperature; and

- k) fluids with special and/or unusual properties such as pharmaceuticals, liquid oxygen, hydrofluoric acid, food grade materials, and other specialty liquids.

A.1.3 Seal Leakage

There is always a mass flow rate across the face of a mechanical seal, so all seals “leak” to some extent. Leakage can occur regardless of seal category, type or arrangement; however, with Arrangement 2 and Arrangement 3 seals, the leaked fluid could be buffer or barrier fluid instead of process fluid. See F.1.1 for more detail.

A.1.4 Instructions and Seal Selection Sheets

To use these seal selection sheets, begin on Table A.1 (Sheet 1) and consult the appropriate sheet according to the relevant service condition and fluid. Where alternative seal types are listed, they should be considered an acceptable equivalent to the default seal shown.

RECOMMENDED SEAL SELECTION PROCEDURE SHEET 1 OF 10

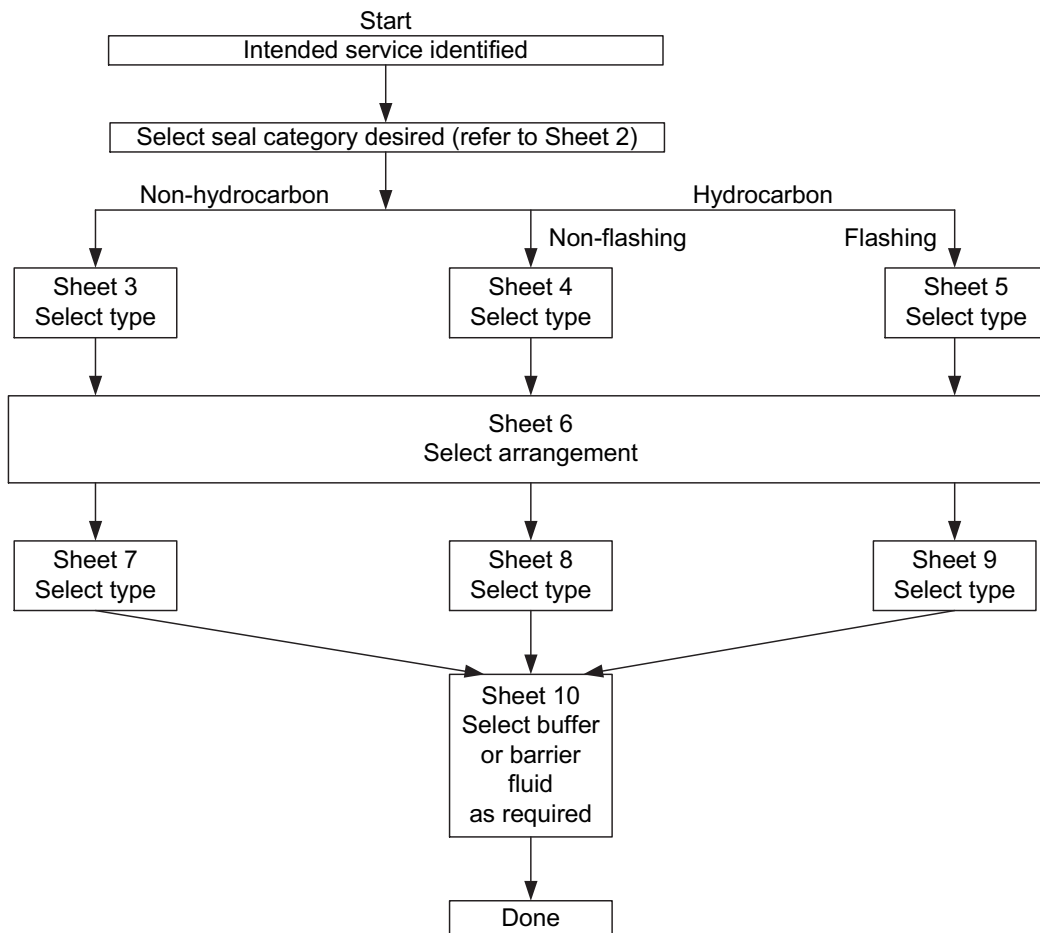

**RECOMMENDED SEAL SELECTION PROCEDURE
SEAL CATEGORY, TYPE, AND ARRANGEMENT SUMMARY
SHEET 2 OF 10**

Seal category shall be Category 1, Category 2, or Category 3 as specified.

The major features of each category are summarized below. Options, where they exist for each feature, are listed in the text as “if specified.” Subsection numbers in parentheses indicate where the requirements are specified.

	Category 1	Category 2	Category 3
Seal chamber size (4.1.2)	ASME B73.1 or ASME B73.2	API 610	API 610
Seal chamber temperature range (4.1.2)	−40 °C to 260 °C (−40 °F to 500 °F)	−40 °C to 400 °C (−40 °F to 750 °F)	
Maximum seal chamber pressure, gauge (4.1.2)	2.0 MPa (300 psi)	4.0 MPa (600 psi)	
Face materials (6.1.6.2)	carbon/graphite vs sintered silicon carbide	carbon/graphite vs reaction-bonded silicon carbide	
Distributed inlet flush requirements, Arrangements 1 and 2 with rotating flexible elements	If required by 6.1.2.14 or if specified (6.2.1.2.1)	Required. (6.2.2.2.1)	Required (6.2.3.2)
Gland plate metal-to-metal contact requirement	Required (6.1.2.28)	Required inside and outside of the bolt circle diameter (6.1.2.28)	
Cartridge seal shaft size increments required	None	10 mm increments. (6.2.2.3.1)	
Throttle bushing design requirement for Arrangement 1 seals (7.1.2.1)	Fixed carbon Floating carbon option (7.1.2.2)	Floating carbon	Floating carbon
Dual-seal circulation device head flow curve provided	If specified (7.1.2.8)		Required (7.1.2.8)
Scope of vendor qualification test	Test as Category 1 unless all the following have been tested to Category 2 or 3: a) core seal components b) adaptive hardware c) seal type d) configuration faces (1.3.5)	Test as Category 1 unless all the following have been tested to Category 3: a) core seal components b) adaptive hardware c) seal type d) configuration faces (1.3.5)	Test as Category 3, entire seal assembly as a unit (1.3.5)
Proposal data requirements	Minimal (Annex E)		Rigorous, including qualification test results (Annex E)
Contract data requirements	Minimal (Annex E)		Rigorous (Annex E)

SHEET 2 OF 10 (continued)

Seal type shall be Type A, Type B, or Type C as specified.

The major features of each type are summarized below. Options, where they exist for each feature, are listed in the text as “if specified.” Subsection numbers in parentheses indicate where the requirements are specified.

Feature	Type A	Type B	Type C
Standard temperature application range (4.1.3)	–40 °C to 176 °C (–40 °F to 350 °F)		–40 °C to 400 °C (–40 °F to 750 °F)
Hydraulic balance requirement (4.1.3 and 6.1.1.7)	Balanced (e.g. hydraulic balance less than 1)		
Mounting requirement (4.1.3)	Inside the seal chamber		
Cartridge requirement (4.1.3 and 6.1.1.1)	Cartridge design		
Flexible element style (4.1.3)	Pusher (e.g. sliding elastomer)	Nonpusher (e.g. bellows)	
Flexible element orientation (4.1.3)	Rotating Stationary option (6.1.1.2)		Stationary Rotating option (6.1.1.3)
Bellows material (6.1.6.6)	Not applicable	Alloy C-276	Alloy 718
Spring type (4.1.3)	Multiple-coil springs Single-spring option (6.1.5.1)	Single bellows	
Maximum surface speed for rotating element application (6.1.1.5)	23 m/s (4500 ft/min)		Not applicable
Secondary sealing element material (4.1.3)	Elastomer		Flexible graphite

SHEET 2 OF 10 (continued)

Seal arrangement shall be Arrangement 1, Arrangement 2, or Arrangement 3 as specified.

The major features of each arrangement are summarized below. Options, where they exist for each feature, are listed in the text as “if specified.” Section numbers in parentheses indicate where the requirements are specified.

Feature	Arrangement 1	Arrangement 2	Arrangement 3
Number of core seal components per cartridge, see Annex I	One (3.2 and 4.1.4)	Two (3.3 and 4.1.4)	Two (3.4 and 4.1.4)
Uses a barrier or buffer fluid (4.1.4)	No	Sometimes, but not required. Liquid or gas buffer permitted.	Yes, barrier fluid required, liquid or gas permitted
Allows noncontacting (wet or dry) seals (4.1.4)	No	Yes, Figure 4	Yes, Figure 6
Throttle bushing requirement. (7.1.2.1)	Category 1: Fixed carbon Category 2: Floating carbon Category 3: Floating carbon	If specified	
Arrangement 2 containment seal chamber bushing requirement	Not applicable	Required with dry-running containment seal regardless of inner seal design (7.2.4.1 and 7.2.5.1)	Not applicable
Maximum buffer/barrier fluid temperature rise	Not applicable	8 °C (15 °F) aqueous or diesel, 16 °C (30 °F) mineral oils (7.2.3.1)	8 °C (15 °F) aqueous or diesel, 16 °C (30 °F) mineral oils (7.3.3.1)
Seal chamber pressure/flush design requirement (6.1.2.14)	Seal chamber pressure 0.35 MPa (3.5 bar) (50 psi) above fluid vapor pressure		None
Minimum operating seal chamber pressure requirement (6.1.2.14)	0.035 MPa (0.35 bar) (5 psi) above atmospheric pressure		None
Minimum gland plate connection sizes and orientation	See Table 1		
Minimum barrier/barrier fluid liquid reservoir	Not applicable	12 liters (3 U.S. gal) for shaft diameter 60 mm (2.5 in.) and smaller barrier; otherwise 20 liters (5 U.S. gal) (8.3.6.2.5)	
Test requirements	(10.3.2.2) Annex I		

RECOMMENDED SEAL TYPE SELECTION PROCEDURE
SHEET 3 OF 10
Nonhydrocarbon services

Fluids	Operating Conditions, Recommended Seal Types, and Special Features								
	1	2	3	4	5	6	7	8	
	Water			Sour water		Caustic, amines crystallize		Acids ^a H ₂ SO ₄ , H ₃ PO ₄	
Pumping temperature.	°C (°F)	<80 (<180)		>80 (>180)		<80 (<180)			
Seal chamber gauge pressure, Category 1 seals	MPa (bar) (psi)	<2.0 (<20) (<300)	Not applicable	<2.0 (<20) (<300)		Not applicable	<2.0 (<20) (<300)	Not applicable	<2.0 (<20) (<300)
Seal chamber gauge pressure, Category 2 and 3 seals	MPa (bar) (psi)	<2.0 (<20) (<300)	2.0 to 4.0 (20 to 40) (300 to 600)		<2.0 (<20) (<300)	2.0 to 4.0 (20 to 40) (300 to 600)		<2.0 (<20) (<300)	2.0 to 4.0 (20 to 40) (300 to 600)
Default seal type	Type A								
Options if specified		Type B Type C	ES ^b	ES ^b	Type B Type C	ES ^b	Type B Type C	ES ^b	Type B Type C
Required special features		Not applicable		Circulating device	Perfluoroelastomer		Amine-resistant perfluoroelastomer		Perfluoro-elastomer and single spring for Type A seals
Special features for contaminants ^c									
Abrasive particulates	Hardface versus hardface								
This selection procedure chooses seal designs consistent with the default positions throughout this standard. Listed options meeting the requirements of this standard might perform equally well.									
^a Up to 20 % H ₂ SO ₄ at 25 °C (77° F) only. Up to 20 % H ₃ PO ₄ at 80 °C (176 °F) only. All other acids, including hydrofluoric, fuming nitric, and hydrochloric acids, require special engineering agreed between purchaser and vendor. ^b Totally engineered sealing system. Consult vendor to ensure special design considerations are accounted for. ^c Special features listed apply only in mixtures having pH between 4 and 11. ^d NaOH applications require self-sintered SiC.									

**RECOMMENDED SEAL TYPE SELECTION PROCEDURE
SHEET 4 OF 10
Nonflashing hydrocarbons**

Fluids		Operating Conditions, Recommended Seal Types, and Special Features								
		1	2	3	4	5	6	7	8	
Pumping temp	°C (°F)	-40 to -5 (-40 to 23)		-5 to 176 (23 to 348.8)		176 to 260 (348.8 to 500)		260 to 400 (500 to 700)		
Seal chamber gauge pressure, Category 1 seals	MPa (bar) (psi)	<2.0 (<20) (<300)	Not applicable	<2.0 (<20) (<300)	Not applicable	<2.0 (<20) (<300)	Not applicable			
Seal chamber gauge pressure, Category 2 and 3 seals	MPa (bar) (psi)	<2.0 (<20) (<300)	2.0 to 4.0 (20 to 40) (300 to 600)	<2.0 (<20) (<300)	2.0 to 4.0 (20 to 40) (300 to 600)	<2.0 (<20) (<300)	2.0 to 4.0 (20 to 40) (300 to 600)	<2.0 (<20) (<300)	2.0 to 4.0 (20 to 40) (300 to 600)	
Standard seal type		Type A				Type C	ES ^a	Type C	ES ^a	
Option if specified		Type B	ES ^{a b}	Type B	ES ^{a b}	ES ^a	Not applicable	ES ^a	Not applicable	
Option if specified		Type C	Not applicable	Type C	Not applicable					
Required special features		Nitrile O-rings		Not applicable						
Special features for contaminants^c										
Caustic		Not applicable		Perfluoroelastomer		Not applicable				
Abrasive particles		Hardface versus hardface								
Aromatics and/or H ₂ S		Not applicable		Perfluoroelastomer		Not applicable				
Amines		Not applicable		Amine-resistant Perfluoroelastomer		Not applicable				
This selection procedure chooses seal designs consistent with the default positions throughout this standard. Listed options meeting this standard might perform equally well.										
^a Totally engineered sealing system. Consult vendor to ensure special design considerations are accounted for. ^b Engineered (high-pressure) bellows. ^c Special features listed apply only in mixtures having pH between 4 and 11.										

RECOMMENDED SEAL TYPE SELECTION PROCEDURE
SHEET 5 OF 10
Flashing hydrocarbons

Fluids	Operating Conditions, Recommended Seal Types, and Special Features								
		1	2	3	4	5	6	7	8
Pumping temp	°C (°F)	-40 to -5 (-40 to 23)		-5 to 176 (23 to 348.8)		176 to 260 (348.8 to 500)		260 to 400 (500 to 700)	
Seal chamber gauge pressure, Category 1 seals	MPa (bar) (psi)	<2.0 (<20) (<300)	Not applicable	<2.0 (<20) (<300)	Not applicable	<2.0 (<20) (<300)	Not applicable		
Seal chamber gauge pressure, Category 2 and 3 seals	MPa (bar) (psi)	<2.0 (<20) (<300)	2.0 to 4.0 (20 to 40) (300 to 600)	<2.0 (<20) (<300)	2.0 to 4.0 (20 to 40) (300 to 600)	<2.0 (<20) (<300)	2.0 to 4.0 (20 to 40) (300 to 600)	<2.0 (<20) (<300)	2.0 to 4.0 (20 to 40) (300 to 600)
Standard seal type		Type A		Type A ^d		Type C	ES ^{a b}	Type C	ES ^{a b}
Option if specified		ES ^a	ES ^{a b}	ES ^a	ES ^{a b}	ES ^a	Not applicable	ES ^a	Not applicable
Required special features		Nitrile O-rings		Not applicable					
Special features for contaminants^c									
Caustic		Not applicable		Perfluoroelastomer		Not applicable			
Abrasive particles		Hardface versus hardface							
Aromatics and/or H ₂ S		Not applicable		Perfluoroelastomer		Not applicable			
Amines		Not applicable		Amine-resistant Perfluoroelastomer		Not applicable			
Ammonia		NH ₃ resistant carbon graphite							
This selection procedure chooses seal designs consistent with the default positions throughout this standard. Listed options meeting this standard might perform equally well.									
^a Totally engineered sealing system. Consult vendor to ensure special design considerations are accounted for. ^b Engineered (high-pressure) bellows. ^c Special features listed apply only in mixtures having pH between 4 and 11. ^d Requires special feature (circulating device) above 60 °C (140 °F), and special feature (perfluoroelastomer) if pumping temperature is above 176 °C (350 °F)									

RECOMMENDED SEAL ARRANGEMENT SELECTION PROCEDURE SHEET 6 OF 10

Considerations in the selection of a seal arrangement

Assume Arrangement 1 to begin



SHEET 6 OF 10 (continued)

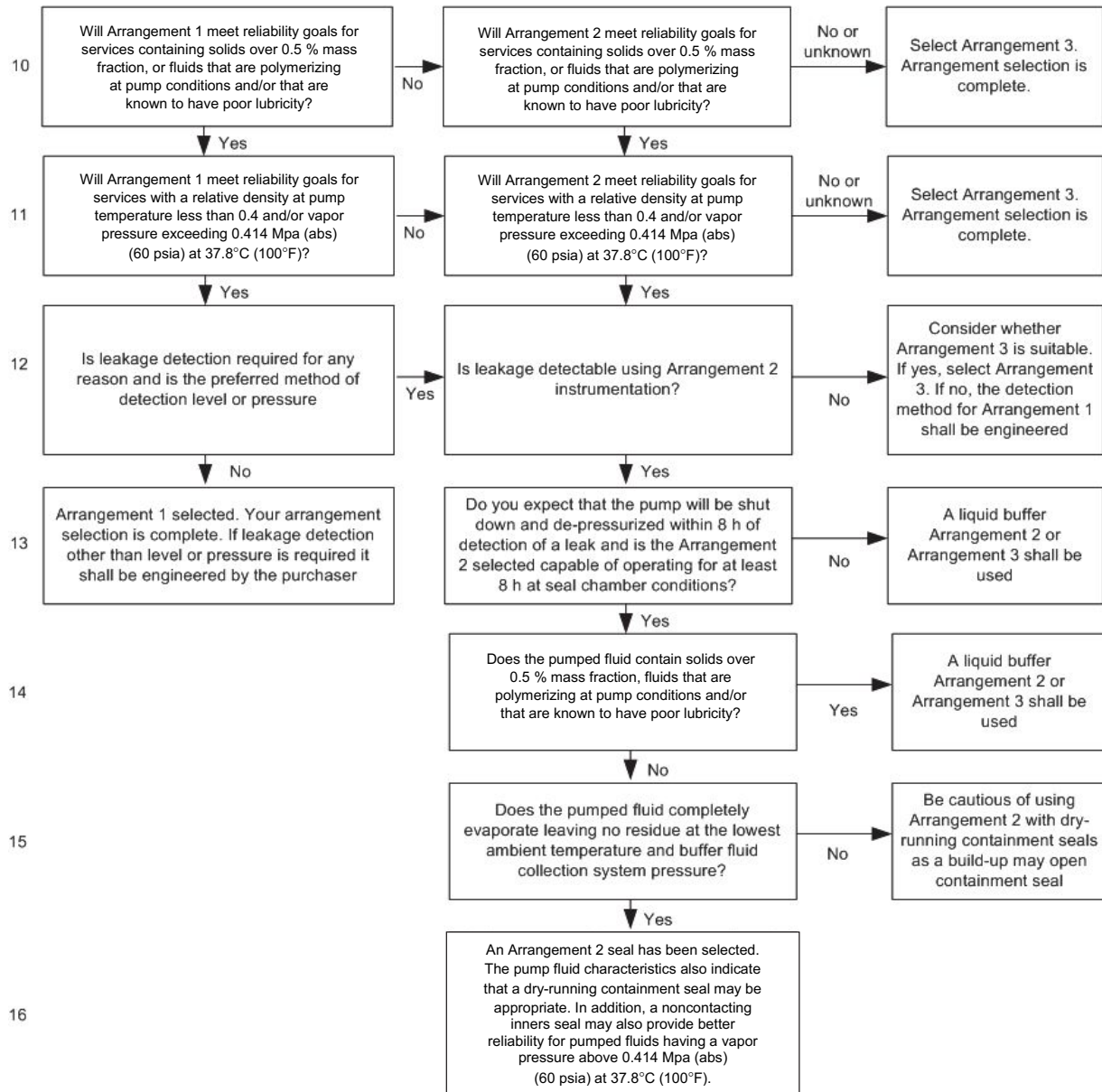

RECOMMENDED SEAL PIPING PLAN SELECTION PROCEDURE SHEET 8 OF 10 Nonflashing hydrocarbon

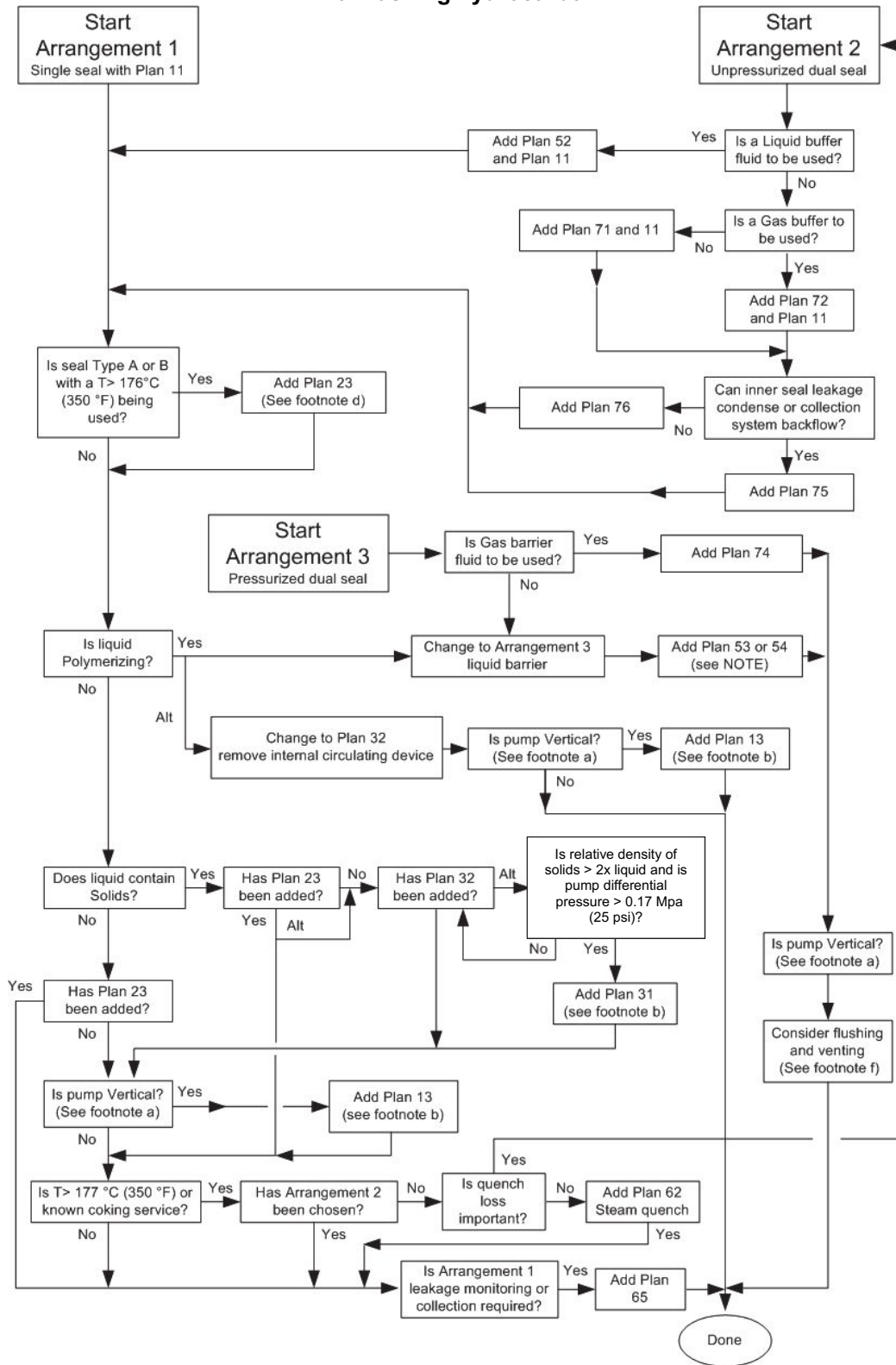

RECOMMENDED SEAL PIPING PLAN SELECTION PROCEDURE
SHEET 9 OF 10
Flashing hydrocarbon

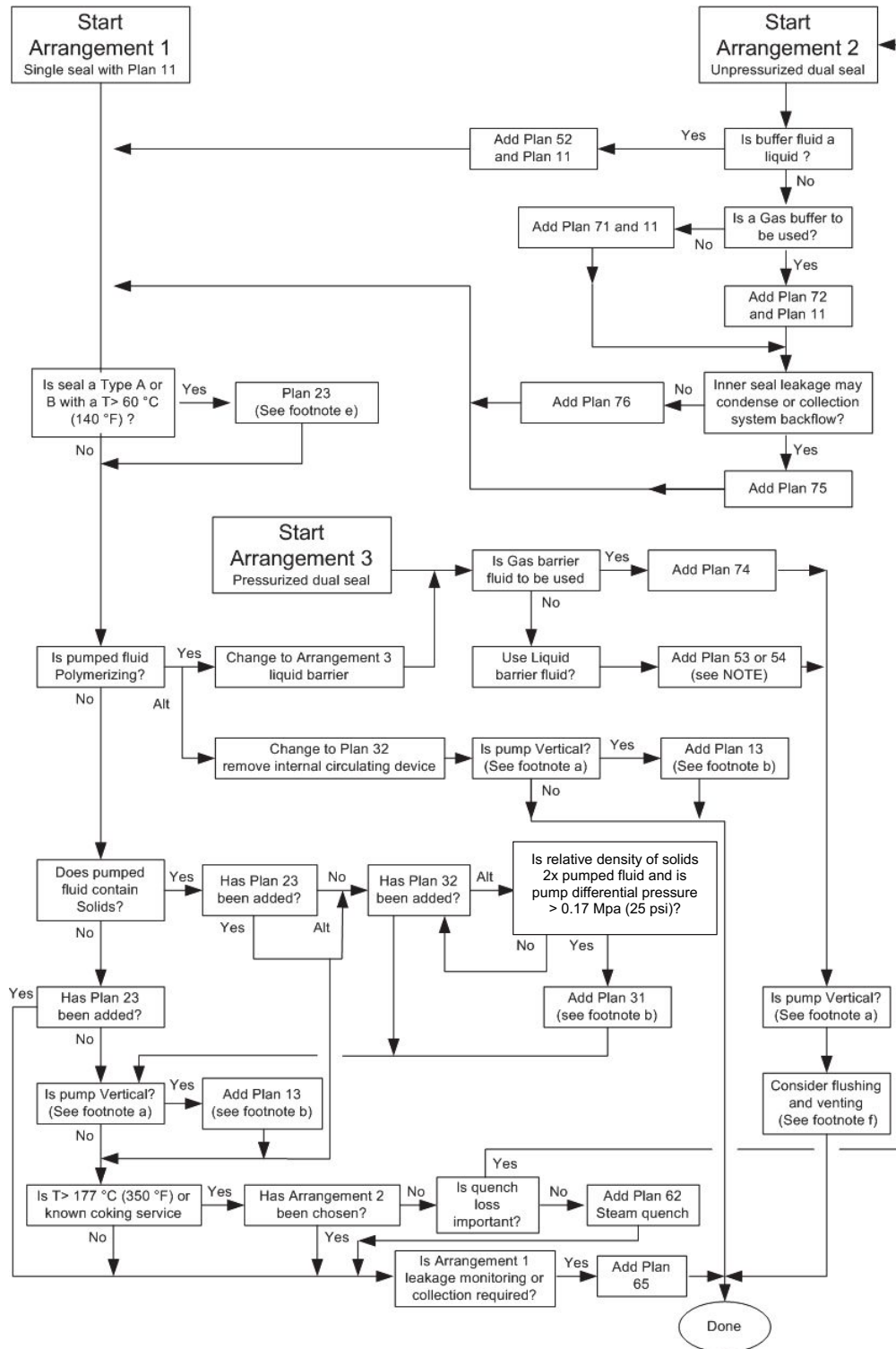

NOTE See F.2.7 and Annex G for guidance on selecting Piping Plan 53A, 53B, or 53C.

Footnotes for Sheets 7, 8, and 9

a The user should evaluate whether to add Piping Plan 13 or not, considering such factors as the inclusion of a bleed bushing, contamination of the seal chamber with pumped fluid, the need for venting of the seal chamber, and the need to reduce seal chamber pressure due to static or dynamic pressure rating of the seal versus the expected static and dynamic seal chamber pressure.

b When a Piping Plan 13 alone is selected, if there is insufficient pressure difference between the seal chamber and the pump suction to ensure the required flush flow, then select a Piping Plan 14. For services with suspended solids where Piping Plan 31, 32, or 41 is required and vertical pumps are selected, then a bleed bushing should be provided instead of a Piping Plan 13. The objective is to avoid excessive head bushing wear and the unnecessary introduction of suspended solids into the seal chamber.

Discussion: An example is charge service in a Gas Oil Separation Plant: Piping Plan 32 is used because of suspended solids and it makes little sense to apply Piping Plan 13 (or 14) that requires the process flow with suspended solids to pass the head bushing below the seal chamber. Suspended solids in the process fluid passing the head bushing will increase the bushing wear and clearance reducing the effectiveness of the bushing. Solids introduced into the seal chamber can collect on seal parts causing premature failure.

c Cooling is needed because of low lubricity at elevated temperature. The recommended piping plan is Piping Plan 23 because field experience has shown that this plan is much less prone to plugging than Piping Plan 21 because of recirculation of cooler fluid from the seal chamber. However, the user may wish to reconsider using Piping Plan 21 because of the added seal complexity imposed by Piping Plan 23 (size and cost), and other factors such as the use of an air cooler for Piping Plan 21 in areas where water cannot be used or is not available. (An air cooler works better on Piping Plan 21 because of the higher temperature difference between the pumped fluid and the cooling medium.) The user may also wish to consider the use of Piping Plan 32 if a suitable fluid is available, especially if the fluid is normally injected into the process anyway (such as make-up water). See the flush descriptions later in this annex for additional detail.

d Cooling is needed because of temperature limits of the standard secondary elastomers for Arrangement 1 and possibly for Arrangement 2 (consult the seal vendor). Consideration may be given to changing to perfluoroelastomer if cooling is not possible. The recommended piping plan is Piping Plan 23 because field experience has shown that this plan is much less prone to plugging than Piping Plan 21 because of recirculation of cooler fluid from the seal chamber. However, the user may wish to reconsider using Piping Plan 21 because of the added seal complexity imposed by Piping Plan 23 (size and cost) and other factors such as the use of an air cooler for Piping Plan 21 in areas where water cannot be used or is not available. (An air cooler works better on Piping Plan 21 because of the higher temperature difference between the pumped fluid and the cooling medium.) The user may also wish to consider the use of Plan 32 if a suitable fluid is available, especially if the fluid is normally injected into the process anyway (such as make-up water). See the flush descriptions later in this annex for additional detail.

e Cooling is recommended to suppress flashing within the seal faces. Because of cooling-water temperatures, this is usually only effective above the temperature shown. Below this temperature, or as an alternative to adding cooling, the user may wish to use experience at their site or other alternatives such as high flushing rates, distributed flush systems, increased seal chamber pressure, or combinations thereof, to obtain satisfactory seal life. There may also be the opportunity to use Piping Plan 32 if suitable flush fluid is available or, if experience is available, a change to Arrangement 3 may be appropriate.

f Consider the need to add additional flushing to the process side of the inner seal. Flushing is sometimes needed for Arrangement 3 FB orientation to provide additional cooling, and Piping Plan 11 or Piping Plan 13 may be a suitable choice. Other services may require a Piping Plan 32 flush if the pumped fluid is extremely corrosive, aggressive, or solids laden. Consider the need for venting on vertical pumps. Special attention may be needed on Arrangement 3 NC configurations to ensure effective pump operation. Consult the pump vendor if the pump is vented through the seal chamber, and consider the effects listed in footnote a above.

RECOMMENDED SEAL ARRANGEMENT SELECTION PROCEDURE
SHEET 10 OF 10
Buffer/barrier fluid selection

The following should be considered when selecting a barrier/buffer fluid:

- a) compatibility of the fluid with the process fluid being sealed, so as not to react with or form gels or sludge if leaked into the process fluid or the process fluid into the barrier/buffer fluid;
- b) compatibility of the fluid with the metallurgy, elastomers, and other materials of the seal/flush system construction;
- c) compatibility of the fluid assuming it reaches the process fluid temperature (high or low).

On pressurized barrier fluid systems where the method of pressurization is a gas barrier, special attention should be given to the application conditions and barrier fluid selection. Gas solubility in a barrier fluid increases with increasing pressure and decreases with increasing barrier fluid temperature. As pressure is relieved or temperatures rise, gas is released from solution and can result in foaming and loss of circulation of the barrier fluid. This problem is normally seen where higher viscosity barrier fluids, such as lubricating oils, are used at pressures above 1.0 MPa (10 bar) (150 psi).

The viscosity of the barrier/buffer fluid should be checked over the entire operating-temperature range, with special attention being given to start-up conditions. The viscosity should be less than 500 mm²/s (500 cSt) at the minimum temperature to which it is exposed.

The following barrier fluid performance facts should be considered.

- a) Hydrocarbon barrier/buffer fluids having a viscosity below 100 mm²/s (100 cSt) at operating temperature are considered as acceptable and have performed satisfactorily.
- b) The most desirable viscosity for hydrocarbon barrier/buffer fluids is between 2 mm²/s (2 cSt) and 10 mm²/s (10 cSt) at operating temperature.
- c) For aqueous streams, mixtures of water and ethylene glycol or propylene glycol are usually adequate. Commercially available automotive antifreeze should never be used. The additives in antifreeze tend to plate out on seal parts and cause failure as a result of gel formation.
- d) The fluid should not freeze at the minimum ambient temperature at the site.

Fluid volatility and toxicity of the fluid shall be such that leakage to the atmosphere or disposal does not impose an environmental problem. The barrier/buffer fluid can be classified as hazardous, depending upon the local regulations at the pump site. A verification of the barrier/buffer fluid safety datasheet should be carried out to ensure that the leakage across the outer seal does not infringe local personnel occupational exposure limits. In addition:

- a) the fluid should have an initial boiling point at least 28 °C (50 °F) above the temperature to which it will be exposed;
- b) if oxygen is present the fluid should have a flash point higher than the service temperature;
- c) ethylene glycol can be considered a hazardous material and/or hazardous waste when used as a barrier fluid.

The fluid should be able to meet the minimum three-year (3-yr) continuous seal operation criteria without adverse deterioration. It should not form sludge, polymerize, or coke after extended use.

For hydrocarbon streams, mineral oil is known to degrade at temperatures greater than 70 °C (158 °F), however, paraffin-based high purity oils having little or no additive for wear/oxidation resistance, or synthetic-based oils have been used successfully.

Antiwear or oxidation-resistance additives in commercial turbine oils have been known to plate out on seal faces.

A.2 Tutorial Section

A.2.1 Seal Selection Justification

A.2.1.1 All seal selections by service were made with the following considerations in mind:

- a) to produce a reliable sealing system that has a high probability of operating for three (3) years of uninterrupted service, meeting or exceeding environmental emission regulations;
- b) to ensure personnel and plant safety in hazardous services; and
- c) to minimize spare parts inventory required for insurance stock.

A.2.1.2 All selections were made using experience gained in engineering, purchasing, operating, retrofitting, and maintaining mechanical seals in various services and locations. The selections were made to ensure that the best seal for the service will be installed. This standard does not attempt to prevent the selection of other seals. However, if a seal not specified by this standard is chosen, special engineering is recommended for successful operation.

Any seal operating with a seal chamber gauge pressure above a gauge pressure of 2.0 MPa (20 bar) (300 psi) for Category 1 seals or a gauge pressure of 4.0 MPa (40 bar) (600 psi) for Category 2 and Category 3 seals requires special engineering. Any product temperature above 260 °C (500 °F) for Category 1 seals and above 400 °C (750 °F) for Category 2 and Category 3 seals also requires special engineering design considerations. Therefore, the selection categories are limited to the above pressures and temperatures for this standard.

A.2.1.3 The seal references in this standard are:

- a) Type A, pusher seal;
- b) Type B, bellows seal with elastomeric secondary seals; and
- c) Type C, bellows seal with flexible graphite secondary seal elements.

See Section 3, Section 4, and sheet 2 of this annex for further description.

NOTE Pressure levels listed apply to Category 1, Category 2, or Category 3 as noted on the applicable sheet.

A.2.2 Nonhydrocarbon Services—Sheet 3

A.2.2.1 Clean Water Below 80 °C (180 °F) and Below a Gauge Pressure of 2.0 MPa (20 bar) (300 psi)

The recommended seal is a Type A pusher with no special features required.

The recommended option is either a Type B or Type C metal bellows with no special features required.

A.2.2.2 Clean Water Below 80 °C (180 °F) and a Gauge Pressure of Between 2.0 MPa (20 bar) (300 psi) and 4.0 MPa (40 bar) (600 psi)

The recommended seal is a Type A pusher with no special features required.

Any seal other than a Type A should be specially engineered for high pressure. Seal manufacturers normally rate their metal bellows designs for gauge pressures of less than 2.0 MPa (20 bar) (300 psi). The seal manufacturer should be consulted for specific performance data above this pressure.

A.2.2.3 Water Above 80 °C (180 °F) and at a Gauge Pressure Below 4.0 MPa (40 bar) (600 psi)

The recommended seal is a Type A pusher with special features. The special features are a single-spring seal with an internal circulating device to circulate through a Piping Plan 23 closed-loop system. As shown on sheet 7, a Piping Plan 21 can also be used, especially if an air cooler is used. The alternative seal is a Type A recommended pusher with special features to include an internal circulating device to circulate through a Piping Plan 23 closed-loop system, and a close-clearance bushing in the bottom of the sealing chamber.

A Piping Plan 23 flushing arrangement is the most efficient way of providing a cool flush to the seal faces. Use of an internal circulating device to circulate the fluid through a closed-loop cooler allows the cooler to continuously cool a recirculated stream rather than a continuous (hot) stream from the discharge of the pump (Piping Plan 21). The cooler now has to cool only that fluid in the loop, and the duty cycle is much less severe than a Piping Plan 21.

A survey in one facility revealed that the average temperature of the inlet flush to the sealing chamber was 50 °C (122 °F). The average pumping temperature of the product was 219 °C (426 °F). The idle pump's average inlet temperature was 38 °C (100 °F). The idle pump relied only on the thermosyphon through the cooler to cool the fluid. The cooler should be mounted in accordance with this standard to ensure proper thermosyphoning.

A.2.2.4 Sour Water Below 80 °C (180 °F) Up to a Gauge Pressure of 4.0 MPa (40 bar) (600 psi)

The recommended seal is a Type A pusher with special features. The elastomers should be changed to FFKM to resist the H₂S, as H₂S is generally the agent that sours water.

The recommended option up to a gauge pressure of 2.0 MPa (20 bar) (300 psi) is either a Type B or Type C seal with the special feature of FFKM for the Type B.

The use of a Type B or Type C seal above a gauge pressure of 2.0 MPa (20 bar) (300 psi) requires special engineering for the high pressure.

This selection is made to maximize the standardization process, as the Type A seal is recommended for all pressure ranges. Sour water can become flashing as the temperature and H₂S content increase.

A.2.2.5 Caustic, Amines, and Other Crystallizing Fluids Below 80 °C (180 °F) and Below a Gauge Pressure of 4.0 MPa (40 bar) (600 psi)

The recommended seal is a Type A pusher with the special features of FFKM.

The recommended alternative, up to a gauge pressure of 2.0 MPa (20 bar) (300 psi) is a Type B metal bellows seal with FFKM.

The use of Type C seals up to a gauge pressure of 2.0 MPa (20 bar) (300 psi) with flexible graphite secondary seals should be specially engineered, as graphite is not recommended for some caustic applications.

For gauge pressures above 2.0 MPa (20 bar) (300 psi) but below 4.0 MPa (40 bar) (600 psi), the use of Type B and Type C metal bellows seals require special engineering for the high pressure.

Any application in a crystallizing fluid requires the use of a Piping Plan 62 quench or a Piping Plan 32 flush to keep crystals from forming on the atmospheric side of the seal. Most facilities prohibit a quench from seals unless totally contained. A Piping Plan 32 flush arrangement is generally not acceptable, as it dilutes the product and is sometimes expensive to operate. In these conditions an Arrangement 2 dual seal (un-pressurized buffer) should be considered, using clean water (or other compatible fluid) as a buffer to keep the crystals in solution. The same special features apply to both the dual seal and the single seals.

A.2.2.6 Acids: Sulphuric, Hydrochloric, Phosphoric Acids at Less Than 80 °C (180 °F) and Below a Gauge Pressure of 2.0 MPa (20 bar) (300 psi)

The recommended seal is a Type A pusher with the special features of a single coil-spring.

The recommended option is a Type B or Type C seal using flexible graphite as a secondary in the Type C seal.

Because of the thin cross-section of multiple-coil springs and bellows plates, the most corrosion-resistant material for the application should be selected.

Hydrofluoric, fuming nitric, and other acids are not covered in this selection. Specially engineered designs agreed between the owner and the seal manufacturer should be used.

Seals for use with acids at temperatures over 80 °C (180 °F) require special engineering.

Seals for use with acids at a gauge pressure above 2.0 MPa (20 bar) (300 psi) require special engineering.

A.2.3 Nonflashing Hydrocarbons [Absolute Vapor Pressure Less Than 0.1 MPa (1 bar) (14.7 psi) at Pumping Temperature]—Sheet 4

A.2.3.1 From -40 °C to -5 °C (-40 °F to 20 °F) and Below a Gauge Pressure of 4.0 MPa (40 bar) (600 psi)

The recommended seal is a Type A pusher with the special feature of NBR elastomers for low-temperature service. The NBR shall also be compatible with the pumped fluid.

The recommended alternative up to a gauge pressure of 2.0 MPa (20 bar) (300 psi) is either a Type B with the special feature of NBR elastomers or a Type C seal with flexible graphite secondary seals.

For gauge pressures over 2.0 MPa (20 bar) (300 psi), seal Type B and Type C require engineered bellows designed for the high pressure.

The special feature of NBR elastomers is due to the low temperature. The standard FKM is rated at -17.7 °C (0 °F), but, for the applications of this standard, FKM should not be used below -5 °C (20 °F).

A.2.3.2 From -5 °C to 176 °C (20 °F to 350 °F) and Gauge Pressures Below 4.0 MPa (40 bar) (600 psi)

The recommended seal is a Type A pusher with no special features required. (Check elastomer compatibility charts for pumped fluid.)

The recommended option for gauge pressures up to 2.0 MPa (20 bar) (300 psi) is a Type B or Type C nonpusher. The Type C seal should be used with flexible graphite secondary seals.

The recommended alternative for gauge pressures above 2.0 MPa (20 bar) (300 psi) is a Type B or Type C with engineered bellows for the high pressure.

The recommended pusher seal elastomer is FKM, which is rated at 204 °C (400 °F). A pumping temperature of 176 °C (350 °F) is realistic for FKM, as the face friction will generate additional heat and raise the temperature the elastomer shall endure.

A.2.3.3 From 176 °C to 260 °C (350 °F to 500 °F) and Below a Gauge Pressure of 2.0 MPa (20 bar) (300 psi)

The recommended seal is a Type C stationary nonpusher metal bellows seal using flexible graphite for secondary seals.

The Type C seal is recommended because of the temperature range, which is the range where coking generally occurs. The stationary bellows design easily accepts a steam baffle for anticoking protection, whereas a rotating bellows does not.

The recommended alternative is a Type A pusher with special features including an internal circulating device and FFKM, circulating through a Piping Plan 23 closed-loop system in accordance with the piping plan selection diagram.

A Type A seal with an internal circulating device and a Piping Plan 23 closed-loop system maintains the product temperature below the range where coking occurs.

A.2.3.4 From 176 °C to 260 °C (350 °F to 500 °F) and from a Gauge Pressure of 2.0 MPa (20 bar) (300 psi) to 4.0 MPa (40 bar) (600 psi)

A totally engineered sealing system is required for hot high-pressure services.

A.2.3.5 From 260 °C to 400 °C (500 °F to 750 °F) and Below a Gauge Pressure of 2.0 MPa (20 bar) (300 psi)

The Type C seal is recommended because of the temperature range, which is the range where coking generally occurs. The stationary bellows design easily accepts a steam baffle for anticoking protection, whereas a rotating bellows does not.

The recommended alternative is a totally engineered sealing system.

A.2.3.6 From 260 °C to 400 °C (500 °F to 750 °F) and from a Gauge Pressure of 2.0 MPa (20 bar) (300 psi) to 4.0 MPa (40 bar) (600 psi)

The only acceptable option is a totally engineered sealing system.

A.2.4 Flashing Hydrocarbons (Vapor Pressure Above 0.1 MPa (1 bar) (14.7 psi) at Pumping Temperature)—Sheet 5

A.2.4.1 From -40 °C to -5 °C (-40 °F to 20 °F) and a Gauge Pressure Below 4.0 MPa (40 bar) (600 psi)

The recommended seal is a Type A pusher with the special feature of an NBR elastomer. It should be ensured that NBR is compatible with the pumped fluid.

The recommended alternative is an engineered sealing system with an engineered metal bellows for the flashing service.

Metal bellows seals in flashing service are prone to fatigue failure, induced by “stick-slip” if marginal vapor suppression occurs. If metal bellows are desired, the seal should be a totally engineered sealing system with special attention to vapor suppression under all operating conditions of the pump, including, but not limited to, start-up, shutdown and plant upsets.

A.2.4.2 From –5 °C to 176 °C (20 °F to 350 °F) and a Gauge Pressure Below 4.0 MPa (40 bar) (600 psi)

The recommended seal is a Type A pusher with special features to maintain adequate vapor suppression. If the temperature is above 60 °C (140 °F), an internal circulating device and a Piping Plan 23 closed-loop system should be considered as an alternative to help reduce flashing at the seal face. If the temperature is above 176 °C (350 °F), FFKM should be used.

The recommended alternative is a totally engineered sealing system with an engineered metal bellows.

Vapor suppression by cooling is always preferred over pressurization. Therefore, a Type A seal with internal circulating device and a Piping Plan 23 closed-loop system is selected if the temperature is above 60 °C (140 °F). The 60 °C (140 °F) limit is based on the cooling-water temperature in the hot months, where little cooling of a product below 60 °C (140 °F) will occur. Various locations can require a higher or lower limit based on the maximum cooling-water temperature in that specific location.

A.2.4.3 From 176 °C to 400 °C (350 °F to 750 °F) and Below a Gauge Pressure of 2.0 MPa (20 bar) (300 psi)

The recommended seal is a Type C seal. The recommended alternative is a totally engineered sealing system.

A.2.4.4 Above 176 °C (350 °F) and a Gauge Pressure from 2.0 MPa (20 bar) (300 psi) to 4.0 MPa (40 bar) (600 psi)

The seal should be a totally engineered sealing system.

A.3 Tutorial Seal Selection—Sheet 6

A.3.1 Sheet 6 is intended as a guide to some of the aspects that might be considered in the selection of a seal arrangement. The user should evaluate the cost benefits and risk associated with any selection.

A.3.2 Question 1 is whether there are any regulations effective at the site of the equipment that require specific hardware. This hardware could include low-emission single seal or dual seals. The question is intended to alert the user so that he/she can investigate the possibility that specific designs might be required.

A.3.3 Question 2 alerts the user to examine the pumped stream to determine if any owner or operator standards exist that would dictate or help define the required arrangement from the owner or operator. These standards might deem the stream hazardous and require specific methods of control or limits of exposure on emissions, even if local regulations do not. Seal designs should then employ the required hardware or be designed to meet the required emission limit.

A.3.4 Question 3 addresses selection of arrangement for acids. If the stream is not acid, the user can skip from question 3 to question 5.

A.3.5 Question 4 selects the arrangement for an acid stream as either a single seal or a pressurized dual seal. Unpressurized dual seals are not recommended because of the potential for buildup of acid in the buffer system or containment seal chamber.

A.3.6 Question 5 addresses materials that can pose a personnel hazard, such as rich (in H₂S) amine streams, to highlight the need for control beyond a single seal without external flush. The highlight is needed because specifications often overlook the need for added control measures on this type of stream.

A.3.7 Question 6 is similar to question 5, except it addresses streams for which an Arrangement 1 seal will not meet safety requirements of the owner concerning a potential vapor cloud or fire risk.

A.3.8 Question 7 addresses the need for additional sealing control on those streams that will not meet local emission requirements with an Arrangement 1 seal. Arrangement 2 or Arrangement 3 is chosen as needed instead.

A.3.9 Question 8 alerts the user to the fact that in certain countries, Arrangement 1 seals in specific services are required to be monitored (or “sniffed”) for emissions. If the user wishes to perform this monitoring then Arrangement 1 is suitable. However, the option is given to change the arrangement and possibly avoid monitoring.

A.3.10 Question 9 addresses reliability considerations for hot services. Experience has shown that Arrangement 2 or Arrangement 3 can provide better reliability.

A.3.11 Question 10 addresses reliability considerations for polymerizing agents, solids, and low-lubricity fluids out of the seal faces in order to help meet the goal of three-year (3-yr) uninterrupted service life.

A.3.12 Experience has shown Arrangement 1 and Arrangement 2 used in very light fluids often cannot meet the goal of a three-year (3-yr) service. Special sealing arrangements involving the use of noncontacting inner seals in an Arrangement 2 have been known to provide very reliable service in fluids such as methane, ammonia, propane, and other hydrocarbon mixtures of high vapor pressure.

A.3.13 Question 12 is intended to alert the user to the possible need for provision of an alarm for leakage. An arrangement other than Arrangement 1 is generally needed if leakage shall be detected.

A.3.14 Question 13 determines how the user intends to use the containment feature of an unpressurized dual seal. Because of heat generation and face load, dry containment seals can have limited life at full seal chamber conditions.

A.3.15 This step changes to an Arrangement 3 or recommends a liquid buffer if the pumpage contains solids or polymerizing agents. These contaminants can reduce the reliability of dry containment seals.

A.3.16 An Arrangement 2 seal has been selected and further guidance is provided on the possible use of noncontacting inner seals.

A.4 Alternative Seal Arrangement Selection Method Using Material Safety Datasheet Information

A.4.1 The selection procedure proposed below selects the applicable seal arrangement, based on the sealed fluid hazard code according to the 2007 second revised edition of the United Nations Globally Harmonized System of Classification and Labeling of Chemicals (GHS) and the European Union Regulation (EC) 1272/2008 on the classification, labeling and packaging of substances and mixtures. This procedure may also be applicable using the Dangerous Substances Directive 67/548/EEC risk phrase classification of the pumped fluid to be sealed.

A.4.2 The seal type should be selected according to the selection logic included in Annex A sheets 3, 4, and 5 and the applicable sections of this standard.

A.4.3 The piping plan should be selected according to the selection logic included in Annex A sheets 7, 8, and 9 and the applicable sections of this standard.

A.4.4 To use this selection method the purchaser shall generate and supply the vendor with the Material Safety Datasheet (MSDS) for the pumped fluid and any buffer or barrier fluid. There can be more than one MSDS for variations in pumped fluid. For this procedure, the areas of most interest in the MSDS are as follows.

- *Chapter 3*—Composition/component data, especially constituent components contributing to hazards.
- *Chapter 8*—Exposure controls/personal protection, especially occupational exposure limits.
- *Chapter 15*—Regulatory data especially the applicable H statement codes or R phrases.

A.4.5 All possible combinations of R-phrases or H-statements have been grouped into four groups and are listed in Table A.1 and Table A.2.

A.4.6 Using the data from Chapter 15 of the MSDS, the pumped fluid R phrases or H statements should be examined individually to establish the applicable group and the most severe (lowest group number) should be used for the selection procedure.

A.4.7 If the applicable R-phrases or H-statement codes lead to a selection of Group III or Group IV but Chapter 8 of the MSDS recommends or imposes exposure limits then the pumped liquid should be considered Group II.

A.4.8 Entering the Seal Selection logic chart (Figure A.1) at the top left-hand corner the seal arrangement selection can be simply established. The Group II seal arrangement selection chart (Figure A.2) should be used for all Group II liquids and should be applied for each of the constituent components contributing to the hazard that are listed in Chapter 3 of the MSDS.

The x-axis of this chart represents the mass fraction (as a percentage) of the component that contributes to the hazard (e.g. 1 % benzene in gasoline). This data can be found in Chapter 3 of the MSDS. The sloping lines represent the threshold limit value for an eight hour (8 h) time weighted average (TLV-TWA) exposure limit for that component (e.g. 3.25 mg/m³ for benzene). The intersection of the mass fraction component line and the TLV-TWA exposure limit line can be read on the y-axis as the seal arrangement required.

A.4.9 If the fraction percentage of the component is given as volume percent instead of mass percent the conversion is as follows.

$$\omega_{AB} = V\%_{AB} \left(\frac{\rho_A}{\rho_B} \right) \quad (\text{A.1})$$

where

- ω_{AB} is the mass percentage of component A in mixture B;
- $V\%_{AB}$ is the volume percentage of component A in mixture B;
- ρ_A is the density (specific gravity) of fluid A;
- ρ_B is the density (specific gravity) of fluid B.

A.4.10 If required, conversions from parts per million (volume) (ppmv) to milligrams per cubic meter (mg/m³) at different temperatures can be made using the conversion charts in Figure A.3 and Figure A.4.

A.4.11 Buffer or barrier fluids should also be tested using this procedure to ensure that they satisfy the requirements for an Arrangement 1 or 1+ seal.

Table A.1—R-phrase Grouping Table

R-phrase	Group	R-phrase	Group	R-phrase	Group
R 1	I	R 30	III	R 48/20/22	III
R 2	III	R 31	III	R 48/21	III
R 3	I	R 32	II	R 48/21/22	III
R 4	I	R 33	III	R 48/22	III
R 5	III	R 34	III	R 48/23	II
R 6	I	R 35	III	R 48/23/24	II
R 7	III	R 36	IV	R 48/23/24/25	II
R 8	III	R 36/37	IV	R 48/23/25	II
R 9	III	R 36/37/38	IV	R 48/24	III
R 10	IV	R 36/38	IV	R 48/24/25	III
R 11	III	R 37	IV	R 48/25	III
R 12	III	R 37/38	IV	R 49 Cat 1	II
R 13	n/a	R 38	IV	R 49 Cat 2	III
R 14	I	R 39	III	R 49 Cat 3	III
R 14/15	I	R 39/23	II	R 50	IV
R 15	III	R 39/23/24	II	R 50/53	IV
R 15/29	II	R 39/23/24/25	II	R 51	IV
R 16	III	R 39/23/25	II	R 51/53	IV
R 17	I	R 39/24	III	R 52	IV
R 18	III	R 39/24/25	III	R 52/53	IV
R 19	III	R 39/25	III	R 53	IV
R 20	IV	R 39/26	II	R 54	IV
R 20/21	IV	R 39/26/27	II	R 55	IV
R 20/21/22	IV	R 39/26/27/28	II	R 56	IV
R 20/22	IV	R 39/26/28	II	R 57	IV
R 21	IV	R 39/27	III	R 58	IV
R 21/22	IV	R 39/27/28	III	R 59	IV
R 22	IV	R 39/28	III	R 60	II
R 23	III	R 40	III	R 61	II
R 23/24	III	R 41	III	R 62	III
R 23/24/25	III	R 42	III	R 63	III
R 23/25	III	R 42/43	III	R 64	III
R 24	IV	R 43	IV	R 65	IV
R 24/25	IV	R 44	III	R 66	IV
R 25	IV	R 45 Cat1	II	R 67	IV
R 26	II	R 45 Cat 2	III	R 68	IV
R 26/27	II	R 45 Cat 3	III	R 68/20	III
R 26/27/28	II	R 46	II	R 68/20/21	III
R 26/28	II	R 47	II	R 68/20/21/22	III
R 27	III	R 48	III	R 68/20/22	III
R 27/28	III	R 48/20	III	R 68/21	IV
R 28	III	R 48/20/21	III	R 68/21/22	IV
R 29	III	R 48/20/21/22	III	R 68/22	IV

Table A.2—H Statement Grouping Table

H Statement	Group	H Statement	Group	H Statement	Group
EUH001	I	H242 ^a	III	H332	IV
EUH006	I	H250	I	H333	IV
EUH014	I	H251	I	H334	III
EUH018	III	H252	I	H335	IV
EUH019	III	H260	III	H336	IV
EUH029	III	H261	III	H340	II
EUH031	III	H270	III	H341	II
EUH032	II	H271	III	H350	II
EUH044	III	H272	III	H350i	II
EUH059	IV	H280	n/a ^b	H351	II
EUH066	IV	H281	n/a ^b	H360D	II
EUH070	IV	H290	n/a ^b	H360Df	II
EUH071	II	H300	III	H360F	II
H200	I	H301	IV	H360FD	II
H201	I	H302	IV	H360Fd	II
H202	I	H303	IV	H361d	III
H203	I	H304	IV	H361f	III
H204	III	H305	IV	H361fd	III
H205	III	H310	II	H362	III
H220	III	H311	IV	H370	II
H221	III	H312	IV	H371	III
H222	III	H313	IV	H372	II
H223	III	H314	III	H373	III
H224	III	H315	IV	H400	IV
H225	III	H316	IV	H401	IV
H226	IV	H317	IV	H402	IV
H227	IV	H318	III	H410	IV
H228	n/a ^b	H319	IV	H411	IV
H240	I	H320	IV	H412	IV
H241	I	H330	II	H413	IV
H242	III	H331	III		
^a Self-reacting liquid. ^b Not applicable, refers to solids and gases.					

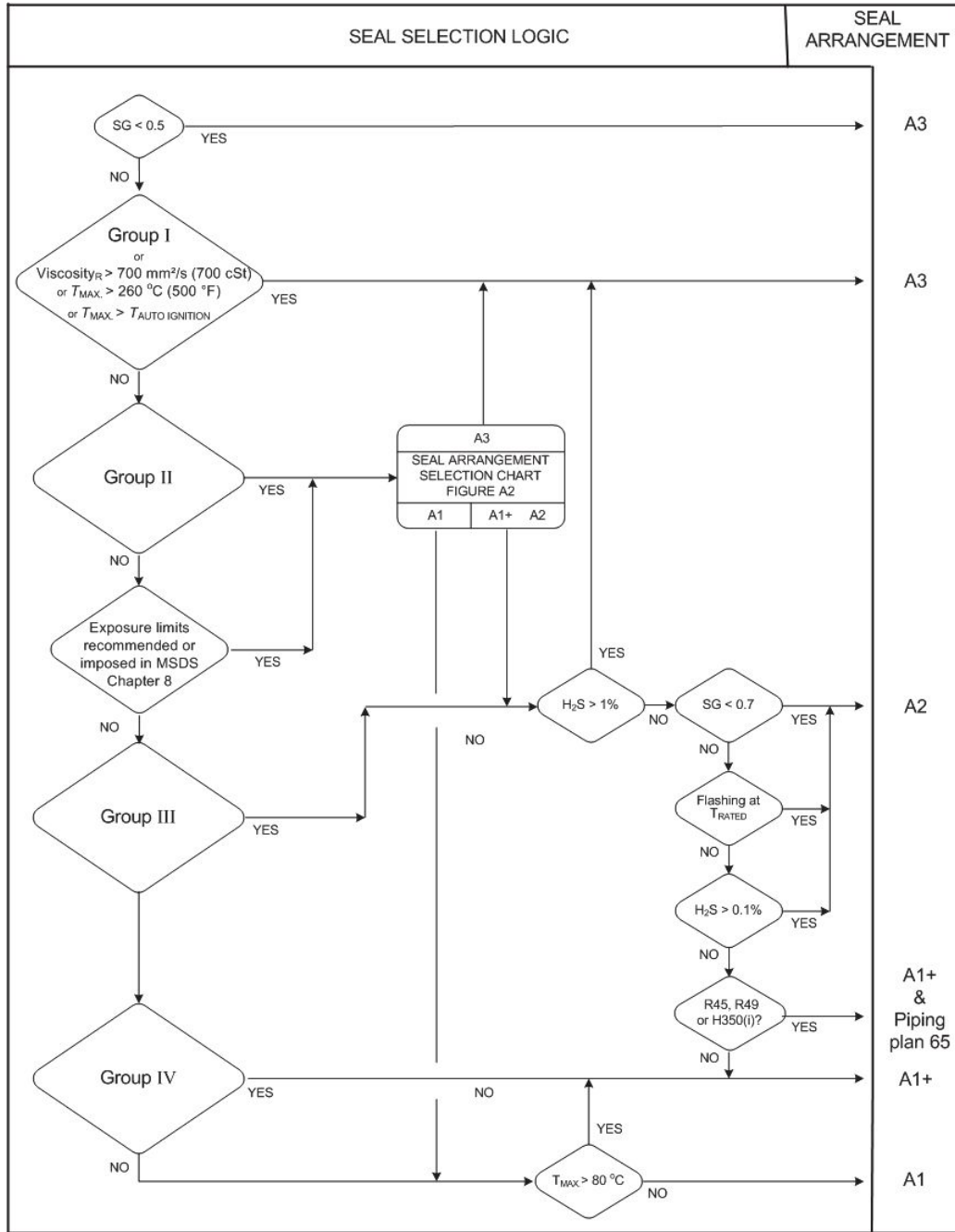

Seal type (A, B, or C) should be in accordance with Annex A Sheets 3, 4, and 5.

Piping Plan should be in accordance with Annex A Sheets 7, 8, and 9.

Key

A1+ Arrangement 1 seal with floating carbon bushing in accordance with 7.1.2.2

T temperature of pumped fluid, expressed in Celsius (°C) [Fahrenheit (°F)]

V_R rated viscosity, expressed in (millimeters per square millimeter) per second m/mm²/s [centistokes (cSt)]

Figure A.1—Seal Selection Logic

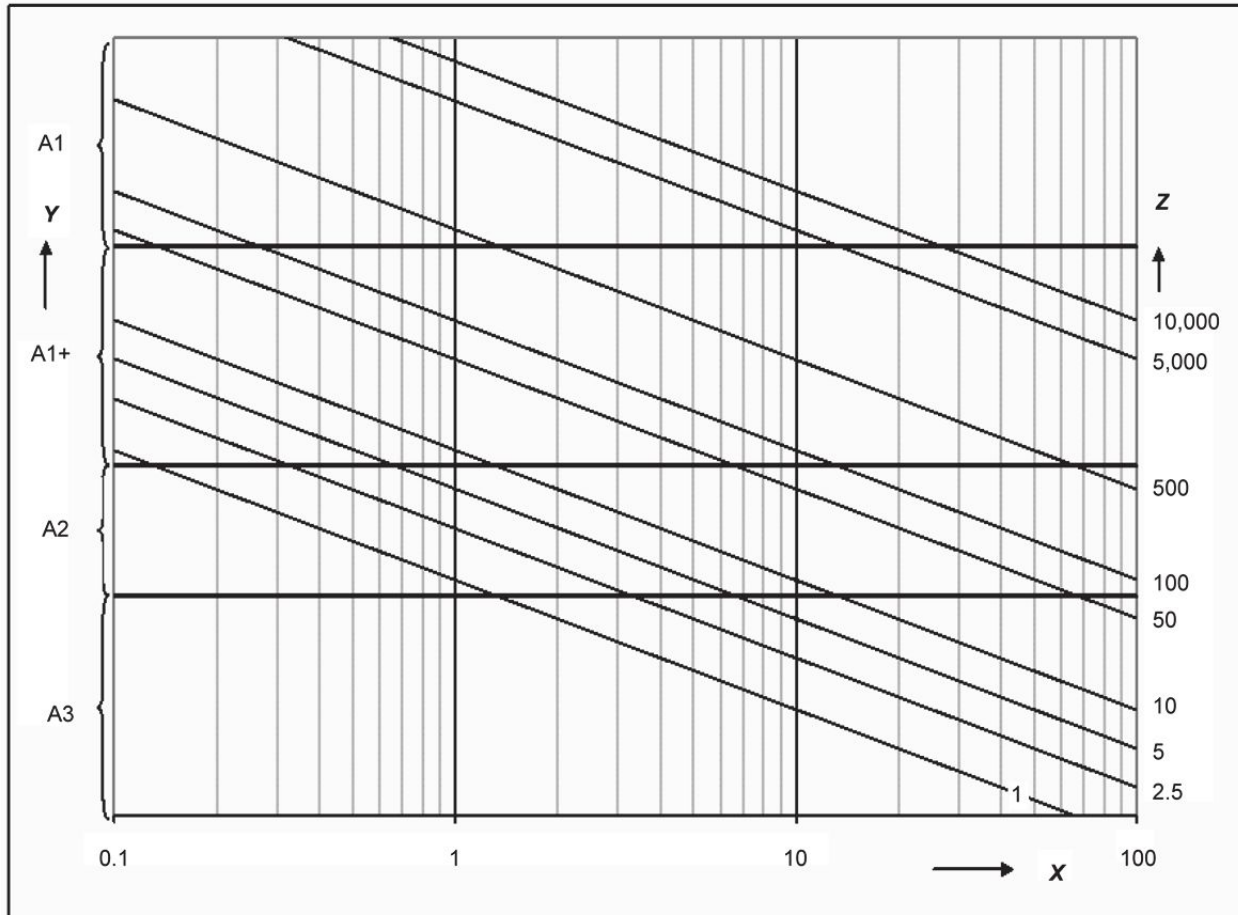
**Key**

X mass fraction (as a percentage) of component contributing to hazard

Y selected seal arrangement

Z threshold limit value for an 8 h time weighted average (TLV-TWA) of the component in mg/m³

NOTE If $Z/(14,965 \times X) < 0.05$, "A3." If $Z/(14,965 \times X) < 0.5$, "A2." If $Z/(14,965 \times X) < 25$, "A1+," "A1."

Figure A.2—Group II Seal Arrangement Selection Chart

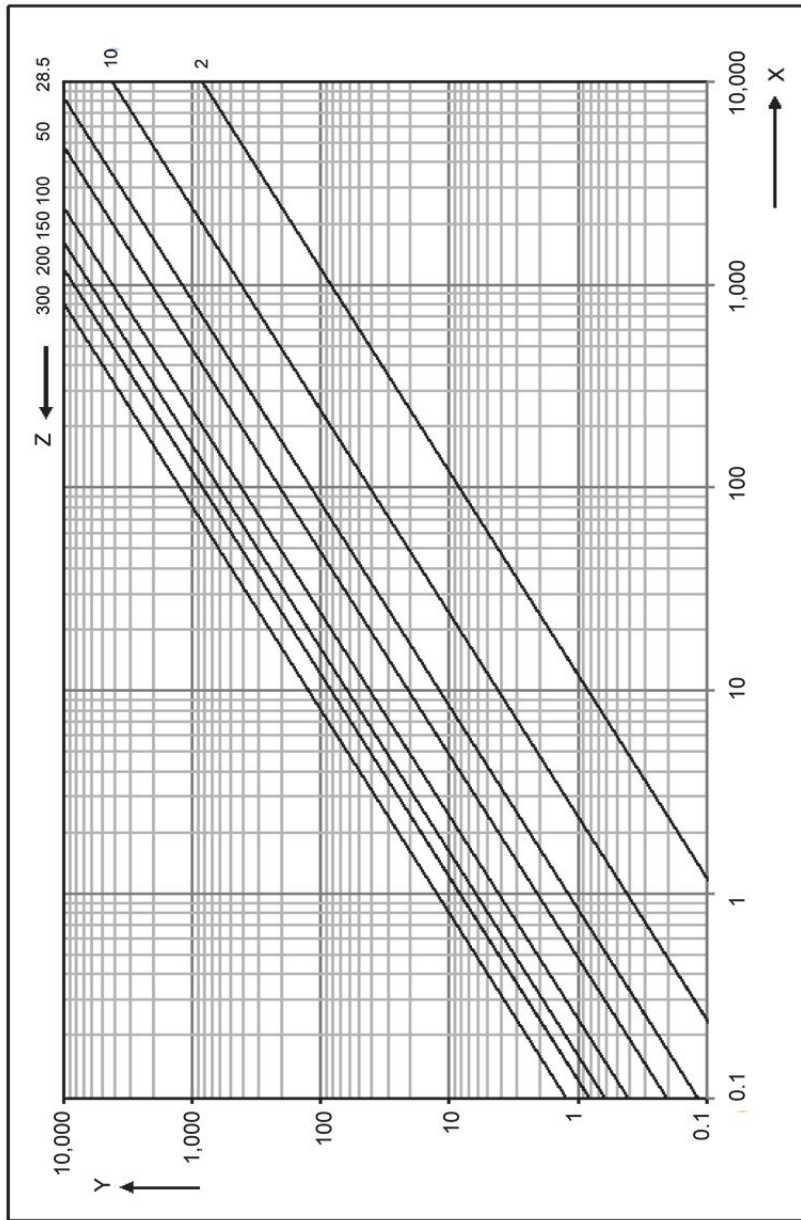

Key

- X ppmv exposure limit for contributing component (TLV-TWA)
- Y mg/m^3 exposure limit for contributing component (TLV-TWA)
- Z molecular weight of component contributing to hazard
- Y $X \times Z/24.45$

Figure A.3—Conversion of mg/m^3 to ppmv at 25 °C (77 °F) and Atmospheric Pressure

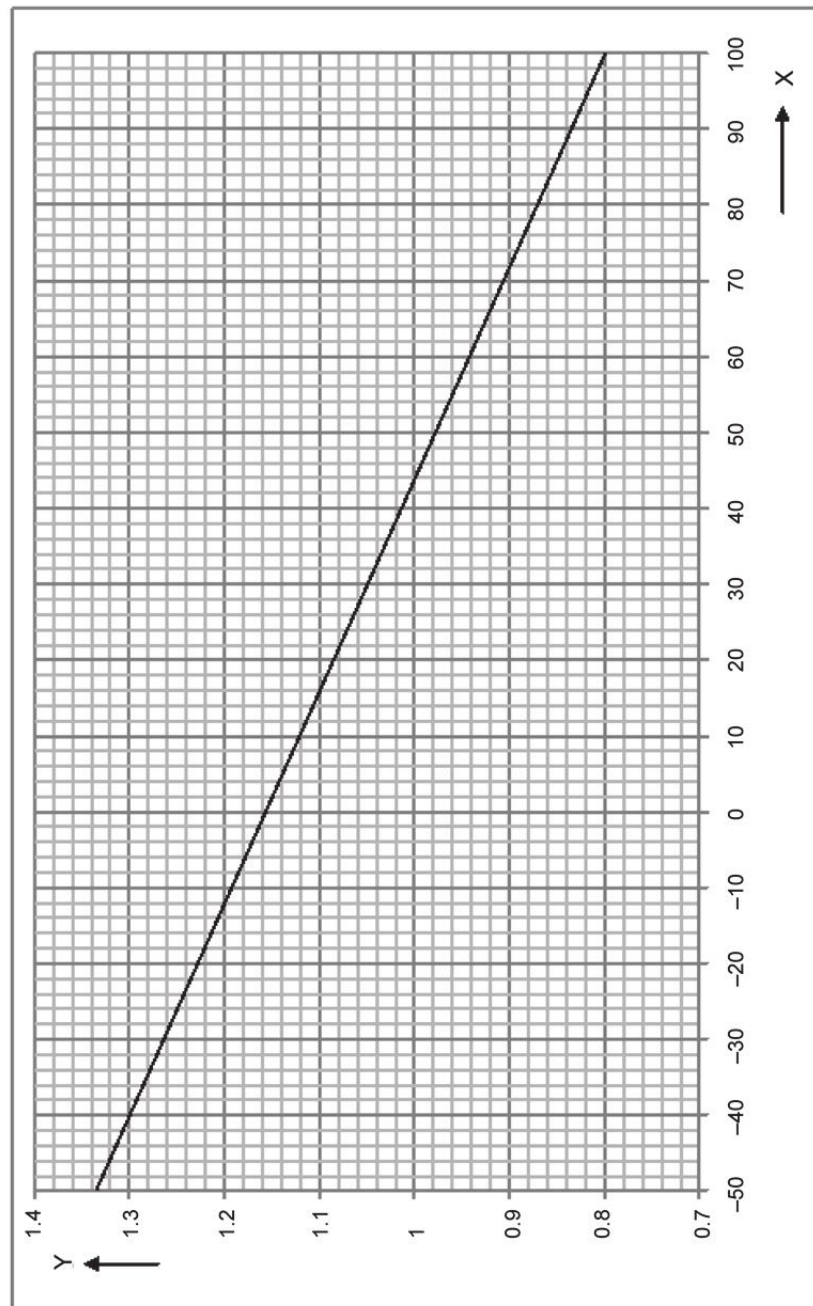
**Key**

- X ambient temperature, °C
- Y correction factor (multiply result of Figure A.3 by)
- Y $298.15/273.15 + X$

Figure A.4—Temperature Correction Factor for Figure A.3

Annex B (informative)

Typical Materials and Material Specifications for Seal Chamber and Mechanical Seal Components

B.1 Materials Standards

Table B.1 and Table B.2 may be used for guidance regarding materials specifications. If this table is used, it should not be assumed that the material specifications are acceptable without taking full account of the service in which they will be applied. Table B.1 lists corresponding international materials, which may be acceptable. These materials represent family/type and grade only. The final required condition or hardness level (where appropriate) is not specified. These materials might not be interchangeable for all applications.

Table B.1—Materials Standards

Material Class	Applic- ations	Inter- national ISO	USA		Europe			Japan
			ASTM	UNS ^a	EN ^b	Grade	Material No.	JIS
Cast iron	Pressure castings	185/Gr. 250	A278/A278M Class 30	F12401	EN 1561	EN-GJL-250	JL 1040	G 5501, FC 250
	General castings	185/Gr. 300	A48/A48M Class 25/30/40	F11701/ F12101	EN 1561	EN-GJL-250 EN-GJL-300	JL 1040 JL 1050	G 5501, FC 250/300
Carbon steel	Pressure castings	4991 C23 45 AH	A216/A216M Gr WCB	J03002	EN 10213	GP 240 GH	1.0619	G 5151, CI SCPH 2
	Wrought/ forgings	683-18-C25	A266 Class 4	K03506	EN 10222-2	P 280 GH	1.0426	G 3202, CI SFVC 2A
	Bar stock: pressure	683-18-C25	A696 Gr B40	G10200	EN 10273	P 295 GH	1.0481	G 4051, CI S25C
	Bar stock: general	683-18-C45e	A576 Gr 1045	G10450	EN 10083-2	C 45	1.0503	G 4051, CI S45C
	Bolts and studs	2604-2-F31	A193/A193M Gr B7	G41400	EN 10269	42 Cr Mo 4	1.7225	G 4107, Class 2, SNB7
	Nuts	683-1-C45	A194/A194M Gr 2H	K04002	EN 10269	C 35 E	1.1181	G 4051, CI S45C
	Plate	9328-4, P 355 TN/ PL 355 TN	A516/A516M Gr 65/70	K02403/ K02700	EN 10028-3	P 355 N P 355 NL1	1.0562 1.0566	G 3106, Gr SM400B
	Pipe	9329-2 PH26	A106/A106M Gr B	K03006	EN 10208-1	L 245 GA	1.0459	G 3456, Gr. STPT 370 / 410
	Fittings	—	A105/A105M	K03504	—	—	—	G 4051, CI S25C G 3202, CI SFVC 2A, SFVC2B
4140 alloy steel	Bar stock	—	A434 Class BB A434 Class BC	G41400 ^c	EN 10083-1	42 Cr Mo 4	1.7225	G 4105, CI SCM 440
	Bolts and studs	2604-2-F31	A193/A193M Gr B7	G41400	EN 10269	42 Cr Mo 4	1.7225	G 4107, Class 2, SNB7
	Nuts	683-1C45	A194/A194M Gr 2H	K04002	EN 10269	C 45 E	1.1191	G 4051, CI S45C

Table B.1—Materials Standards (continued)

Material Class	Applic- ations	Inter- national ISO	USA		Europe			Japan
			ASTM	UNS ^a	EN ^b	Grade	Material No.	JIS
12 % Chrome steel	Pressure castings	—	A487/A487M Gr CA6NM	J91540	EN 10213	GX 4 Cr Ni 13-4	1.4317	G 5121, C1 SCS 6, SCS 6X
	General castings	—	A743/A743M Gr CA 15	J91150	EN 10283	GX 12 Cr 12	1.4011	G 5121, CI SCS 1, SCS 1X1
		—	A743/A743M Gr CA6NM	J91540	EN 10283	GX 4 Cr Ni 13-4	1.4317	G 5121, CI SCS 6, SCS 1X1
	Wrought/ forgings: pressure	683-13-3	A182/A182M Gr F6a CI 1 A182/A182M Gr F 6 NM	S41000	EN 10250-4 EN 10222-5	X12 Cr13	1.4006	G 3214, Gr. SUS 410-A G 3214, CI SUS F6 NM
				S41500		X 3 Cr Ni Mo 13-4-1	1.4313	
	Wrought/ forgings: general	683-13-2	A473 Type 410	S41000	EN 10088-3	X 12 Cr 13	1.4006	G 3214, Gr. SUS 410-A
	Bar stock: pressure	683-13-3	A479/A479M Type 410	S41000	EN 10272	X 12 Cr 13	1.4006	G 4303, Gr. SUS 410 or 403
	Bar stock: general	683-13-3	A276 Type 410	S41400	EN 10088-3	X 12 Cr 13	1.4006	G 4303, Gr. SUS 410 or 403
	Bar stock: forgings ^c	683-13-4	A276 Type 420 A473 Type 416 A582/A582M Type 416	S42000	EN 10088-3	X 20 Cr 13	1.4021	G 4303, Gr. SUS 420J1 or 420J2
				S41600 S41600		X 20 Cr S 13 X 20 Cr S 13	1.4005 1.4005	
	Bolts and studs ^d	3506-1, C4-70	A193/A193M Gr B6	S41000	EN 10269	X22CrMoV 12-1	1.4923	G 4303, Gr. SUS 410 or 403
Nuts ^d	3506-2, C4-70	A194/A194M Gr 6	S41000	EN 10269	X22CrMoV 12-1	1.4923	G 4303, Gr. SUS 410 or 403	
Plate	683-13-3	A240/A240M Type 410	S41000	EN 10088-2	X 12 Cr 13	1.4006	G 4304/4305 Gr. SUS 403 or 410	

Table B.1—Materials Standards (continued)

Material Class	Applications	International	USA		Europe			Japan
		ISO	ASTM	UNS ^a	EN ^b	Grade	Material No.	JIS
Austenitic stainless steel	Pressure castings	683-13-10	A351/A351M Gr CF3	J92500	BSI/BS/ EN 10213-4	GX2 Cr Ni 19-11	1.4309	G 5121, CI SCS 19A
		683-13-19	A351/A351M Gr CF3M	J92800	BSI/BS/ EN 10213-4	GX2 Cr Ni Mo 19-11-2	1.4409	G 5121, CI SCS 16A, SCS 16AX
	General castings	—	A743/A743M Gr CF3	J92500	EN 10283	GX2 Cr Ni 19-11	1.4309	G 5121, CI SCS 19A
		—	A743/A743M Gr CF3M	J92800	EN 10283	GX2 Cr Ni Mo 19-11-2	1.4409	G 5121, CI SCS 16A, SCS 16AX
	Wrought/ forgings	9327-5, XCrNi18-10	A182/A182M Gr F 304L	S30403	EN 10222-5	X2 Cr Ni 19-11	1.4306	G 3214, Gr. SUS F 304L
		9327-5, XCrNiMo17-12	A182/A182M Gr F 316L	S31603	EN 10222-5 EN 10250-4	X2 Cr Ni Mo 17-12-2	1.4404	G 4304/4305, Gr. SUS 304L/316L
	Bar stock ^e	9327-5 X2CrNi18-10	A479/A479M Type 304L	S30403	EN 10088-3	X2 Cr Ni 19-11	1.4306	G 4303, Gr. SUS 304L G 4303, Gr. SUS 316 L
			A479/A479M Type 316L	S31603	EN 10088-3	X2 Cr Ni Mo 17-12-2	1.4404	
		683-13-19	A276, grade 316L	S31635	EN 10088-3	X2 Cr Ni Mo Ti 17-12-2	1.4571	G 4303, Gr. SUS 316 Ti
	Plate	9328-5 X2CrNi- Mo17-12-2	A240/A240M Gr 304L / 316L	S30403 S31603	EN 10028-7 EN 10028-7	X2 Cr Ni 19-11 X2 Cr Ni Mo 17-12-2	1.4306 1.4404	G 4304/4305, Gr. SUS 304L/ 316L
			Pipe	683-13-10 683-13-19	A312/A312M Type 304L 316L	S30403 S31603	—	—
	Fittings	9327-5, X2CrNi18-10 9327-5, X2CrNiMo17-12	A182/A182M Gr F304L, Gr 316L	S30403 S31603	EN 10222-5	X2 Cr Ni 19-11 X2 Cr Ni Mo 17-12-2	1.4306 1.4404	G 3214, Gr. SUS F304L/F316L
	Bolts and studs	3506-1, A4-70	A193/A193M Gr B 8M	S31600	EN 10250-4	X5 Cr Ni Mo 17-12-2	1.4401	G 4303, Gr. SUS 316
	Nuts	3506-2, A4-70	A194/A194M Gr B 8M	S31600	EN 10250-4	X5 Cr Ni Mo 17-12-2	1.4401	G 4303, Gr. SUS 316

Table B.1—Materials Standards (continued)

Material Class	Applications	International ISO	USA		Europe			Japan
			ASTM	UNS ^a	EN ^b	Grade	Material No.	JIS
Duplex stainless steel	Pressure castings	—	A890/A890M Gr 1 B A995/A995M Gr 1 B	J93372	BSI/BS/ EN 10213-4	GX2 CrNiMoCuN- 25-6-3-3	1.4517	—
		—	A890/A890M Gr 3 A A995/A995M Gr 3 A	J93371 J93371	—	—	—	G 5121, Gr. SCS 11
		—	A890/A890M Gr 4 A A995/A995M Gr 4 A	J92205 J92205	BSI/BS/ EN 10213-4	GX2 CrNiMoCuN- 25-6-3-3	1.4517	G 5121, Gr. SCS 10
	Wrought / forgings	9327-5, X2CrNiMoN 22-5-3	A182/A182M Gr F 51	S31803	EN 10250-4 EN 10222-5	X2CrNiMoN- 22-5-3	1.4462	—
		—	A479/A479M	S32550	EN 10088-3	X2CrNiMoCuN-25-6-3	1.4507	—
	Bar stock	9327-5, X2CrNiMo N22-5-3	A276-S31803	S31803	EN 10088-3	X2CrNiMoN- 22-5-3	1.4462	B 2312/B 2316 Gr. SUS 329 J3L
	Plate	—	A240/A240M-S31803	S31803	EN 10028-7	X2CrNiMoN- 22-5-3	1.4462	G 4304/G 4305, Gr. SUS 329 J3L
	Pipe	—	A790/A790M-S31803	S31803	—	—	—	G 3459, Gr. SUS 329 J3LTP
	Fittings	9327-5, X2CrNiMo N22-5-3	A182/A182M Gr F 51	S31803	EN 10250-4 EN 10222-5	X2CrNiMoN- 22-5-3	1.4462	B 2312/B 2316 Gr. SUS 329 J3L
	Bolts and studs	—	A276-S31803	S31803	EN 10088-3	X2CrNiMoN- 22-5-3	1.4462	G 4303, Gr. SUS 329J3L
Nuts	—	A276-S31803	S31803	EN 10088-3	X2CrNiMoN- 22-5-3	1.4462	G 4303, Gr. SUS 329 J3L	

Table B.1—Materials Standards (continued)

Material Class	Applications	Inter-national	USA		Europe			Japan
		ISO	ASTM	UNS ^a	EN ^b	Grade	Material No.	JIS
Super duplex stainless steel ^f	Pressure castings	—						
		—	A890/A890M Gr 5A	J93404	BSI/BS/EN 10213-4	GX2CrNiMo N26-7-4	1.4469	—
		—	A890/A890M Gr 6A	J93380	—	—	—	—
	Wrought/forgings	—	A182/A182M Gr 55	S32750 S32760	EN 10250-4 EN 10088-3	X2CrNiMoCu-WN 25-7-4	1.4501	G 4303, Gr. SUS 329 J4L
	Bar stock	—	A276-S32760 A479/A479M-S32760	S32750 S32760	EN 10088-3	X2CrNiMoCu-WN 25-7-4	1.4501	G 4304/G 4305, Gr. SUS 329 J4L
	Plate	—	A240/A240M-S32760	S32750 S32760	EN 10028-7	X2CrNiMoCu-WN 25-7-4	1.4501	—
	Pipe	—	A790/A790M-S32760	S32750 S32760	—	—	—	G 3459, Gr. SUS 329 J4LTP
	Fittings	—	A182/A182M Gr F55	S32750 S32760	EN 10250-4 EN 10088-3	X2CrNiMoCu-WN 25-7-4	1.4501	B 2312/B 2316 Gr. SUS 329 J4L
	Bolts and studs	—	A276-S32760	S32750 S32760	EN 10088-3	X2CrNiMoCu-WN 25-7-4	1.4501	G 4303, Gr. SUS 329 J4L
	Nuts	—	A276-S32760	S32750 S32760	EN 10088-3	X2CrNiMoCu-WN 25-7-4	1.4501	G 4303, Gr. SUS 329 J4L
<p>^a UNS (unified numbering system) designation for chemistry only.</p> <p>^b Where EN standards do not yet exist, European national standards are available, e.g. AFNOR, BS, DIN, etc.</p> <p>^c Do not use for shafts in the hardened condition (over 302 HB).</p> <p>^d Special, normally use AISI 4140.</p> <p>^e For shafts, standard grades of austenitic stainless steel may be substituted in place of low carbon (L) grades.</p> <p>^f Super Duplex stainless steel classified with pitting resistance equivalent (PRE) number greater than or equal to 40. $PRE = wCr + 3.3[wMo + (0.5wW)] + 16wN$, where w is the percentage mass fraction of the element indicated by the subscript.</p>								

Table B.2—Miscellaneous Materials Specifications

Common Name	Composition Specification
Bronze	UNS C87200 (silicon-bronze), C90700 or C92200 (tin-bronze), C95200 (aluminium bronze) or C95800 (nickel- aluminium-bronze)
Low-carbon nickel-molybdenum-chromium alloy (Alloy C276)	ASTM B564, UNS N10276 (forgings) ASTM B574, UNS N10276 (bar and rod) ASTM B575, UNS N10276 (plate, sheet and strip) ASTM A494, Grade CW-2M (weldable cast)
Nickel-copper alloy (Alloy 400)	ASTM B564, UNS N04400 (forgings) ASTM B164, Class A, UNS N04400 (bar and rod) ASTM B127, UNS N04400 (plate, sheet and strip) ASTM A494, Grade M30C (weldable cast)
Ni-resist	ASTM A436, Type 1, 2, or 3, UNS F41000, F41002, and F41004 respectively (austenitic cast iron), ASTM A439, Type D2, UNS F43000 (austenitic ductile iron)
Precipitation hardening nickel alloy (Alloy 718)	ASTM B637, UNS N07718 (forgings and bar) ASTM B670, UNS N07718 (plate, sheet and strip)
Alloy 20	ASTM A744 Grade CN7M, UNS N08007 (casting) ASTM B473, UNS N08020 (bar)
Alloy 42	ASTM F30, UNS K94100 (bar)
Precipitation-hardening stainless steel	ASTM A564, Grade 630, UNS S 17400 or Grade 631, UNS 17700 (wrought) ASTM A747, Grade CB7Cu-1, UNS J92180 (cast)
Elastomer	ASTM Standard Practice D1418 NBR, ISO 1629, Acrylonitrile butadiene ASTM Standard Practice D1418 EPDM, ISO 1629, Ethylene-propylene-diene ASTM Standard Practice D1418 FKM, ISO 1629, Fluoroelastomer ASTM Standard Practice D1418 FFKM, ISO 1629, Perfluoroelastomer
Flexible graphite	ASTM F104 Type 51, exfoliated and recompressed graphite material used as static secondary seals.
Carbon graphite	Self-lubricating composite of carbon and graphite impregnated with metallic or nonmetallic materials depending on the application need.
Thermoplastic resin	Chemically resistant material such as polyetheretherketone (PEEK) with continuous carbon fiber wound (API 610 Composite 1), or chopped carbon fiber filled (API 610 Composite 2).

B.2 Seal Rings and Mating Rings

B.2.1 Typical Temperature Limits

Typical temperature limits for seal face materials are given in Table B.3

Table B.3—Typical Temperature Limits for Seal Face Materials

Face Material	Maximum Temperature ^a °C (°F)
Tungsten carbide	1100 (2012) ^b
Silicon carbide (sintered, SSiC)	1650 (3002) ^b
Silicon carbide (reaction bonded, RBSiC)	1400 (2552) ^b
Silicon carbide—Graphite loaded (sintered, SSiCG)	550 (1022) ^b
Silicon carbide—Graphite loaded (reaction bonded, RBSiCG)	550 (1022) ^b
Carbon-graphite:	
Resin impregnated	285 (550)
Antimony impregnated	500 (932) ^b
^a With the exception of SSiC, chemical compatibility of face materials can vary with temperature and environment. ^b The temperature limit and scope of this standard is 400 °C (750 °F). Application of this material at a higher temperature would constitute an engineered seal.	

B.2.2 Carbon-graphite

B.2.2.1 General

Carbon-graphite is one of the most widely used seal face materials. It is typically prepared from a mixture of noncrystalline carbon and highly crystalline graphite with a pitch binder that is carbonized at high temperatures. The resulting structure is then impregnated with a resin or metal to reduce the porosity, minimize permeability, and enhance mechanical and wear properties.

Carbon-graphite has excellent tribological qualities and good mechanical properties. Many grades, i.e. compositions, are available that are compatible with a wide range of temperatures and aggressive environments. Because of its low modulus of elasticity, compared with the metal carbides, carbon-graphite is more susceptible to bending or distortion under pressure. Although broadly chemically inert, carbon-graphite can be attacked by strong oxidizing fluids, such as nitric or sulphuric acids, particularly at high temperature. Special grades have been developed that stand up to these more corrosive environments. In addition, there are grades designed for dry-running applications, such as contacting containment seals that normally run at low differential pressure.

B.2.2.2 Resin Impregnated

While resin impregnated grades have the lower modulus of elasticity they are generally more corrosion resistant than the metal impregnated grades. Maximum temperature limits also are lower. Because of their wear resistance, compatibility with metal carbides, and general utility resin impregnated carbon-graphite is the most widely used material.

B.2.2.3 Metal Impregnated

Metal-filled carbons have a higher modulus of elasticity and temperature limits than resin-filled grades, but have less corrosion resistance. These metal-filled carbons are often used in high-pressure applications

and, depending on the metal, are useful in limited lubrication applications like flashing hydrocarbons. Antimony impregnated grades are one of the most widely applied metal impregnated carbon-graphite because of its superior blister resistance and temperature range.

B.2.2.4 Blister Resistance

Mechanically induced shear forces can produce blistering of the seal face. Blisters are irregularities on the seal surface that degrade performance resulting in higher leak rates and eventually failure of the seal. So it is essential that the carbon-graphite is resistant to blistering. While antimony impregnated grades have shown to be less susceptible to blistering, both resin and metal impregnated grades are available that offer improved blister resistance.

B.2.3 Silicon Carbide

B.2.3.1 General

Silicon carbide is widely used as a material for seal rings. Its primary advantages are high hardness, excellent corrosion resistance, high thermal conductivity, and low coefficient of friction against carbon-graphite. Silicon carbides can be classified according to composition and manufacturing process. In addition, within these classifications, there are various grades, grain structures, etc. As a result, the two classifications of silicon carbide have some variation in performance when used as a seal face material.

Although there are differences within the classifications of silicon carbide, there are general characteristics as well. Reaction-bonded silicon carbide is regarded as having a marginally lower coefficient of friction against carbon-graphite under certain conditions. It is less brittle and is not as hard as sintered silicon carbide. Although real, these differences are small. One substantial difference is in corrosion resistance. As a rough rule of thumb, reaction-bonded silicon carbide is recommended for service where the pH is between 4 and 11; outside this range, sintered silicon carbide should be used.

For mechanical seals, reaction-bonded silicon carbide and sintered silicon carbide are widely used. New compositions of silicon carbide are also used called silicon carbide graphite-loaded because they contain both silicon carbide and free graphite.

B.2.3.2 Reaction Bonded Silicon Carbide (RBSiC)

Reaction-bonded silicon carbide is manufactured by reacting silicon metal with carbon-graphite in a silicon carbide matrix. The resulting material contains free silicon metal usually in the range of 8 % to 12 %. The wear and lubricating characteristics of reaction bonded silicon carbide are the best of all hard face materials; therefore it is the preferred material for high pressures and speeds. It also has good chemical resistance; however, some chemicals will attack the free silicon within the structure. Examples include sodium hydroxide and other caustics, amines, hydrofluoric acid and phosphoric acid containing small amounts of hydrofluoric acid.

B.2.3.3 Sintered Silicon Carbide (SSiC)

Sintered silicon carbide, on the other hand, consists strictly of silicon carbide. It is produced from pure silicon carbide powder with nonoxide sintering aids and is a homogeneous form of silicon carbide that does not contain any free silicon. The absence of the free silicon makes sintered silicon carbide chemically inert in virtually all corrosive environments. It is the most resistant to chemically-aggressive fluids and can be used in virtually any fluid. However, it does not have the pressure velocity (PV) capabilities of the other type of silicon carbide, and being the most brittle material it tends to chip more easily.

B.2.3.4 Silicon Carbide–Graphite Loaded

Reaction bonded silicon carbide–graphite (RBSiCG) and sintered silicon carbide–graphite (SSiCG) are available. Methods to improve the dry running capability and PV limits of hard-versus-hard face

combinations, such as silicon carbide against silicon carbide, have gained considerable attention. New composites of silicon carbide and graphite and modified face surface designs have been introduced to reduce face lubrication sensitivity and improve PV limits. These composites contain both silicon carbide and free graphite ranging from a few percent up to fifty percent (50 %) graphite. The addition of graphite to the silicon carbide base reduces strength but improves tribological behavior. The ability to handle abrasives with these composites is not as good as that of pure silicon carbide but is significantly better than carbon-graphite. Users should review experience with this material for the specific service prior to selecting it for use.

B.2.4 Seal Ring and Mating Ring Combinations

B.2.4.1 General

Most materials exhibit poor wear behavior when in sliding contact with a surface fabricated from the same material. This is why two dissimilar materials, carbon-graphite versus silicon carbide is the standard selection in this standard. This is illustrated in Figure B.1, which compares the PV (pressure × velocity) relationship of different material combinations.

However, in some services it is usually preferable to utilize two hard faces because a soft face material wear rate might be high. Typical hard face materials are sintered silicon carbide, reaction bonded silicon carbide, and tungsten carbide. Factors that may justify the use of two hard faces include:

- a) the presence of abrasive particles in the sealed fluid;
- b) the viscosity of the fluid;
- c) crystallization of the fluid;
- d) products that polymerize;
- e) presence of high vibration and shock;
- f) high internal (ID) pressured seal faces requiring a higher face tensile strength.

B.2.4.2 Hard Face Combinations

As a general rule, two hard faces will work satisfactorily if there is sufficient liquid lubrication. However, hard face combinations will experience irreversible damage if run under dry conditions so two hard faces are not recommended for services where there will be marginal lubricating conditions. Face material development and industry experience has shown a trend toward the use of silicon carbide hard face combinations because of its greater versatility with respect to corrosion, abrasion/erosion resistance, and a lower sensitivity to face damage. There are some general rules to consider, as follows.

- a) Sintered silicon carbide vs itself can give excellent results in corrosive service and is the preferred combination of two hard faces for many chemical uses.
- b) Reaction-bonded silicon carbide vs itself has also been used extensively in hydrocarbon processing. It provides good performance for services such as crude oil where abrasive particles are present.
- c) Tungsten carbide versus silicon carbide has shown good performance where the medium sealed is oil. Even in less viscous liquid services, such as water with abrasives, tungsten carbide vs silicon carbide is the most common selection if two hard faces are required.
- d) Tungsten carbide versus tungsten carbide has been used successfully in heavy oils, tars, and asphalts. It gives poor performance in water but can be used successfully in caustic service. Special attention

should be given to the PV (pressure \times velocity) conditions, as the limits for this materials combination are lower than other hard face combinations.

- e) As a general rule, the science of tribology frowns on using two like materials in frictional contact. For this reason reaction-bonded silicon carbide, narrow face, has been used against a sintered silicon carbide, wide face. Practical concerns, such as corrosion resistance and increased inventory costs, make this a less popular combination.

Promising new materials are being developed for seal faces where hard-face combinations are required. An example is reaction bonded or sintered silicon carbide graphite loaded. RBSiCG or SSiCG versus SiC have been used successfully in some pipeline services where a variety of fluids are pumped, but detailed application guidelines are currently beyond the scope of this standard. Figure B.1 shows PV comparisons for typical face material combinations.

Crystalline diamond coated seal faces show promise in abrasive applications with marginal lubrication because of its lower coefficient of friction and improved surface hardness.

B.3 Secondary Seals

B.3.1 General

Secondary seals can be subdivided into three main groups: elastomers, energized seals, flexible graphite rings and flexible graphite filled spiral wound gaskets. The selection of these seals is important to the function and life of the mechanical seal.

B.3.2 Typical Temperature Limits for Secondary Seals

General temperature limitations can vary depending on polymeric family and composition of the elastomer, but typical values are given in Table B.4.

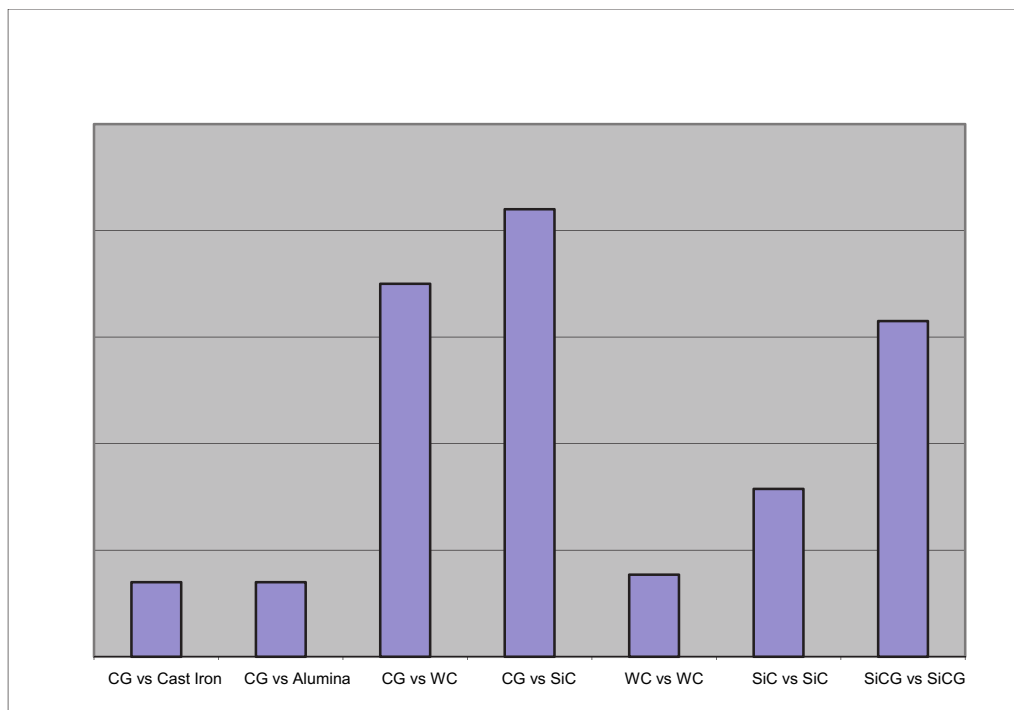

Figure B.1—Relative PV Comparisons for Seal Face Combinations

Table B.4—Typical Temperature Limits for Secondary Seals

Material	ISO/DIN 1629	ASTM D1418	Minimum Temperature °C (°F) ^a	Maximum Temperature °C (°F) ^a
Fluoroelastomer	FKM	FKM		
Hydrocarbon service			−7 (20)	176 (350)
Water-based service			−7 (20)	121 (250)
Perfluoroelastomer (high temperature)	FFKM	FFKM	0 (32)	290 (554)
Perfluoroelastomer (chemically resistant)	FFKM	FFKM	−7 (20) ^b	260 (500)
Nitrile	NBR	NBR	−40 (−40)	121 (250)
Ethylene propylene diene	EPDM	EPDM	−50 (−58)	150 (302)
Tetrafluoroethylene propylene	FEPM/ TFE	FEPM/TFE	−7 (20)	210 (410)
Polytetrafluoroethylene	PTFE	PTFE	−270 (−454)	315 (599)
Flexible graphite	—	—	−240 (−400)	480 (896)
^a The temperature ranges listed can be affected by the fluid environment.				
^b Some FFKM grades are not suitable below 20 °C (68 °F).				
NOTE Refer to Annex A, which recommends an engineered seal (ES) above and below application temperature limits of this standard that are −40 °C to 400 °C (−40 °F to 750 °F) with a 176 °C (350 °F) limit for elastomers. PTFE is not recommended secondary seal material, refer to Annex A.				

B.3.3 Elastomers

B.3.3.1 General

Elastomers are a complex integration of polymer architecture, fillers, cure chemistries and design considerations. While O-rings are not the sole elastomer configuration, they are the standard selection for secondary seals in this standard. The general characteristics discussed in this tutorial apply to all elastomer designs.

Properly selected, compounded, cured and designed elastomeric seals perform predictably in a defined service (i.e. medium, time, temperature, pressure, and static/dynamic duty). However, if compromises are made, the elastomeric seal may perform inconsistently with shortened service life.

Writing and/or applying a specification for elastomers is difficult because of the proprietary nature of elastomers, the variety of polymer architectures available and differing compound ingredients used. This standard provides only limited, general guidance for selection of elastomers and provides no specifics for selection of a particular compound, cure, and filler. It should be noted that new compounds are continuously formulated that change the possible working parameters of elastomer types and prescribing one solution for general applications/medias could exclude viable options.

B.3.3.2 Elastomer Characteristics

B.3.3.2.1 General

Elastomers are grouped into families by virtue of their base polymer. It is the base polymer that dictates the majority of the elastomer properties. Different mixtures of copolymers, fillers, compounds, and curing cycles affect the physical and chemical properties of the elastomers, which in turn effect how well the elastomer seals the media. Examples of how these mixtures affect the elastomer properties are given in B.3.3.2.2 through B.3.3.2.5.

B.3.3.2.2 FKM (Fluoroelastomer)

FKM has a vinylidene fluoride polymer base. This makes the elastomer suitable for use with hydrocarbons, silicone fluids, and water and the temperature range matches the temperature envelope of this standard for Type A and Type B seals. FKM is subdivided into three main types depending on the monomer(s) included with the base polymer in accordance with ASTM D1418. Each FKM type has different physical and chemical properties.

- *Type I*—The addition of hexafluoropropylene (HFP) increases chemical resistance.
- *Type II*—The combination of HFP and tetrafluoroethylene (TFE) increases the chemical resistance but reduces its compression set resistance and low temperature capability.
- *Type III*—The combination of HFP, TFE plus the addition of perfluoromethylvinylester (PVME) increases the chemical resistance and low temperature capabilities.

B.3.3.2.3 FFKM (Perfluoroelastomer)

FFKM has a PTFE polymer base and is not typed like FKM. The chemical inertness of the full fluorinated backbone allows excellent resistance to acids and bases, oxidizers, water and hydrocarbons. Special FFKM compounds are required for amine and steam service (see Annex A) that utilize unique crosslink and/or cure systems.

While performance variances may be minor, there is a differentiation made between chemically resistant and high-temperature FFKM. High-temperature FFKM typically has very similar chemical resistance, but because of the added high temperature range the low temperature capability is reduced. The higher temperature range and increased chemical resistance is the reason FFKM is the standard O-ring selection in this standard when FKM is not suitable.

B.3.3.2.4 NBR (Nitrile)

NBR has a base polymer of butadiene. This offers resistance to hydrocarbon applications, silicone greases, and water, but is less resistant to normal atmospheric exposure (i.e. sunlight, oxygen). The amount of the copolymer acrylonitrile within the base resin permits use in low-temperature applications, but increases susceptibility to swell in oil. NBR application temperature limit [120 °C (248 °F)] and sensitivity to some common hydrocarbon fluids (gasoline, naphtha, etc.), limit its application in some refining and chemical services. Therefore, FKM (not NBR) is the standard O-ring selection in this standard.

B.3.3.2.5 EPDM (Ethylene Propylene)

EPDM has an ethylene propylene (EP) polymer base. This offers resistance to water, steam, weak acids, phosphate ester and atmospheric exposure. The addition of ethylene propylene terpolymer (EPT) increases its resistance to oxidation and radiation. Peroxide curing increases the crosslink density and compression set resistance. However, a significant limitation for this material is its incompatibility with vegetable or mineral oils, silicone, hydrocarbons, and greases. Special handling is required to avoid contact with these fluids and lubricants and is the reason this material is reluctantly used in many refining and chemical plants.

B.3.3.3 Chemical and Mechanical Compatibility

When selecting the proper elastomer, it is important to choose an elastomer that will be compatible with the sealing fluid and lubricants used with the associated equipment. It may also be prudent to consider liquids or gases that are used to purge the pump and associated piping prior to start-up or associated with maintenance activity. Understanding and communicating the service requirements with the vendor can avoid potential media incompatibility issues such as swelling, polymerization, softening, compression set. Elastomer compatibility can vary considerably with time, temperature, concentration, and mixture of different fluids.

The seal selection guide in Annex A recommends families (FKM and FFKM) based on successful user experience. Elastomer selection should not be bound to only the recommended selection if field experience with the specific seal configuration and application has been successful. Specific elastomer application guidelines outside of those covered in Annex A are available from the following sources:

- FSA *Mechanical Seal Handbook* [55];
- HI “Mechanical Seals for Pumps: Application Guidelines” [56];
- Pruitt, Kenneth M., *Chemical Resistance for Elastomers III* [61];
- mechanical seal and elastomer manufacturers.

Subsection 6.1.1.10 requires O-ring grooves to be sized to accommodate FFKM O-rings. Some FFKMs have a greater thermal expansion than most other O-ring materials, such as FKM. Installing a FFKM in a groove designed for FKM will lead to damage to the O-ring. On the other hand, FKM O-rings function properly in the larger FFKM grooves. Choosing the wider groove as a standard eliminates this potential cause of O-ring failure and reduces the number of necessary spares. Note that thermal expansion damage in FFKM O-rings is often confused with damage due to chemical-induced swelling of the O-rings and vice versa. The O-ring groove should be designed such that at ambient and operating temperatures the O-ring will seal. A standard O-ring size reference is ISO 3601-2:2008.

Physical properties of the O-rings such as thermal expansion, elongation, hardness, and modulus vary because of the elastomer composition. The composition can alter the amount of stretch, squeeze and volume fill the O-ring can achieve. Also, extreme temperatures can vary the predicted characteristics and physical properties of the elastomer. Proper O-ring groove design helps to avoid secondary sealing problems associated with these variables.

B.3.3.4 Hardness

Elastomer hardness is measured in International Rubber Hardness Degrees (IRHD) or Shore A Durometer hardness points. Standard elastomer hardness is typically specified in 5-point increments with a ± 5 point tolerance. Density of the elastomer is directly related to the hardness. To decrease the amount of media permeation a higher hardness O-ring may be selected. Typically high-hardness O-rings have more plastic properties and will be less permeable, but elastic properties may be compromised.

Attention should be given to fillers used when increasing the density to avoid material incompatibility problems. Although most elastomers use carbon black as fillers, other fillers can be used. Chemical compatibility of the base polymer and the fillers used should be confirmed.

Table B.5 shows a typical hardness range for selected elastomers. It is important to note that the hardness ranges shown can exceed a specific elastomer durometer manufacturing tolerance. Use of elastomers with hardness outside the range successfully qualification tested may impact the ability of the seal assembly to meet the performance expectations of this standard.

Table B.5—Typical Hardness Range for Selected Secondary Seals

Material	ISO/DIN 1629	ASTM D1418	Minimum Hardness Shore A ^a	Maximum Hardness Shore A ^a
Fluoroelastomer	FKM	FKM	70	90
Perfluoroelastomer	FFKM	FFKM	70	90
Nitrile	NBR	NBR	65	75
Ethylene propylene diene	EPDM	EPDM	75	80
Tetrafluoroethylene propylene	FEPM/TFE	FEPM/TFE	75	90
Polytetrafluoroethylene	PTFE	PTFE	80	95
^a Unique compound formulation leads to varying hardness ranges. Some compounds may have hardnesses outside the above ranges.				

B.3.3.5 Other Secondary Seal Considerations

Users may wish to consider alternatives in cases where the standard elastomer O-ring materials, FKM and FFKM, do not meet all performance requirements. These alternatives normally include O-ring materials other than FKM and FFKM. Flexible graphite, while not O-ring material, is a standard secondary seal and may be a reasonable alternative. Elastomer shapes other than O-rings are rarely used. The primary factor in selecting an appropriate alternative should be proven experience and lower cost.

- a) Alternative secondary seal O-ring material may include elastomers such as nitrile rubber (NBR), hydrogenated nitrile rubber (HNBR), ethylene propylene/diene (EPM/EPDM), tetrafluoroethylene/propylene (FEPM/TFE), and FFKM alternatives/substitutes. Flexible graphite is an alternative worth considering although it is not suitable for use as a dynamic secondary seal. Tetrafluoroethylene (TFE) coated elastomer O-rings provide low friction and chemical resistance at the contact surface with a self-energizing elastomeric core; however, failure of the thin coating can result in O-ring failure so they are less often used.
- b) Bellows seals provide specific advantages as secondary seals. Problems with hang-up of dynamic O-rings caused by sludge or debris can be eliminated by substitution of bellows seals, as an example.
- c) While seldom used, spring energized polymer rings are a specific type of energized secondary seals comprised of a two part assembly; a jacket and an energizer spring retained in the jacket cavity. The inner cavity can also be energized by an elastomer. The energizer provides the positive force against the jacket lips needed to seal since the polymer lacks the resilience of an elastomer. They are used in high-pressure, polymerizing and/or low-friction applications, and only in engineered seals. The jacket material is typically PTFE because of its chemical resistance and low friction. It is important that chemical and physical suitability of all the materials used in these seals be verified.
- d) Wedge, u-cup, or v-ring shaped elastomer or PTFE material also has to be energized by external means, such as a spring, but reliability concerns associated with fretting and increased friction eliminate these as suitable alternatives within this standard.

Other considerations for selection of particular elastomeric compounds include the following:

- a) critical properties (such as compression set, swell, hardness, etc.) may be more important for some mechanical seal types than for others;

- b) dynamic secondary seals can have reduced temperature ratings;
- c) the elastomer should be identified by ISO 1629 or ASTM D1418 designation, and should not use reprocessed materials.

B.3.4 Flexible Graphite Filled Spiral Wound Gaskets and Rings

Flexible graphite is a highly conformable material that is chemically inert, naturally lubricous, and has excellent thermal conductivity. It is mechanically bonded pure graphite that enables use within the entire temperature range of this standard. It is not as robust a material as an elastomer or polymer so shall be handled more carefully or mechanically reinforced. It is less resilient than an elastomer and shall be fully contained under compression when not reinforced.

Forms of the material are fabricated from sheet. The most common use of flexible graphite is as a ring shaped static secondary seal for high-temperature bellows seals and mating rings and as filler for a spiral wound gasket. It has also been used to a lesser extent in a spring energized wedge design. Use in strong oxidizing acids is the principal limitation.

B.4 Throat and Throttle Bushings

Throat and throttle bushings can be provided by the seal vendor and the material required by this standard is carbon. Other materials have been used for pump bushings include bronze and nonmetallic materials such as polyetheretherketone (PEEK), PTFE compounds, and carbon graphite compounds.

A fixed throat bushing is normally provided by the pump vendor as part of most overhung, one and two stage pumps. Pump vendor supplied bushings for pumps with three or more stages change name and function, but there is almost always a fixed pump bushing located at the bottom of the seal chamber. If specified, the seal vendor can supply an additional throat bushing of a fixed or floating design.

Throttle bushing(s) supplied by the seal vendor are always mounted in the gland plate. Like throat bushings, some multistage pump designs are provided with bushings that they call throttle bushings. Inside the pump they are usually utilized to minimize the leakage between high-pressure pump areas to lower pressure areas.

The operating diametral clearance of solid floating carbon throat or throttle bushing will be smaller than that of a fixed bushing (in accordance with 6.1.2.23 and Table 2). The operating diametral clearance of a floating segmented bushing can be smaller than that of a solid floating bushing. The inner diameter of a solid ring floating bushing shall take into account the differential thermal expansion between the rotor (shaft and sleeve) and the bushing to avoid bushing failure. If the desired clearance for the solid floating bushing cannot be achieved or maintained because of thermal related dimensional changes then use of a segmented floating bushing may be a good choice.

Carbon bushing material is suitable for chemical plant and refining services, but can be more sensitive to impact damage than other materials. PEEK material, some graphite compounds, and PTFE (and TFE composites) may be suitable for some pump bushing applications, but they may not be the best choice for throat and throttle bushing material because of thermal expansion properties and lack of memory and are not the recommended material in this standard.

Annex C
(informative)

Mechanical Seals Datasheets

MECHANICAL SEAL DATASHEET FOR CENTRIFUGAL & ROTARY PUMPS SI UNITS / PAGE 1 OF 2 (1bar=0.1MPa)		Corporate Name and Site: Job or Project Reference: Item No. / Service Name: /			
Data to be completed by: <input type="radio"/> Purchaser <input type="checkbox"/> Seal Vendor <input type="radio"/> Purchaser or Seal Vendor		Project Phase:	INQUIRY	PROPOSAL	CONTRACT
Optional Features		Identification Number:			
		Other Identification:			
		Date / Revision Number:	/	/	/
		By:			
1	SEAL SPECIFICATION	SEAL MATERIALS		FLUID DATA (Pumped Stream, Flush Fluid)	
2	Seal Code (Annex D)	Secondary Seals (6.16.5)		Pumped Stream	
3	<input type="checkbox"/> Vendor's Seal Code	<input type="checkbox"/> FKM inner / outer seal		<input type="checkbox"/> type or name & concentration (%)	
4	<input type="checkbox"/> Vendor's Seal Drawing No.	<input type="checkbox"/> spiral-wound gasket		<input type="checkbox"/> dissolved contaminant	
5	<input type="checkbox"/> Vendor	<input type="checkbox"/> FFKM		H ₂ S _____ ml/m ³	
6	<input type="checkbox"/> Category 1 (4.12)	<input type="checkbox"/> NBR		wet _____	
7	<input type="checkbox"/> Category 2	specify: _____		Cl ₂ _____ ml/m ³	
8	<input type="checkbox"/> Category 3	<input type="checkbox"/> other @ inner seal		other, specify _____ ml/m ³	
9	<input type="checkbox"/> Arrangement 1 (4.14) piping plans:	<input type="checkbox"/> other @ outer seal		<input type="checkbox"/> solid contaminant	
10	<input type="checkbox"/> 1CW-FX (Cat. 1) 01,02,03,11,13	Seal Faces (6.16.2)		<input type="checkbox"/> concentration (mass fraction)	
11	<input type="checkbox"/> 1CW-FL (Cat. 2&3) 14,21,22,23,31	<input type="checkbox"/> Carbon / SiC inner / outer seal		<input type="checkbox"/> pumping temperature	
12	<input type="checkbox"/> 1CW-FL (Cat. 1) 32,41,51,62,65A	<input type="checkbox"/> SiC / SiC		normal _____ °C	
13	<input type="checkbox"/> segm. carb. bush. (Cat. 2&3) (7.12.1) 65B,66A,66B,99	<input type="checkbox"/> SSiC		max. _____ °C	
14	<input type="checkbox"/> Arrangement 2 (4.14) piping plans:	<input type="checkbox"/> RBSiC		min. _____ °C	
15	<input type="checkbox"/> 2CW-CW (liquid) 01,02,03,11,13	specify: _____		<input type="checkbox"/> specific gravity at indicated temperature	
16	<input type="checkbox"/> 2CW-CS (gas) 14,21,22,23,31	Metal Bellows (6.16.6)		@ normal temp. _____ kg/m ³	
17	<input type="checkbox"/> 2NC-CS (gas) 32,41,52,55,61	<input type="checkbox"/> UNS N10276 (Type B) inner / outer seal		@ max. temp. _____ kg/m ³	
18	<input type="checkbox"/> fix carbon throttle bushing (7.2.2.1) 72,75,76,99	<input type="checkbox"/> UNS N07718 (Type C)		<input type="checkbox"/> absolute vapor pressure at ref. temperature	
19	<input type="checkbox"/> Arrangement 3 (4.14) piping plans:	<input type="checkbox"/> UNS N07718 (Type B)		normal temp. _____ bar	
20	<input type="checkbox"/> 3CW-FB (liquid) 01,02,03,11,13	<input type="checkbox"/> UNS N08020		max. temp. _____ bar	
21	<input type="checkbox"/> 3CW-BB (liquid) 14,21,22,23,31	specify: _____		atmosph. boiling point _____ °C	
22	<input type="checkbox"/> 3CW-FF (liquid) 32,53A,53B,53C	<input type="checkbox"/> other @ inner seal		<input type="checkbox"/> viscosity @ norm. temp. _____ Pa.s (s. line 11)	
23	<input type="checkbox"/> flush connection 54,61,62,66A,66B,74,99	<input type="checkbox"/> other @ outer seal		<input type="checkbox"/> hazardous	
24	<input type="checkbox"/> fix carbon throttle bushing (7.3.2.2 / 7.3.2.1) 66B,74,99	Springs (6.16.4)		<input type="checkbox"/> flammable	
25	<input type="checkbox"/> 3NC-BB (gas) _____	<input type="checkbox"/> UNS N10276 or N06455 (multiple springs)		<input type="checkbox"/> other, specify _____	
26	<input type="checkbox"/> 3NC-FB (gas) _____	<input type="checkbox"/> UNS S31600 or S31635 (single spring)		<input type="checkbox"/> fluid solid @ ambient _____	
27	<input type="checkbox"/> 3NC-FB (gas) _____	Metal Parts (6.16.3 & 6.16.7)		<input type="checkbox"/> solidifies @ temp. _____ °C	
28	<input type="checkbox"/> Type A (4.13) inner / outer seal	<input type="checkbox"/> UNS S31600 or S31635		<input type="checkbox"/> pour point temp. _____ °C	
29	<input type="checkbox"/> stationary spring (6.112)	<input type="checkbox"/> UNS N10276		<input type="checkbox"/> solidifies under shear _____	
30	<input type="checkbox"/> single spring (6.15.1)	<input type="checkbox"/> UNS N08020		<input type="checkbox"/> polymerizing agents	
31	<input type="checkbox"/> Type B (4.13)	<input type="checkbox"/> other, specify _____		<input type="checkbox"/> name or type _____	
32	<input type="checkbox"/> stationary bellows (6.112)	SEAL CHAMBER DATA		<input type="checkbox"/> polymerize @ temp. _____ °C	
33	<input type="checkbox"/> Type C (4.13)	<input type="checkbox"/> ASME B73.1&2 (Category 1)		<input type="checkbox"/> plates out/decomposes _____	
34	<input type="checkbox"/> rotating bellows (6.113)	<input type="checkbox"/> cylindrical _____		<input type="checkbox"/> @ conditions _____	
35	<input type="checkbox"/> Piping Plans (Annex G) prod. - between seals - atm.	<input type="checkbox"/> tapered _____		<input type="checkbox"/> regulated for fugative or other emissions _____ ml/m ³	
36	Sleeve Shaft Drive	<input type="checkbox"/> API 610 (Category 2 & 3)		<input type="checkbox"/> special pump cleaning procedures, specify _____	
37	<input type="checkbox"/> set screws _____	<input type="checkbox"/> other, specify _____		<input type="checkbox"/> alternate process fluids & concentration, spec. _____	
38	<input type="checkbox"/> approval for _____ (6.13.14)	<input type="checkbox"/> bolt on seal chamber (6.16.8)		Flush Fluid (not required if same as pumped stream)	
39	<input type="checkbox"/> other, specify _____	<input type="checkbox"/> fixed throat bush _____		<input type="checkbox"/> type or name & concentration (%)	
40	SEAL PERFORMANCE DATA	<input type="checkbox"/> floating throat bush _____		<input type="checkbox"/> seal vendor review _____	
41	Sealing Pressure Rating	<input type="checkbox"/> seal chamber vent _____		<input type="checkbox"/> fluid temperature:	
42	<input type="checkbox"/> dynamic _____ bar(ga) (3.127)	<input type="checkbox"/> heating/cooling jacket _____		normal _____ °C	
43	<input type="checkbox"/> static _____ bar(ga) (3.184)	PUMP DATA		max. _____ °C	
44	<input type="checkbox"/> Arr. 3: continuous operation @ abnormal barrier pressure conditions [7.3.12 d)] _____	<input type="checkbox"/> Manufacturer _____		min. _____ °C	
45	Temperature	<input type="checkbox"/> model _____		<input type="checkbox"/> specific gravity at indicated temperature	
46	<input type="checkbox"/> max. allowable _____ °C (3.151)	<input type="checkbox"/> frame/size _____		@ normal temp. _____ kg/m ³	
47	<input type="checkbox"/> min. metal design _____ °C (6.16.111)	<input type="checkbox"/> Case Material _____		@ max. temp. _____ kg/m ³	
48	Additional Data for Category 3	<input type="checkbox"/> Suction Press. (rated) _____ bar (ga)		<input type="checkbox"/> absolute vapor pressure at ref. temperature	
49	<input type="checkbox"/> generated heat, normal _____ kW	<input type="checkbox"/> Discharge Pressure _____ bar (ga)		normal temp. _____ bar	
50	<input type="checkbox"/> heat soak, normal _____ kW	<input type="checkbox"/> Seal Chamber Pressure		max. temp. _____ bar	
51	<input type="checkbox"/> axial thrust on shaft _____ N	normal _____ bar (ga)		atmosph. boiling point _____ °C	
52	Test of Seal by Pump Manufacturer (10.3.6)	minimum _____ bar (ga)		<input type="checkbox"/> viscosity @ norm. temp. _____ Pa.s (s. line 48)	
53	<input type="checkbox"/> modified seal faces _____ specify faces or seal on page 2 line 54, 55	maximum _____ bar (ga)		<input type="checkbox"/> flow rate req'd max. _____ l/min	
54	<input type="checkbox"/> alternative seal _____	static _____ bar (ga)		min. _____ l/min	
55		<input type="checkbox"/> Shaft Details		<input type="checkbox"/> pressure req'd max. _____ bar (ga)	
56		diameter _____ mm		min. _____ bar (ga)	
57		speed _____ r/min			
58		horizontal _____			
59		vertical _____			
60		CW rotation _____			
61		CCW rotation _____ respective to driver			
62					
63					

MECHANICAL SEAL DATASHEET		Corporate Name and Site:			
FOR CENTRIFUGAL & ROTARY PUMPS		Job or Project Reference:			
SI UNITS / PAGE 2 OF 2 (1bar=0.1MPa)		Item No. / Service Name:		/ /	
Data to be completed by:		Project Phase:		INQUIRY PROPOSAL CONTRACT	
<input type="radio"/> Purchaser		Identification Number:			
<input type="checkbox"/> Seal Vendor		Other Identification:			
<input type="radio"/> Purchaser or Seal Vendor		Date / Revision Number:		/ / / /	
Optional Features		By:			
1 FLUID DATA (Quench, Buffer, Barrier)		SEAL AUXILIARY SYSTEM (Connection Lines, Components, Instrumentation)			
2 Quench Fluid (plan 51,62)		General		Barrier & Buffer Reservoirs (plan 52, 53A)	
<input type="radio"/> type or name		<input type="radio"/> joint user/vendor layout (8.13)		<input type="radio"/> supplier/ref. code	
<input type="radio"/> supply temp. max. °C		<input type="radio"/> supplier connect. lines		<input type="radio"/> dimensions standard	
min. °C		<input type="radio"/> support/stand		<input type="radio"/> (8.3.6.2.7) alternative	
<input type="checkbox"/> flow rate req'd max. l/min		<input type="radio"/> design limits of attached pressure casing (pump)		<input type="radio"/> other	
min. l/min		MAWP bar (ga)		<input type="radio"/> capacity 12 l d(shaft) ≤ 60 mm	
8 Buffer & Barrier Fluid (liquid/gas)		max. allow. temp. °C (8.14)		<input type="radio"/> [8.3.6.2.5 a)] 20 l d(shaft) > 60 mm	
<input type="radio"/> type or name		<input type="radio"/> design limits of seal aux. system (Category 1/2/3)		<input type="radio"/> other	
<input type="radio"/> selection: purchaser		MAWP if >20/40 bar bar (ga)		<input type="radio"/> height - seal gland/NLL m (8.3.6.2.2)	
<input type="checkbox"/> seal vendor		max. allow. temp. °C		<input type="radio"/> ASME B31.3 (8.3.6.2.8)	
<input type="checkbox"/> review: purchaser		comment		<input type="radio"/> ASME code stamp	
<input type="checkbox"/> seal vendor		<input type="radio"/> optional components		Bladder Accumulator (plan 53B)	
<input type="checkbox"/> flow rate req'd max. l/min		press. relief valve MAWP pump casing >		<input type="radio"/> supplier/ref. code	
min. l/min		in suct. piping of pump MAWP aux. system (9.8.3)		<input type="radio"/> nomin. size 20 l d(shaft) ≤ 60 mm	
<input type="checkbox"/> cooling/heating (+/-) kW		therm. relief valves (8.3.7) plan 23,52,53		35 l d(shaft) > 60 mm	
<input type="radio"/> supply pressure (< seal ch. press. for plan 52,55,72)		ext. circ. pump (8.2.24)		designed l (Table 9)	
max. bar (ga)		utility manifold conn. (8.2.24)		Piston Accumulator (plan 53C)	
min. bar (ga)		restr. orifice nipple (8.3.5.4) in flush line		<input type="radio"/> supplier/ref. code	
<input type="radio"/> fluid operating normal °C (only liquid)		other, specify		<input type="radio"/> pressure ratio	
temperature max. °C		<input type="radio"/> special requirements		<input type="radio"/> barrier liquid volume (8.3.6.4.2)	
min. °C		special alloys		min/max 0.2 / 2.8 l d(shaft) ≤ 60 mm	
<input type="radio"/> specific gravity at indicated temperature		hazardous service		min/max 0.35/5.1 l d(shaft) > 60 mm	
@ normal temp. kg/m³		other, specify		External Seal Flush Systems (plan 54 and 55)	
@ max. temp. kg/m³		<input type="radio"/> system hold up period days plan 52,53		<input type="radio"/> supplier/ref. code	
<input type="radio"/> absolute vapor pressure at ref. temperature		<input type="radio"/> filling system (8.19.5)		Collect. Reservoir for liquid leakage (plan 65, 75)	
@ normal temp. bar		<input type="radio"/> hot surface: insulation		<input type="radio"/> supplier/ref. code	
@ max. temp. bar		protection		Barrier/Buffer Gas Supply System (plan 72, 74)	
<input type="radio"/> atmosph. boiling point °C		<input type="radio"/> pipe taper threads (8.2.3)		<input type="radio"/> supplier/ref. code	
<input type="radio"/> viscosity @ norm. temp. Pa.s		ASME B1.20.1		<input type="radio"/> press. control valves (9.9)	
<input type="radio"/> specific heat capacity @ constant pressure for liquid @ normal temp. J/kg.K		ISO 7		<input type="radio"/> press. amplifier (9.10)	
33 SITE & UTILITIES		Connection Lines		INSTRUMENTATION (see also Annex G)	
<input type="radio"/> control voltage V		<input type="radio"/> tubing (8.2.8, Table 6)		<input type="radio"/> design temp. > 100 °C °C (9.17)	
<input type="radio"/> frequency Hertz		<input type="radio"/> piping (8.2.9, Table 5)		<input type="radio"/> IEC 604529,dsgn. IP65 (9.12)	
<input type="radio"/> phase		<input type="radio"/> schedule		<input type="radio"/> NEMA 250,encl. Type 4	
<input type="radio"/> electrical area CL		<input type="radio"/> size 12 mm d(shaft) ≤ 60 mm		Units (press.,temp.,level,flow)	
GR		20 mm d(shaft) > 60 mm		Temp. Indicator f. p. plan	
DIV		other mm		<input type="radio"/> bi-metallic (9.2.1) option for piping plan 32, 53B, 53C	
<input type="radio"/> ambient temp. max. °C (Design)		<input type="radio"/> heat tracing (8.2.23)		<input type="radio"/> liquid filled	
min. °C		Cooler (plan 21,22, 23, 41,53B, 53C)		Pressure-Instruments	
<input type="radio"/> cooling w ater		<input type="radio"/> supplier/ref. code		<input type="radio"/> gauges for piping plan	
<input type="radio"/> other cooling liquid		<input type="radio"/> ASME B31.3 (8.3.2.12)		<input type="radio"/> oil filled gauges (9.4.3)	
<input type="radio"/> supply temperature °C		<input type="radio"/> water cooler (8.3.2.2)		<input type="radio"/> transmitter for p. plan	
<input type="radio"/> flow rate l/min		<input type="radio"/> pipe, galvanized CS (8.2.21)		<input type="radio"/> switches for p. plan	
<input type="radio"/> Cl ₂ content ml/m³		<input type="radio"/> air cooler		<input type="radio"/> set press. min. bar (ga)	
<input type="radio"/> pressure normal bar (ga)		<input type="radio"/> natural air draft (8.3.2.3.1)		max. bar (ga)	
design bar (ga)		<input type="radio"/> forced air draft (8.3.2.3.2)		Level-Instruments (plan 52, 53A, 75)	
<input type="radio"/> ATEX group		<input type="radio"/> w. high temp. alarm		<input type="radio"/> rfl. indicator w eld pad (9.6.1)	
cat. EC Directive 94/9/EC		Cyclone Separator		removable (9.6.2)	
T class		<input type="radio"/> supplier/ref. code		<input type="radio"/> transmitter hydrostatic (9.5.3)	
52 INSPECTION & TESTING		<input type="radio"/> w. high temp. alarm		capacit. (9.5.18)	
53 Test at Pump Manufacturer - Seal Specific.		Welded Designs		ultrasonic (9.5.18)	
<input type="radio"/> modified seal faces		<input type="radio"/> purchaser approval for welded connections (6.16.10.5)		<input type="radio"/> set points high	
<input type="radio"/> alternative seal		<input type="radio"/> 100% inspection of all welds, method: (6.16.10.5)		low	
56 Miscellaneous		<input type="radio"/> magnetic particle		Flow-Instruments	
<input type="radio"/> opt. seal qual. testing (10.3.2.12)		<input type="radio"/> liquid penetrant		<input type="radio"/> flow indicator f. p. plan	
<input type="radio"/> hardness test, for		<input type="radio"/> radiographic		e.g. in cooling water outlet line (8.2.22) or plan 32	
<input type="radio"/> purchaser participation		<input type="radio"/> ultrasonic		<input type="radio"/> flow meter for p. plan	
<input type="radio"/> inspector's checklist (Annex H)				<input type="radio"/> transmitter for p. plan	
62 NOTES				<input type="radio"/> switches for p. plan	
<input type="radio"/> purchaser					
<input type="checkbox"/> seal vendor					

MECHANICAL SEAL DATASHEET FOR CENTRIFUGAL & ROTARY PUMPS U.S. CUSTOMARY UNITS / PAGE 1 OF 2		Corporate Name and Site:		
Data to be completed by:		Job or Project Reference:		
<input type="radio"/> Purchaser <input type="checkbox"/> Seal Vendor <input type="radio"/> Purchaser or Seal Vendor		Item No. / Service Name: /		
<input type="checkbox"/> Optional Features		Project Phase: INQUIRY PROPOSAL CONTRACT		
<input type="checkbox"/> Purchaser <input type="checkbox"/> Seal Vendor <input type="checkbox"/> Purchaser or Seal Vendor		Identification Number:		
<input type="checkbox"/> Purchaser or Seal Vendor		Other Identification:		
<input type="checkbox"/> Optional Features		Date / Revision Number: / / /		
By:				
1 SEAL SPECIFICATION		SEAL MATERIALS		FLUID DATA (Pumped Stream, Flush Fluid)
2 Seal Code (Annex D)		3 Secondary Seals (6.16.5)		Pumped Stream <input type="radio"/> type or name & concentration (%) <input type="radio"/> dissolved contaminant H ₂ S ppm wet Cl ₂ ppm other, specify ppm <input type="radio"/> solid contaminant <input type="radio"/> concentration (mass fraction) <input type="radio"/> pumping temperature normal °F max. °F min. °F <input type="radio"/> specific gravity at indicated temperature @ normal temp. lb/ft ³ @ max. temp. lb/ft ³ <input type="radio"/> absolute vapor pressure at ref. temperature normal temp. psi max. temp. psi <input type="radio"/> atmosph. boiling point °F <input type="radio"/> viscosity @ norm. temp. cP (s. line 14) <input type="radio"/> hazardous <input type="radio"/> flammable <input type="radio"/> other, specify <input type="radio"/> fluid solid @ ambient <input type="radio"/> solidifies @ temp. °F <input type="radio"/> pour point temp. °F <input type="radio"/> solidifies under shear <input type="radio"/> polymerizing agents <input type="radio"/> name or type <input type="radio"/> polymerize @ temp. °F <input type="radio"/> plates out/decomposes <input type="radio"/> @ conditions <input type="radio"/> regulated for fugative or other emissions ppm <input type="radio"/> special pump cleaning procedures, specify <input type="radio"/> alternate process fluids & concentration, spec.
4 Vendor's Seal Code		<input type="checkbox"/> FKM inner / outer seal <input type="checkbox"/> spiral-wound gasket <input type="checkbox"/> FFKM <input type="checkbox"/> NBR specify:		
5 Vendor's Seal Drawing No.		<input type="checkbox"/> other @ inner seal <input type="checkbox"/> other @ outer seal		
6 Vendor		Seal Faces (6.16.2) <input type="checkbox"/> Carbon / SiC inner / outer seal <input type="checkbox"/> SiC / SiC <input type="checkbox"/> SSiC <input type="checkbox"/> RBSiC specify:		
7 Category 1 (4.12)		Metal Bellows (6.16.6) <input type="checkbox"/> UNS N10276 (Type B) inner / outer seal <input type="checkbox"/> UNS N07718 (Type C) <input type="checkbox"/> UNS N07718 (Type B) <input type="checkbox"/> UNS N08020 specify:		
8 Category 2		<input type="checkbox"/> other @ inner seal <input type="checkbox"/> other @ outer seal		
9 Category 3		Springs (6.16.4) <input type="checkbox"/> UNS N10276 or N06455 (multiple springs) <input type="checkbox"/> UNS S31600 or S31635 (single spring)		
10 Arrangement 1 (4.14) piping plans:		Metal Parts (6.16.3 & 6.16.7) <input type="checkbox"/> UNS S31600 or S31635 <input type="checkbox"/> UNS N10276 <input type="checkbox"/> UNS N08020 <input type="checkbox"/> other, specify:		
11 1CW-FX (Cat. 1) 01,02,03,11,13		SEAL CHAMBER DATA <input type="checkbox"/> ASME B73.1&2 (Category 1) <input type="checkbox"/> cylindrical <input type="checkbox"/> tapered <input type="checkbox"/> API 610 (Category 2 & 3) <input type="checkbox"/> other, specify <input type="radio"/> bolt on seal chamber (6.16.8) <input type="checkbox"/> fixed throat bush <input type="checkbox"/> floating throat bush <input type="checkbox"/> seal chamber vent <input type="checkbox"/> heating/cooling jacket		
12 1CW-FL (Cat. 2&3) 14,21,22,23,31		PUMP DATA <input type="radio"/> Manufacturer <input type="radio"/> model <input type="radio"/> frame/size <input type="radio"/> Case Material <input type="radio"/> Suction Press. (rated) psi (ga) <input type="radio"/> Discharge Pressure psi (ga) <input type="radio"/> Seal Chamber Pressure normal psi (ga) minimum psi (ga) maximum psi (ga) static psi (ga) <input type="radio"/> Shaft Details diameter mm speed rpm horizontal vertical CW rotation CCW rotation respective to driver		
13 1CW-FL (Cat. 1) 32,41,51,62,65A		SEAL PERFORMANCE DATA Sealing Pressure Rating <input type="checkbox"/> dynamic psi (ga) (3.127) <input type="checkbox"/> static psi (ga) (3.184) <input type="radio"/> Arr. 3: continous operation @ abnormal barrier pressure condition [7.3.12 d)] Temperature <input type="checkbox"/> max. allow able °F (3.151) <input type="radio"/> min. metal design °F (6.16.111)		
14 segm. carb. bush. (Cat. 2&3) (7.12.1) 65B,66A,66B,99		<input type="checkbox"/> Type A (4.13) inner / outer seal <input type="checkbox"/> stationary spring (6.112) <input type="checkbox"/> single spring (6.15.1) <input type="checkbox"/> Type B (4.13) <input type="checkbox"/> stationary bellows (6.112) <input type="checkbox"/> Type C (4.13) <input type="checkbox"/> rotating bellows (6.113)		
15 Arrangement 2 (4.14) piping plans:		<input type="checkbox"/> Piping Plans (Annex G) prod. - between seals - atm. <input type="checkbox"/> Sleeve Shaft Drive <input type="checkbox"/> set screws <input type="radio"/> approval for (6.13.14) <input type="checkbox"/> other, specify		
16 2CW-CW (liquid) 01,02,03,11,13		<input type="checkbox"/> 3CW-FB (liquid) 01,02,03,11,13 <input type="checkbox"/> 3CW-BB (liquid) 14,21,22,23,31 <input type="checkbox"/> 3CW-FF (liquid) 32,53A,53B,53C <input type="checkbox"/> flush connection 54,61,62,66A, <input type="checkbox"/> fix carbon throttle 66B,74,99 bushing (7.2.2.1) 72,75,76,99		
17 2CW-CS (gas) 14,21,22,23,31		<input type="checkbox"/> 3NC-BB (gas) <input type="checkbox"/> 3NC-FB (gas) <input type="checkbox"/> 3NC-FB (gas)		
18 2NC-CS (gas) 32,41,52,55,61		<input type="checkbox"/> Type A (4.13) inner / outer seal <input type="checkbox"/> stationary spring (6.112) <input type="checkbox"/> single spring (6.15.1) <input type="checkbox"/> Type B (4.13) <input type="checkbox"/> stationary bellows (6.112) <input type="checkbox"/> Type C (4.13) <input type="checkbox"/> rotating bellows (6.113)		
19 fix carbon throttle 62,66A,66B,71		<input type="checkbox"/> Piping Plans (Annex G) prod. - between seals - atm. <input type="checkbox"/> Sleeve Shaft Drive <input type="checkbox"/> set screws <input type="radio"/> approval for (6.13.14) <input type="checkbox"/> other, specify		
20 bushing (7.2.2.1) 72,75,76,99		<input type="checkbox"/> 3NC-BB (gas) <input type="checkbox"/> 3NC-FB (gas) <input type="checkbox"/> 3NC-FB (gas)		
21 Arrangement 3 (4.14) piping plans:		<input type="checkbox"/> Type A (4.13) inner / outer seal <input type="checkbox"/> stationary spring (6.112) <input type="checkbox"/> single spring (6.15.1) <input type="checkbox"/> Type B (4.13) <input type="checkbox"/> stationary bellows (6.112) <input type="checkbox"/> Type C (4.13) <input type="checkbox"/> rotating bellows (6.113)		
22 3CW-FB (liquid) 01,02,03,11,13		<input type="checkbox"/> Piping Plans (Annex G) prod. - between seals - atm. <input type="checkbox"/> Sleeve Shaft Drive <input type="checkbox"/> set screws <input type="radio"/> approval for (6.13.14) <input type="checkbox"/> other, specify		
23 3CW-BB (liquid) 14,21,22,23,31		<input type="checkbox"/> 3NC-BB (gas) <input type="checkbox"/> 3NC-FB (gas) <input type="checkbox"/> 3NC-FB (gas)		
24 3CW-FF (liquid) 32,53A,53B,53C		<input type="checkbox"/> Type A (4.13) inner / outer seal <input type="checkbox"/> stationary spring (6.112) <input type="checkbox"/> single spring (6.15.1) <input type="checkbox"/> Type B (4.13) <input type="checkbox"/> stationary bellows (6.112) <input type="checkbox"/> Type C (4.13) <input type="checkbox"/> rotating bellows (6.113)		
25 flush connection 54,61,62,66A,		<input type="checkbox"/> Piping Plans (Annex G) prod. - between seals - atm. <input type="checkbox"/> Sleeve Shaft Drive <input type="checkbox"/> set screws <input type="radio"/> approval for (6.13.14) <input type="checkbox"/> other, specify		
26 fix carbon throttle 66B,74,99		<input type="checkbox"/> 3NC-BB (gas) <input type="checkbox"/> 3NC-FB (gas) <input type="checkbox"/> 3NC-FB (gas)		
27 bushing (7.3.2.2 / 7.3.2.1)		<input type="checkbox"/> Type A (4.13) inner / outer seal <input type="checkbox"/> stationary spring (6.112) <input type="checkbox"/> single spring (6.15.1) <input type="checkbox"/> Type B (4.13) <input type="checkbox"/> stationary bellows (6.112) <input type="checkbox"/> Type C (4.13) <input type="checkbox"/> rotating bellows (6.113)		
28 3NC-BB (gas)		<input type="checkbox"/> Piping Plans (Annex G) prod. - between seals - atm. <input type="checkbox"/> Sleeve Shaft Drive <input type="checkbox"/> set screws <input type="radio"/> approval for (6.13.14) <input type="checkbox"/> other, specify		
29 3NC-FB (gas)		<input type="checkbox"/> 3NC-BB (gas) <input type="checkbox"/> 3NC-FB (gas) <input type="checkbox"/> 3NC-FB (gas)		
30 3NC-FB (gas)		<input type="checkbox"/> Type A (4.13) inner / outer seal <input type="checkbox"/> stationary spring (6.112) <input type="checkbox"/> single spring (6.15.1) <input type="checkbox"/> Type B (4.13) <input type="checkbox"/> stationary bellows (6.112) <input type="checkbox"/> Type C (4.13) <input type="checkbox"/> rotating bellows (6.113)		
31 Type A (4.13) inner / outer seal		<input type="checkbox"/> Piping Plans (Annex G) prod. - between seals - atm. <input type="checkbox"/> Sleeve Shaft Drive <input type="checkbox"/> set screws <input type="radio"/> approval for (6.13.14) <input type="checkbox"/> other, specify		
32 stationary spring (6.112)		<input type="checkbox"/> 3NC-BB (gas) <input type="checkbox"/> 3NC-FB (gas) <input type="checkbox"/> 3NC-FB (gas)		
33 single spring (6.15.1)		<input type="checkbox"/> Type A (4.13) inner / outer seal <input type="checkbox"/> stationary spring (6.112) <input type="checkbox"/> single spring (6.15.1) <input type="checkbox"/> Type B (4.13) <input type="checkbox"/> stationary bellows (6.112) <input type="checkbox"/> Type C (4.13) <input type="checkbox"/> rotating bellows (6.113)		
34 Type B (4.13)		<input type="checkbox"/> Piping Plans (Annex G) prod. - between seals - atm. <input type="checkbox"/> Sleeve Shaft Drive <input type="checkbox"/> set screws <input type="radio"/> approval for (6.13.14) <input type="checkbox"/> other, specify		
35 stationary bellows (6.112)		<input type="checkbox"/> 3NC-BB (gas) <input type="checkbox"/> 3NC-FB (gas) <input type="checkbox"/> 3NC-FB (gas)		
36 Type C (4.13)		<input type="checkbox"/> Type A (4.13) inner / outer seal <input type="checkbox"/> stationary spring (6.112) <input type="checkbox"/> single spring (6.15.1) <input type="checkbox"/> Type B (4.13) <input type="checkbox"/> stationary bellows (6.112) <input type="checkbox"/> Type C (4.13) <input type="checkbox"/> rotating bellows (6.113)		
37 rotating bellows (6.113)		<input type="checkbox"/> Piping Plans (Annex G) prod. - between seals - atm. <input type="checkbox"/> Sleeve Shaft Drive <input type="checkbox"/> set screws <input type="radio"/> approval for (6.13.14) <input type="checkbox"/> other, specify		
38 Piping Plans (Annex G) prod. - between seals - atm.		<input type="checkbox"/> 3NC-BB (gas) <input type="checkbox"/> 3NC-FB (gas) <input type="checkbox"/> 3NC-FB (gas)		
39 Sleeve Shaft Drive		<input type="checkbox"/> Type A (4.13) inner / outer seal <input type="checkbox"/> stationary spring (6.112) <input type="checkbox"/> single spring (6.15.1) <input type="checkbox"/> Type B (4.13) <input type="checkbox"/> stationary bellows (6.112) <input type="checkbox"/> Type C (4.13) <input type="checkbox"/> rotating bellows (6.113)		
40 set screws		<input type="checkbox"/> Piping Plans (Annex G) prod. - between seals - atm. <input type="checkbox"/> Sleeve Shaft Drive <input type="checkbox"/> set screws <input type="radio"/> approval for (6.13.14) <input type="checkbox"/> other, specify		
41 approval for (6.13.14)		<input type="checkbox"/> 3NC-BB (gas) <input type="checkbox"/> 3NC-FB (gas) <input type="checkbox"/> 3NC-FB (gas)		
42 other, specify		<input type="checkbox"/> Type A (4.13) inner / outer seal <input type="checkbox"/> stationary spring (6.112) <input type="checkbox"/> single spring (6.15.1) <input type="checkbox"/> Type B (4.13) <input type="checkbox"/> stationary bellows (6.112) <input type="checkbox"/> Type C (4.13) <input type="checkbox"/> rotating bellows (6.113)		
43 SEAL PERFORMANCE DATA		<input type="checkbox"/> Piping Plans (Annex G) prod. - between seals - atm. <input type="checkbox"/> Sleeve Shaft Drive <input type="checkbox"/> set screws <input type="radio"/> approval for (6.13.14) <input type="checkbox"/> other, specify		
44 Sealing Pressure Rating		<input type="checkbox"/> 3NC-BB (gas) <input type="checkbox"/> 3NC-FB (gas) <input type="checkbox"/> 3NC-FB (gas)		
45 dynamic psi (ga) (3.127)		<input type="checkbox"/> Type A (4.13) inner / outer seal <input type="checkbox"/> stationary spring (6.112) <input type="checkbox"/> single spring (6.15.1) <input type="checkbox"/> Type B (4.13) <input type="checkbox"/> stationary bellows (6.112) <input type="checkbox"/> Type C (4.13) <input type="checkbox"/> rotating bellows (6.113)		
46 static psi (ga) (3.184)		<input type="checkbox"/> Piping Plans (Annex G) prod. - between seals - atm. <input type="checkbox"/> Sleeve Shaft Drive <input type="checkbox"/> set screws <input type="radio"/> approval for (6.13.14) <input type="checkbox"/> other, specify		
47 Arr. 3: continous operation @ abnormal barrier pressure condition [7.3.12 d)]		<input type="checkbox"/> 3NC-BB (gas) <input type="checkbox"/> 3NC-FB (gas) <input type="checkbox"/> 3NC-FB (gas)		
48 Temperature		<input type="checkbox"/> Type A (4.13) inner / outer seal <input type="checkbox"/> stationary spring (6.112) <input type="checkbox"/> single spring (6.15.1) <input type="checkbox"/> Type B (4.13) <input type="checkbox"/> stationary bellows (6.112) <input type="checkbox"/> Type C (4.13) <input type="checkbox"/> rotating bellows (6.113)		
49 max. allow able °F (3.151)		<input type="checkbox"/> Piping Plans (Annex G) prod. - between seals - atm. <input type="checkbox"/> Sleeve Shaft Drive <input type="checkbox"/> set screws <input type="radio"/> approval for (6.13.14) <input type="checkbox"/> other, specify		
50 min. metal design °F (6.16.111)		<input type="checkbox"/> 3NC-BB (gas) <input type="checkbox"/> 3NC-FB (gas) <input type="checkbox"/> 3NC-FB (gas)		
51 Additional Data for Category 3		<input type="checkbox"/> Type A (4.13) inner / outer seal <input type="checkbox"/> stationary spring (6.112) <input type="checkbox"/> single spring (6.15.1) <input type="checkbox"/> Type B (4.13) <input type="checkbox"/> stationary bellows (6.112) <input type="checkbox"/> Type C (4.13) <input type="checkbox"/> rotating bellows (6.113)		
52 generated heat, normal btu/hr		<input type="checkbox"/> Piping Plans (Annex G) prod. - between seals - atm. <input type="checkbox"/> Sleeve Shaft Drive <input type="checkbox"/> set screws <input type="radio"/> approval for (6.13.14) <input type="checkbox"/> other, specify		
53 heat soak, normal btu/hr		<input type="checkbox"/> 3NC-BB (gas) <input type="checkbox"/> 3NC-FB (gas) <input type="checkbox"/> 3NC-FB (gas)		
54 axial thrust on shaft lbf		<input type="checkbox"/> Type A (4.13) inner / outer seal <input type="checkbox"/> stationary spring (6.112) <input type="checkbox"/> single spring (6.15.1) <input type="checkbox"/> Type B (4.13) <input type="checkbox"/> stationary bellows (6.112) <input type="checkbox"/> Type C (4.13) <input type="checkbox"/> rotating bellows (6.113)		
55 Test of Seal by Pump Manufacturer (10.3.6)		<input type="checkbox"/> Piping Plans (Annex G) prod. - between seals - atm. <input type="checkbox"/> Sleeve Shaft Drive <input type="checkbox"/> set screws <input type="radio"/> approval for (6.13.14) <input type="checkbox"/> other, specify		
56 modified seal faces specify faces or seal on page 2 line 54,55		<input type="checkbox"/> 3NC-BB (gas) <input type="checkbox"/> 3NC-FB (gas) <input type="checkbox"/> 3NC-FB (gas)		
57 alternative seal		<input type="checkbox"/> Type A (4.13) inner / outer seal <input type="checkbox"/> stationary spring (6.112) <input type="checkbox"/> single spring (6.15.1) <input type="checkbox"/> Type B (4.13) <input type="checkbox"/> stationary bellows (6.112) <input type="checkbox"/> Type C (4.13) <input type="checkbox"/> rotating bellows (6.113)		
		<input type="checkbox"/> Piping Plans (Annex G) prod. - between seals - atm. <input type="checkbox"/> Sleeve Shaft Drive <input type="checkbox"/> set screws <input type="radio"/> approval for (6.13.14) <input type="checkbox"/> other, specify		
		<input type="checkbox"/> 3NC-BB (gas) <input type="checkbox"/> 3NC-FB (gas) <input type="checkbox"/> 3NC-FB (gas)		
		<input type="checkbox"/> Type A (4.13) inner / outer seal <input type="checkbox"/> stationary spring (6.112) <input type="checkbox"/> single spring (6.15.1) <input type="checkbox"/> Type B (4.13) <input type="checkbox"/> stationary bellows (6.112) <input type="checkbox"/> Type C (4.13) <input type="checkbox"/> rotating bellows (6.113)		
		<input type="checkbox"/> Piping Plans (Annex G) prod. - between seals - atm. <input type="checkbox"/> Sleeve Shaft Drive <input type="checkbox"/> set screws <input type="radio"/> approval for (6.13.14) <input type="checkbox"/> other, specify		
		<input type="checkbox"/> 3NC-BB (gas) <input type="checkbox"/> 3NC-FB (gas) <input type="checkbox"/> 3NC-FB (gas)		
		<input type="checkbox"/> Type A (4.13) inner / outer seal <input type="checkbox"/> stationary spring (6.112) <input type="checkbox"/> single spring (6.15.1) <input type="checkbox"/> Type B (4.13) <input type="checkbox"/> stationary bellows (6.112) <input type="checkbox"/> Type C (4.13) <input type="checkbox"/> rotating bellows (6.113)		
		<input type="checkbox"/> Piping Plans (Annex G) prod. - between seals - atm. <input type="checkbox"/> Sleeve Shaft Drive <input type="checkbox"/> set screws <input type="radio"/> approval for (6.13.14) <input type="checkbox"/> other, specify		
		<input type="checkbox"/> 3NC-BB (gas) <input type="checkbox"/> 3NC-FB (gas) <input type="checkbox"/> 3NC-FB (gas)		
		<input type="checkbox"/> Type A (4.13) inner / outer seal <input type="checkbox"/> stationary spring (6.112) <input type="checkbox"/> single spring (6.15.1) <input type="checkbox"/> Type B (4.13) <input type="checkbox"/> stationary bellows (6.112) <input type="checkbox"/> Type C (4.13) <input type="checkbox"/> rotating bellows (6.113)		
		<input type="checkbox"/> Piping Plans (Annex G) prod. - between seals - atm. <input type="checkbox"/> Sleeve Shaft Drive <input type="checkbox"/> set screws <input type="radio"/> approval for (6.13.14) <input type="checkbox"/> other, specify		
		<input type="checkbox"/> 3NC-BB (gas) <input type="checkbox"/> 3NC-FB (gas) <input type="checkbox"/> 3NC-FB (gas)		
		<input type="checkbox"/> Type A (4.13) inner / outer seal <input type="checkbox"/> stationary spring (6.112) <input type="checkbox"/> single spring (6.15.1) <input type="checkbox"/> Type B (4.13) <input type="checkbox"/> stationary bellows (6.112) <input type="checkbox"/> Type C (4.13) <input type="checkbox"/> rotating bellows (6.113)		
		<input type="checkbox"/> Piping Plans (Annex G) prod. - between seals - atm. <input type="checkbox"/> Sleeve Shaft Drive <input type="checkbox"/> set screws <input type="radio"/> approval for (6.13.14) <input type="checkbox"/> other, specify		
		<input type="checkbox"/> 3NC-BB (gas) <input type="checkbox"/> 3NC-FB (gas) <input type="checkbox"/> 3NC-FB (gas)		
		<input type="checkbox"/> Type A (4.13) inner / outer seal <input type="checkbox"/> stationary spring (6.112) <input type="checkbox"/> single spring (6.15.1) <input type="checkbox"/> Type B (4.13) <input type="checkbox"/> stationary bellows (6.112) <input type="checkbox"/> Type C (4.13) <input type="checkbox"/> rotating bellows (6.113)		
		<input type="checkbox"/> Piping Plans (Annex G) prod. - between seals - atm. <input type="checkbox"/> Sleeve Shaft Drive <input type="checkbox"/> set screws <input type="radio"/> approval for (6.13.14) <input type="checkbox"/> other, specify		
		<input type="checkbox"/> 3NC-BB (gas) <input type="checkbox"/> 3NC-FB (gas) <input type="checkbox"/> 3NC-FB (gas)		
		<input type="checkbox"/> Type A (4.13) inner / outer seal <input type="checkbox"/> stationary spring (6.112) <input type="checkbox"/> single spring (6.15.1) <input type="checkbox"/> Type B (4.13) <input type="checkbox"/> stationary bellows (6.112) <input type="checkbox"/> Type C (4.13) <input type="checkbox"/> rotating bellows (6.113)		
		<input type="checkbox"/> Piping Plans (Annex G) prod. - between seals - atm. <input type="checkbox"/> Sleeve Shaft Drive <input type="checkbox"/> set screws <input type="radio"/> approval for (6.13.14) <input type="checkbox"/> other, specify		
		<input type="checkbox"/> 3NC-BB (gas) <input type="checkbox"/> 3NC-FB (gas) <input type="checkbox"/> 3NC-FB (gas)		
		<input type="checkbox"/> Type A (4.13) inner / outer seal <input type="checkbox"/> stationary spring (6.112) <input type="checkbox"/> single spring (6.15.1) <input type="checkbox"/> Type B (4.13) <input type="checkbox"/> stationary bellows (6.112) <input type="checkbox"/> Type C (4.13) <input type="checkbox"/> rotating bellows (6.113)		
		<input type="checkbox"/> Piping Plans (Annex G) prod. - between seals - atm. <input type="checkbox"/> Sleeve Shaft Drive <input type="checkbox"/> set screws <input type="radio"/> approval for (6.13.14) <input type="checkbox"/> other, specify		
		<input type="checkbox"/> 3NC-BB (gas) <input type="checkbox"/> 3NC-FB (gas) <input type="checkbox"/> 3NC-FB (gas)		
		<input type="checkbox"/> Type A (4.13) inner / outer seal <input type="checkbox"/> stationary spring (6.112) <input type="checkbox"/> single spring (6.15.1) <input type="checkbox"/> Type B (4.13) <input type="checkbox"/> stationary bellows (6.112) <input type="checkbox"/> Type C (4.13) <input type="checkbox"/> rotating bellows (6.113)		
		<input type="checkbox"/> Piping Plans (Annex G) prod. - between seals - atm. <input type="checkbox"/> Sleeve Shaft Drive <input type="checkbox"/> set screws <input type="radio"/> approval for (6.13.14) <input type="checkbox"/> other, specify		
		<input type="checkbox"/> 3NC-BB (gas) <input type="checkbox"/> 3NC-FB (gas) <input type="checkbox"/> 3NC-FB (gas)		
		<input type="checkbox"/> Type A (4.13) inner / outer seal <input type="checkbox"/> stationary spring (6.112) <input type="checkbox"/> single spring (6.15.1) <input type="checkbox"/> Type B (4.13) <input type="checkbox"/> stationary bellows (6.112) <input type="checkbox"/> Type C (4.13) <input type="checkbox"/> rotating bellows (6.113)		
		<input type="checkbox"/> Piping Plans (Annex G) prod. - between seals - atm. <input type="checkbox"/> Sleeve Shaft Drive <input type="checkbox"/> set screws <input type="radio"/> approval for (6.13.14) <input type="checkbox"/> other, specify		
		<input type="checkbox"/> 3NC-BB (gas) <input type="checkbox"/> 3NC-FB (gas) <input type="checkbox"/> 3NC-FB (gas)		
		<input type="checkbox"/> Type A (4.13) inner / outer seal <input type="checkbox"/> stationary spring (6.112) <input type="checkbox"/> single spring (6.15.1) <input type="checkbox"/> Type B (4.13) <input type="checkbox"/> stationary bellows (6.112) <input type="checkbox"/> Type C (4.13) <input type="checkbox"/> rotating bellows (6.113)		
		<input type="checkbox"/> Piping Plans (Annex G) prod. - between seals - atm. <input type="checkbox"/> Sleeve Shaft Drive <input type="checkbox"/> set screws <input type="radio"/> approval for (6.13.14) <input type="checkbox"/> other, specify		
		<input type="checkbox"/> 3NC-BB (gas) <input type="checkbox"/> 3NC-FB (gas) <input type="checkbox"/> 3NC-FB (gas)		
		<input type="checkbox"/> Type A (4.13) inner / outer seal <input type="checkbox"/> stationary spring (6.112) <input type="checkbox"/> single spring (6.15.1) <input type="checkbox"/> Type B (4.13) <input type="checkbox"/> stationary bellows (6.112) <input type="checkbox"/> Type C (4.13) <input type="checkbox"/> rotating bellows (6.113)		
		<input type="checkbox"/> Piping Plans (Annex G) prod. - between seals - atm. <input type="checkbox"/> Sleeve Shaft Drive <input type="checkbox"/> set screws <input type="radio"/> approval for (6.13.14) <input type="checkbox"/> other, specify		
		<input type="checkbox"/> 3NC-BB (gas) <input type="checkbox"/> 3NC-FB (gas) <input type="checkbox"/> 3NC-FB (gas)		
		<input type="checkbox"/> Type A (4.13) inner / outer seal <input type="checkbox"/> stationary spring (6.112) <input type="checkbox"/> single spring (6.15.1) <input type="checkbox"/> Type B (4.13) <input type="checkbox"/> stationary bellows (6.112) <input type="checkbox"/> Type C (4.13) <input type="checkbox"/> rotating bellows (6.113)		
		<input type="checkbox"/> Piping Plans (Annex G) prod. - between seals - atm. <input type="checkbox"/> Sleeve Shaft Drive <input type="checkbox"/> set screws <input type="radio"/> approval for (6.13.14) <input type="checkbox"/> other, specify		
		<input type="checkbox"/> 3NC-BB (gas) <input type="checkbox"/> 3NC-FB (gas) <input type="checkbox"/> 3NC-FB (gas)		
		<input type="checkbox"/> Type A (4.13) inner / outer seal <input type="checkbox"/> stationary spring (6.112) <input type="checkbox"/> single spring (6.15.1) <input type="checkbox"/> Type B (4.13) <input type="checkbox"/> stationary bellows (6.112) <input type="checkbox"/> Type C (4.13) <input type="checkbox"/> rotating bellows (6.113)		
		<input type="checkbox"/> Piping Plans (Annex G) prod. - between seals - atm. <input type="checkbox"/> Sleeve Shaft Drive <input type="checkbox"/> set screws <input type="radio"/> approval for (6.13.14) <input type="checkbox"/> other, specify		
		<input type="checkbox"/> 3NC-BB (gas) <input type="checkbox"/> 3NC-FB (gas) <input type="checkbox"/> 3NC-FB (gas)		
		<input type="checkbox"/> Type A (4.13) inner / outer seal <input type="checkbox"/> stationary spring (6.112) <input type="checkbox"/> single spring (6.15.1) <input type="checkbox"/> Type B (4.13) <input type="checkbox"/> stationary bellows (6.112) <input type="checkbox"/> Type C (4.13) <input type="checkbox"/> rotating bellows (6.113)		
		<input type="checkbox"/> Piping Plans (Annex G) prod. - between seals - atm. <input type="checkbox"/> Sleeve Shaft Drive <input type="checkbox"/> set screws <input type="radio"/> approval for (6.13.14) <input type="checkbox"/> other, specify		

MECHANICAL SEAL DATASHEET		Corporate Name and Site:	
FOR CENTRIFUGAL & ROTARY PUMPS		Job or Project Reference:	
U.S. CUSTOMARY UNITS / PAGE 2 OF 2		Item No. / Service Name:	
Data to be completed by:		Project Phase:	
<input type="radio"/> Purchaser		INQUIRY	
<input checked="" type="radio"/> Seal Vendor		PROPOSAL	
<input type="radio"/> Purchaser or Seal Vendor		CONTRACT	
Optional Features		Identification Number:	
		Other Identification:	
		Date / Revision Number:	
		By:	
FLUID DATA (Quench, Buffer, Barrier)		SEAL AUXILIARY SYSTEM (Connection Lines, Components, Instrumentation)	
Quench Fluid (plan 51, 62) <input type="checkbox"/> type or name _____ <input type="checkbox"/> supply temp. max. _____ °F min. _____ °F <input type="checkbox"/> flow rate req'd max. _____ gpm min. _____ gpm Buffer & Barrier Fluid (liquid/gas) <input type="checkbox"/> type or name _____ <input type="checkbox"/> selection: purchaser _____ seal vendor _____ <input type="checkbox"/> review: purchaser _____ <input type="checkbox"/> seal vendor _____ <input type="checkbox"/> flow rate req'd max. _____ gpm min. _____ gpm <input type="checkbox"/> cooling/heating (+/-) _____ kW <input checked="" type="checkbox"/> supply pressure (< seal ch. press. for plan 52,55,72) max. _____ psi (ga) min. _____ psi (ga) <input type="checkbox"/> fluid operating normal _____ °F (only liquid) temperature max. _____ °F min. _____ °F <input type="checkbox"/> specific gravity at indicated temperature @ normal temp. _____ lb/ft ³ @ max. temp. _____ lb/ft ³ <input type="checkbox"/> absolute vapor pressure at ref. temperature @ normal temp. _____ psi @ max. temp. _____ psi <input type="checkbox"/> atmosph. boiling point _____ °F <input type="checkbox"/> viscosity @ norm. temp. _____ cP <input type="checkbox"/> specific heat capacity @ constant pressure for liquid @ normal temp. _____ btu/h.ft.°F		General <input type="checkbox"/> joint user/vendor layout _____ (8.13) <input type="checkbox"/> supplier connect. lines _____ <input type="checkbox"/> support/stand _____ <input type="checkbox"/> design limits of attached pressure casing (pump) MAWP _____ psi (ga) max. allow. temp. _____ °F (8.14) <input type="checkbox"/> design limits of seal aux. system (Category 1/2/3) MAWP if >20/40 bar _____ psi (ga) max. allow. temp. _____ °F comment _____ <input type="checkbox"/> optional components press. relief valve _____ MAWP pump casing > in suct. piping of pump _____ MAWP aux. system therm. relief valves _____ (9.8.3) ext. circul. pump _____ (8.3.7) plan 23,52,53 utility manifold conn. _____ (8.2.24) restr. orifice nipple _____ (8.3.5.4) in flush line other, specify _____ <input type="checkbox"/> special requirements special alloys _____ hazardous service _____ other, specify _____ <input type="checkbox"/> system hold up period _____ days plan 52,53 <input type="checkbox"/> filling system (8.19.5) <input type="checkbox"/> hot surface: insulation _____ protection _____ <input type="checkbox"/> pipe taper threads _____ (8.2.13) ASME B1.20.1 _____ ISO 7 _____	
SITE & UTILITIES <input type="checkbox"/> control voltage _____ V <input type="checkbox"/> frequency _____ Hertz <input type="checkbox"/> phase _____ <input type="checkbox"/> electrical area CL _____ GR _____ DIV _____ <input type="checkbox"/> ambient temp. max. _____ °F min. _____ °F (Design) <input type="checkbox"/> cooling water _____ <input type="checkbox"/> other cooling liquid _____ supply temperature _____ °F <input checked="" type="checkbox"/> flow rate _____ gpm <input type="checkbox"/> Cl ₂ content _____ ppm <input type="checkbox"/> pressure normal _____ psi (ga) design _____ psi (ga) <input type="checkbox"/> ATEX group _____ EC Directive cat. _____ 94/9/EC T class _____		Connection Lines <input type="checkbox"/> tubing _____ (8.2.8, Table 6) <input type="checkbox"/> piping _____ (8.2.9, Table 5) <input type="checkbox"/> schedule _____ <input type="checkbox"/> size 1/2 inch _____ d(shaft) ≤ 2.5 inch 3/4 inch _____ d(shaft) > 2.5 inch other _____ inch <input type="checkbox"/> heat tracing (8.2.23) _____ Cooler (plan 21,22,23,41,53B,53C) <input type="checkbox"/> supplier/ref. code _____ <input type="checkbox"/> ASME B31.3 _____ (8.3.2.12) <input type="checkbox"/> water cooler _____ (8.3.2.2) <input type="checkbox"/> pipe, galvanized CS _____ (8.2.21) <input type="checkbox"/> air cooler _____ <input type="checkbox"/> natural air draft _____ (8.3.2.3.1) <input type="checkbox"/> forced air draft _____ (8.3.2.3.2) <input type="checkbox"/> w. high temp. alarm _____ Cyclone Separator <input type="checkbox"/> supplier/ref. code _____	
Test at Pump Manufacturer - Seal Specific. <input checked="" type="checkbox"/> modified seal faces _____ <input checked="" type="checkbox"/> alternative seal _____ Miscellaneous <input type="checkbox"/> opt. seal qual. testing _____ (10.3.2.12) <input type="checkbox"/> hardness test, for _____ <input type="checkbox"/> purchaser participation _____ <input type="checkbox"/> inspector's checklist _____ (Annex H)		INSPECTION & TESTING Welded Designs <input type="checkbox"/> purchaser approval for welded connections _____ (6.16.10.5) <input type="checkbox"/> 100% inspection of all welds, method: magnetic particle _____ liquid penetrant _____ radiographic _____ ultrasonic _____	
NOTES <input type="radio"/> purchaser _____ <input type="radio"/> seal vendor _____		Barrier & Buffer Reservoirs (plan 52, 53A) <input type="checkbox"/> supplier/ref. code _____ <input type="checkbox"/> dimensions standard _____ <input type="checkbox"/> (8.3.6.2.7) alternative _____ <input type="checkbox"/> other _____ <input type="checkbox"/> capacity 3 U.S. gal _____ d(shaft) ≤ 2.5 inch [8.3.6.2.5 a)] 5 U.S. gal _____ d(shaft) > 2.5 inch other _____ U.S. gal _____ <input type="checkbox"/> height - seal gland/NLL _____ ft (8.3.6.2.2) <input type="checkbox"/> ASME B31.3 _____ (8.3.6.2.8) <input type="checkbox"/> ASME code stamp _____ Bladder Accumulator (plan 53B) <input type="checkbox"/> supplier/ref. code _____ <input type="checkbox"/> nomin. size 5 U.S. gal _____ d(shaft) ≤ 2.5 inch 9 U.S. gal _____ d(shaft) > 2.5 inch designed _____ U.S. gal (Table 9) Piston Accumulator (plan 53C) <input type="checkbox"/> supplier/ref. code _____ <input type="checkbox"/> pressure ratio _____ <input type="checkbox"/> barrier liquid volume (U.S. gal) _____ (8.3.6.4.2) min/max 0.05/0.7 _____ d(shaft) ≤ 2.5 inch min/max 0.09/1.28 _____ d(shaft) > 2.5 inch External Seal Flush Systems (plan 54 and 55) <input type="checkbox"/> supplier/ref. code _____ Collect. Reservoir for liquid leakage (plan 65, 75) <input type="checkbox"/> supplier/ref. code _____ Barrier/Buffer Gas Supply System (plan 72, 74) <input type="checkbox"/> supplier/ref. code _____ <input type="checkbox"/> press. control valves _____ (9.9) <input type="checkbox"/> press. amplifier _____ (9.10)	
		INSTRUMENTATION (see also Annex G) <input type="checkbox"/> design temp. > 212 °F _____ °F (9.17) <input type="checkbox"/> IEC 604529, dsgn. IP65 _____ (9.12) <input type="checkbox"/> NEMA 250, encl. Type 4 _____ Units (press., temp., level, flow) Temp.-Indicator f. p. plan _____ <input type="checkbox"/> bi-metallic _____ option for piping <input type="checkbox"/> liquid filled (9.2.1) _____ plan 32, 53B, 53C Pressure-Instruments <input type="checkbox"/> gauges for piping plan _____ <input type="checkbox"/> oil filled gauges _____ (9.4.3) <input type="checkbox"/> transmitter for p. plan _____ <input type="checkbox"/> switches for p. plan _____ <input type="checkbox"/> set press. min. _____ psi (ga) max. _____ psi (ga) Level-Instruments (plan 52, 53A, 75) <input type="checkbox"/> rfl. indicator w eld pad _____ (9.6.1) removable _____ (9.6.2) <input type="checkbox"/> transmitter hydrostatic _____ (9.5.3) capacit. _____ ultrasonic _____ <input type="checkbox"/> switches _____ (9.5.18) <input type="checkbox"/> set points high _____ low _____ Flow-Instruments <input type="checkbox"/> flow indicator f. p. plan _____ e.g. in cooling water outlet line (8.2.22) or plan 32 <input type="checkbox"/> flow meter for p. plan _____ <input type="checkbox"/> transmitter for p. plan _____ <input type="checkbox"/> switches for p. plan _____	

Annex D (informative)

Seal Codes

D.1 Introduction

The mechanical seals code provides a concise way of referring to a design and features commonly supplied with the seal.

D.2 Mechanical Seal Coding Construction

D.2.1 General

In accordance with this standard, mechanical seals can be described in a general manner by using the following simplified coding system. Table D.1 indicates the construction of a finished seal code. It is the intention of this seal code to accurately describe the seal and seal system being implemented in a given application.

Table D.1—Example of an Arrangement 1 Mechanical Seal Code

Seal			Design Options				Size	Plans		
Category	Arrangement	Type	Containment device	Gasket material	Face material	Shaft Size mm	Piping Plan			
1	1	A	-	P	F	O	-	050	-	11

D.2.2 First Position: Seal Category (1, 2, 3)

The first position designates the seal category. These categories are defined in 4.1.2.

D.2.3 Second Position: Seal Arrangement (1, 2, 3)

The seal arrangement code identifies the use of single or dual seal arrangement and also whether the dual seal arrangement is pressurized or nonpressurized. Seal arrangements are defined in 4.1.4.

D.2.4 Third Position: Seal Type (A, B, C)

This position designates the seal type (A, B, or C) as defined in 4.1.3. For dual seal assemblies with different seal types in the inner and outer position, the seal types will be designated as inner seal/outer seal (e.g. B/A).

D.2.5 Fourth Position: Containment Device (P, L, F, C, S, X)

The fourth position describes the containment device found on the atmospheric side of the mechanical seal. This device will help provide isolation of the seal from the atmosphere. The available options are shown below:

- P—plain gland with no bushing: this design can be used in Arrangement 2 or Arrangement 3 seals;

- L—floating throttle bushing: this design can be used on single Category 1, Category 2, or Category 3 seals;
- F—fixed throttle bushing: this design can be used on Category 1, Arrangement 1 seals;
- C—containment seal: a containment seal can be used in Arrangement 2 (2CW-CS or 2NC-CS) seals;
- S—floating, segmented carbon bushing: a segmented carbon bushing may be specified in Category 1, Category 2, or Category 3 seals;
- X—unspecified: the option for the containment device is unknown or not covered by the standard options. This will be specified separately.

D.2.6 Fifth Position: Secondary Sealing Element (Gasket) Material (F, G, H, I, R, X)

The fifth position describes the materials used in the secondary sealing element (gaskets) in the mechanical seal assembly. Unless otherwise specified, the material is the same for all gaskets in the assembly. For dual seal assemblies with different secondary sealing materials in the inner and outer position, the seal materials will be designated as inner seal/outer seal (e.g. G/F).

See Annex B for tutorial on secondary sealing elements. The available options are shown below:

- F—FKM gaskets;
- G—polytetrafluoroethylene (PTFE) spring energized gaskets;
- H—nitrile gaskets;
- I—FFKM gaskets;
- R—flexible graphite (with spiral wound flexible graphite gaskets for gland gasket);
- X—unspecified: the option for the secondary sealing element is unknown or not covered by the standard options. This will be specified separately.

D.2.7 Sixth Position: Seal Face Material Combination (M, N, O, P, Q, R, S, T, X)

The sixth position describes the material combination used in the seal assembly. Unless otherwise specified for dual seals, the face combination is the same for all seals in the assembly. For dual seal assemblies with different seal face materials in the inner and outer position, the seal face materials will be designated as inner seal/outer seal (e.g. P/N).

See Annex B for a tutorial on seal face materials. The available options are shown below:

- M—carbon vs nickel bound tungsten carbide;
- N—carbon vs reaction bonded silicon carbide;
- O—reaction bonded silicon carbide vs nickel bound tungsten carbide;
- P—reaction bonded silicon carbide vs reaction bonded silicon carbide;
- Q—sintered silicon carbide vs sintered silicon carbide;
- R—carbon vs sintered silicon carbide;

- S—graphite loaded, reaction bonded silicon carbide vs reaction bonded silicon carbide;
- T—graphite loaded, sintered silicon carbide vs sintered silicon carbide;
- X—unspecified: the option for the seal face material combination is unknown or not covered by the standard options. This will be specified separately.

D.2.8 Seventh Position: Shaft Size in mm

The seventh position is the shaft size onto which the seal cartridge will be installed. This size will be expressed in whole millimeters and displayed as three digits. For millimeters that are not whole or when converting inch dimensions to millimeters, the dimension should be rounded up to the next whole millimeter. This dimension is intended for seal sizing only and is not intended for detailed seal design. For an unknown or unspecified shaft size, the position will be described as XXX.

Example 1: 25 mm is described as 025.

Example 2: 37.25 mm is described as 038.

Example 3: 34.9 mm (1.375 in.) is described as 035.

Example 4: an unspecified or unknown shaft size will be described as XXX.

D.2.9 Eighth Position: Piping Plans

The eighth position defines the piping plans that will be used in the seal installation. The description of the piping plans can be found in Annex G. If more than one piping plan is used in the seal installation, the piping plans should be listed in numerical order separated by a forward slash “/”.

Example: A seal using a Plan 11 and a Plan 53A would be described as 11/53A.

D.2.10 Examples of Finished Seal Codes

Example 1: 31B-LIN-075-53A

3—Category 3

1—Arrangement 1

B—Type B seal

L—Floating bushing

I—FFKM secondary seals

N—Carbon vs reaction bonded silicon carbide

075—Installed on a 75 mm shaft

53A—Piping Plan 53A

Example 2: 12B/A-PFQ/O-050-11/52

1—Category 1

2—Arrangement 2

B/A—Type B inner seal with Type A outer seal

P—Plain gland with no bushing

F—FKM secondary seals in both inner and outer seals

Q/O—Sintered silicon carbide versus sintered silicon carbide in the inner seal with carbon vs sintered silicon carbide in the outer seal

050—Installed on a 50 mm shaft

11/52—Piping Plan 11 and Piping Plan 52

D.3 Historical Mechanical Seal Codes

For many years API 610 contained a mechanical seal coding system that was widely used in industry. This coding method provided a reference to the nomenclature and features used with mechanical seals that were current during that time period. While this coding method is obsolete and does not address the requirements of this standard, it still is still being used in some areas of industry today. It is reviewed here as a historical reference only. Table D.2 shows how the seal code was constructed.

Table D.2—API 610 Mechanical Seal Code (Obsolete)

First Digit	Second Digit	Third Digit	Fourth Digit	Fifth Digit
Design	Arrangement	Gland Plate Type	Gaskets	Seal Faces

First digit—Design

- B—balanced
- U—unbalanced

Second digit —Arrangement

- S—single
- D—double
- T—tandem

Gland plate type

- P—plain
- T—throttle bushing
- A—auxiliary sealing device

Gasket material

- E—FKM/TFE
- F—FKM
- G—TFE

- H—nitrile
- I—FFKM
- R—graphite foil
- X—as specified

Seal face materials

- J—carbon versus stellite
- K—carbon versus Ni-resist (Type 1, 2, or 3)
- L—carbon versus tungsten carbide-1 (cobalt binder)
- M—carbon versus tungsten carbide-2 (nickel binder)
- N—carbon versus silicon carbide (reaction bonded)
- O—tungsten carbide-2 (nickel binder) versus silicon carbide (reaction bonded)
- P—silicon carbide (reaction bonded) versus silicon carbide (reaction bonded)
- X—as specified

Example: BSTFN

Balanced (B) single (S) seal with a throttle bushing (T), FKM gaskets (F), and carbon versus silicon carbide faces (N).

Annex E
(normative)

Mechanical Seals Data Requirement Forms

Annex E (normative) - Data Requirements Form for Inquiries and Proposals														
Reference		Corporate Name and Site:		...										
		Job or Project Reference:		...										
Details		Item No. / Service Name:									
		Inquiry No. / By:									
		Other Identification for Inquiry		...										
		Revision No. / Date:									
DOCUMENT		DATA						user	pump vendor	seal vendor	quantity	date		
Category														
1	2	3												
Inquiry	x	x	x	Inquiry Letter <i>(with above Reference)</i>		1	define if seal chamber shall be delivered by seal or pump vendor	x	x					
				2	pump casing alloy, if better than SS 316 (corrosion, erosion)	x	x							
				3	define if ext. circulating pumps are an option (plan 23,52,53A/B/C)	x	x							
				4	special design f. continuous op. @ abnormal barrier press. condit.	x	x							
				5	design temperature of instruments > 100 °C required	x	x							
				6	additional documents (e.g. special material or test certificates)	x	x							
				7	additional job testing requirements	x	x							
				9	language(s) other than English for all or specific documents	x	x							
				9	further details / specified options	x	x							
				10	to be completed by purchaser: <input type="radio"/>	x	x							
				11	to be completed by purchaser or seal vendor: <input checked="" type="radio"/>	x	x							
Proposal	x	x	x	Proposal Letter <i>(with above Reference)</i>		12	proposed seals & auxiliary systems (type,size,material,piping plan)				x			
				13	alternatives proposed				x					
				14	deviating features & any test data of offered Engineered Seals				x					
				15	estimated seal leakage of 2NC-CS (if applicable)				x					
				16	advise if drive collar requires more than nine screws				x					
				17	specify device for seal sleeve attachment, if not set screws				x					
				18	exceptions to this standard (deviation list)				x					
				19	clarification of any design or specification differences between the test and the proposed seal				x					
				21	any conditions observed that would jeopardize the ability of the seal to meet the reliability and performance requirements				x					
				23	dynamic & static sealing pressure rating				x					
				24	max. reverse pressure (where applicable)				x					
				25	max. & min. operating temperatures				x					
				26	required connections on the pump seal chamber				x					
				27	specify if pump vendor shall provide flash tap & port connections				x					
				28	define heating or cooling requirements for pump				x					
				29	to be completed by seal vendor: <input type="checkbox"/>				x					
				30	to be completed by purchaser or seal vendor: <input checked="" type="checkbox"/>				x					
				31	modified faces for pump performance test				x					
				32	alternative seal for pump performance test				x					
				33	seal axial thrust force on shaft				x					
				34	sufficient dimensional information to check the fit of the installation in the equipment, including the seal chamber bore and depth, gland plate connections, and the distance to the nearest obstruction external to the seal chamber				x					
				35	overall seal dimensions & any relevant seal setting dimensions				x					
				36	seal axial tolerance to differential shaft/casing movement				x					
				37	key drive requirements (if applicable)				x					
				38	material specifications				x					
				39	may be on Cross-Sectional Seal Drawing				x					
				40	clarifying any pump modifications required to fit the proposed seal, showing either the seal assembly or include a cross-reference to it				x					
				41	properly conducted test & fulfilled requirements				x					
				42	test data & any other relevant information (see Annex I)				x					
				43	pipng & instrumentation diagram				x					
				44	all external utility requirements & positions				x					
				45	appropriate labelling & reference to the bill of materials				x					
				46	barrier- or buffer-fluid specification				x					
47	hydrostatic test pressure, if applicable				x									
48	maximum design pressure & temperature				x									
49	size & set pressure of relief valves				x									
50	may be on Auxiliary System Drawing				x									
51	type, quantity, size, set-pressure				x									

Annex E (normative) - Data Requirements Form for Contracts												
Reference	Corporate Name and Site:			...	DOCUMENT x: mandatory o: optional	DATA	user	pump vendor	seal vendor	quantity	date	
	Details	Job or Project Reference:										...
1		2	3	Item No. / Service Name:			...					
	Purchase Order No. / Date:			...								
Other Identification for Purchase Order			...									
Revision No. / Date:			...									
Contract	x	x	x	Purchase Order Letter	1	relevant details / specified options	x	x				
	x	x	x	Seal Chamber Drawing <i>(dimensions & locations)</i>	2	bolting, tapped connections, ports, bore, impeller end of shaft, 3 advise if register fit is outside or inside, shaft hardness	x	x				
	x	x	x	Data Sheet - acc. to Annex C <i>or alternative purchaser layout</i>	4	to be completed by purchaser: <input type="radio"/>	x	x				
					5	to be completed by purchaser or seal vendor: <input checked="" type="checkbox"/>	x	x	x			
					6	to be completed by seal vendor: <input type="checkbox"/>			x			
					7	seal axial thrust force on shaft			x			
					8	seal energy & heat-soak calculations			x			
				x	Cover Sheet	9	reference data (see above)			x		
				x	Index Sheet / Drawing List	10	list of all drawings respect. BOMs by drawing number & title			x		
		x	x		Cross-Sectional Seal Drawing to scale <i>(with above Reference)</i>	11	sufficient dimensional information to check the fit of the					
						12	overall seal dimensions & any relevant seal setting dimensions					
						13	seal axial tolerance to differential shaft/casing movement			x		
						14	material specifications					
						15	process flush rates (plan 01,11,12,13,14,21,22,23,31,32,41)					
						16	rec. fastener torques, note about gland plugs (6.1.2.18)					
						17	all seal components related to the order as well as pump					
						18	components related to the seals					
						19	dimensions to properly verify the seal setting position					
						20	pump dimensions interfacing with the seal					
						21	seal boundary dimensions, end view, port locations & symbols					
						22	seal chamber & gland plate connection dimensions					
						23	auxiliary system & utility specifications					
						24	connecting dimensions for auxiliary system & utilities			x		
						25	pump process & seal operating conditions					
						26	seal allow able axial movement from set point					
						27	seal category, type & arrangement as designated					
						28	appropriate labelling & reference to BOM,					
						29	including materials of construction and item description					
						30	process flush rates (plan 01,11,12,13,14,21,22,23,31,32,41)					
						31	rec. fastener torques, note about final gland plugs (6.1.2.18)					
	x	x	x	Detailed BOM of Seal	32	may be on drawing, recommended spare parts			x			
	x	x		Seal Instruction <i>typical</i>	33	installation (includes description of seal chamber venting),						
			x	<i>specific</i>	34	operation, maintenance			x			
			x	Circul. Device Perform. Curve	35	head versus flow based on test results			x			
					36	pipng & instrumentation diagram						
					37	all external utility requirements & positions						
					38	appropriate labelling & reference to BOM						
					39	barrier/buffer-fluid specification						
					40	hydrotest pressure (if applicable)			x			
					41	maximum design pressure & temperature						
					42	rec. fastener torques (reservoir flange, level gauge)						
					43	size & set pressure of relief valves						
					44	all mounting and overall boundary dimensions						
					45	all external utility requirements & positions						
					46	all connecting pipework locations, type and size						
					47	appropriate labelling & reference to BOM						
					48	barrier/buffer-fluid specification						
					49	equipment & alarm set points						
					50	hydrotest pressure (if applicable)						
					51	maximum design pressure & temperature						
					52	orifice sizes & rec. fastener torques (reservoir flange, level gauge)						
					53	size & set pressure of relief valves			x			
	x	x	x	Detailed BOM of Auxiliary System	54	may be on drawing, indicating recommended spare parts			x			
	x	x	x	Relief valve list	55	type, quantity, size, set-pressure			x			
	x	x		Aux. System Instruction <i>typical</i>	56	installation, operation, maintenance						
			x	<i>specific</i>	57				x			
			x	Hydro Static Test Certification	58	for pressure containing seal parts & accessories				x		
			x	Material Safety Data Sheet(s)	59	e.g. for paints, preservatives, coatings, chemicals etc.				x		
	o	o	o	Inspector Checklist (see Annex H)	60	items & dates of inspection, inspector name, status	x	x				

Annex F (informative)

Technical Tutorials and Illustrative Calculations

F.1 Seal Leakage and Leakage Management

F.1.1 Seal Leakage

There is always a mass flow rate across the face of a mechanical seal, so all seals “leak” to some extent. Some seals, particularly noncontacting seals, are designed to have a certain flow between the faces. Nevertheless, for the vast majority of pumps, there is no visible seal leakage depending on the state of the fluid being sealed. Leakage can occur regardless of seal category, type, or arrangement; however, with Arrangement 2 and Arrangement 3 dual seals, the leaked fluid may be buffer or barrier fluid instead of process fluid. Buffer and barrier fluids are often lubricating oils, which are not volatile, and wetting of the gland plate may occur leading to occasional visible droplets. However, visible leakage in the order of drops per minute is normally an indication of a seal problem. Sometimes visible leakage is apparent only over time, as the nonvolatile components of the process stream or buffer/barrier fluids accumulate.

Contacting seals may use features such as variable or low seal balance ratio or face enhancing features such as scallops, matte lapping, or preferential lapping to reduce wear and extend the design envelope; however, leakage can be slightly higher than similar seals using plain faces under less difficult conditions. Seals designed for high pressures but actually used at low pressures may have unacceptable leakage. A single contacting wet seal (1CW) sealing water at a vendor pump test ordinarily leaks a fluid that is volatile and is not visible. The aforementioned design features, necessary for specific process reliability, can in a water-sealing environment alter leakage levels such that a slight visible leakage can occur at the vendor pump test.

Factors other than design features can result in increased leakage as well; however, these may be the result of aberrant system conditions. In particular, after a contacting seal has worn in to match a certain set of operating conditions, changing those conditions can result in increased leakage until the faces have worn to match the new conditions. Such changes include fluid type, viscosity, or density in either the process or buffer/barrier fluid. Operating conditions such as temperature or pressure outside its design envelope can damage the seal and result in greater leakage rates. Other system factors that affect seal leakage rates, besides condition of the seal parts, include pump operation at off-design conditions, pipe strain, bearing problems, fitting leaks at the seal gland (often mistaken as seal leakage), impeller or sleeve gasket damage, etc.

F.1.2 Leakage Management

End face mechanical seals and devices used on the atmospheric side of these seals are a subset of the larger topic of leakage management. Depending on local laws and fluid properties different levels of leakage of the process fluid to the atmosphere or drain may be acceptable. Leakage management might include the selection of a sealless pump, or a pump with additional containment using a bushing, packing or another end face seal of either contacting or noncontacting design. Refer to Annex A for examples of end face seal selection methodology.

For example, when containment of the process fluid and zero leakage to the atmosphere is required a sealless pump or an Arrangement 3 seal may be the right choice. At the other extreme, the use of a bleed bushing in a vertical cooling water pump instead of an end face seal may be appropriate since water leaking past the bleed bushing could be directed back to the sump.

Leakage management auxiliary systems can also be attached in series with mechanical seals. With these systems, leakage can be diverted to a location determined by the plant operator. Some examples of

auxiliary systems include a separate buffer liquid lubricated outer seal and the associated support auxiliary system or a containment chamber and a sealing device for the containment chamber with its auxiliary support system. While there are many types of containment devices, three types are recommended by the standard:

- 1) simple fixed bushings;
- 2) floating bushings; and
- 3) special purpose mechanical seals that are called “containment seals.”

Selection of the appropriate containment sealing device and auxiliary system depends on the requirements for leakage control as well as expectations during normal operation and upsets.

A containment sealing device does not necessarily have the performance or rating of a mechanical seal. There are many types of containment devices, but fixed bushings have the highest release rates. Floating bushings leak significantly less than fixed bushings. Containment mechanical seals have the lowest leakage rate. Containment devices may also be used to manage quench fluids such as steam or water.

Mechanical seals used as dry running containment seals may be similar in appearance to conventional face type seals, but they include special features and materials. Although there are many variations, containment seals are designed to operate without the presence of a lubricating liquid. This ability to operate dry is possible because face material pairs have been specially developed and heat generation is very low. Containment seals may be further classified as having either contacting or noncontacting seal faces. Whereas contacting seals usually have a plain, flat face, a noncontacting seal face includes features to create aerodynamic lift that separates the faces. Noncontacting containment seals leak more than the contacting type; however, contacting containment seals have a finite wear life. Whether contacting or noncontacting, containment seals can have low leakage and long life.

Auxiliary systems used to contain process leakage from emission to the atmosphere are usually supplied with equipment that can enable the plant operator to monitor the process seal leakage rate and alarm when levels are considered excessive.

Arrangement 1 seals are usually fitted with either a fixed or floating bushing as the containment device. Optional leakage management systems for Arrangement 1 seals are Piping Plan 62 and Piping Plan 65.

Arrangement 2 seals use two mechanical seals; the outer seal can be either a conventional wet mechanical seal or a dry-running containment seal. Optional leakage management systems for Arrangement 2 are Piping Plan 52, 71, 72, 75 and 76.

F.1.3 Predicted Leakage Rates

All mechanical seals require face lubrication to achieve reliability; this results in a minimal level of leakage. On a water pump test of a contacting wet seal (1CW), the leakage typically evaporates and is not visible. Face design features, however, can increase leakage levels and visible droplets may occur (refer to A.1.3). Pressurized dual contacting wet seals (3CW), when used with a nonevaporative, lubricating oil barrier fluid, can also produce visible leakage in the form of droplets but typically at a rate less than 5.6 g/h (grams per hour) (two drops per minute).

In the choice of seal type and arrangement, the purchaser may review the appropriate service condition row in Table I.2 and consult the applicable seal vendor's qualification test results. The leakage value obtained will give a guide as to what may be expected after an adjustment is considered for differences in sealing pressure and fluid viscosity. The seal vendor should be consulted about predicted leakage rates.

Noncontacting inner seal designs utilize a lift-off face pattern, such as grooves or waves, which can provide reliable operation in liquid or gas service. Often it is difficult to provide an adequate vapor pressure margin

when sealing clean high vapor pressure or mixed vapor pressure fluids with contacting wet face designs. A noncontacting inner seal can give the option of sealing a liquid/gas mixture by allowing the product to flash into a gas across the seal faces, effectively using the noncontacting design inner seal as a gas lubricated seal. The leakage rate from a noncontacting design is normally higher than a contacting wet design.

Noncontacting containment seals utilize a face pattern (grooves, waves, etc.) to provide an aerodynamic lift of the seal faces. Contacting containment seals use the face material properties and often specific molecules in the gas such as humidity to manage the wear rate and achieve the objectives in 4.2.

Noncontacting face designs have the following benefits:

- a) lower wear rate in operation;
- b) more tolerant to higher pressures and pressure spikes created by the downstream leakage management system such as a flare or relief system;
- c) do not require maintenance check on their wear condition and function;
- d) more tolerant to a Piping Plan 72 that may utilize a low-humidity gas.

Contacting containment seals have different benefits as follows.

- The leakage rate to atmosphere, in normal and alarm conditions, is much lower. This is particularly significant when sealing a process with a high liquid content at atmospheric conditions in the inner seal leakage (see Figure F.2).
- The flat face design is more reliable when there is a significant liquid content in the inner seal leakage.

Figure F.1 shows expected relative gas leakage rates for different containment devices typically used in Arrangement 1 and Arrangement 2 configurations, assuming a differential pressure across the device of 0.07 MPa (0.7 bar) (10 psi). This pressure is a common containment seal chamber alarm pressure setting and would be a gauge pressure assuming the leakage across the device is to atmosphere.

Figure F.2 shows expected relative water leakage rates for the same devices shown in Figure F.1 but at a differential pressure of 0.275 MPa (2.75 bar) (40 psi).

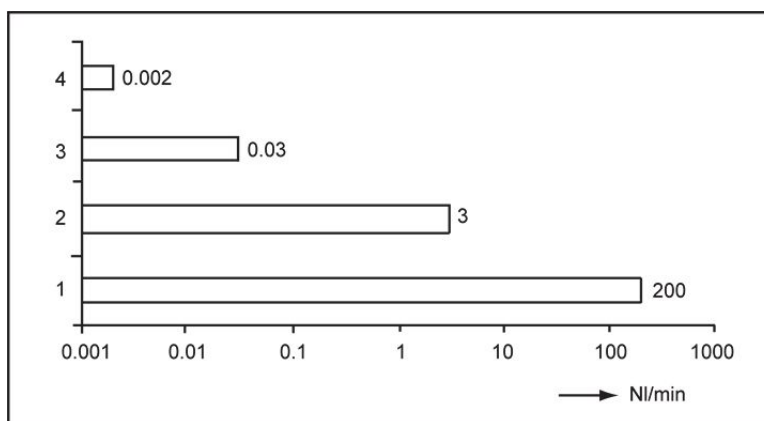

Key

- 1 solid floating bushing
- 2 segmented floating bushing
- 3 noncontact gas seal
- 4 contact gas seal

Figure F.1—Estimated Gas Leakage for 50 mm Shaft at 0.7 bar, Expressed in Normal Liters per Minute

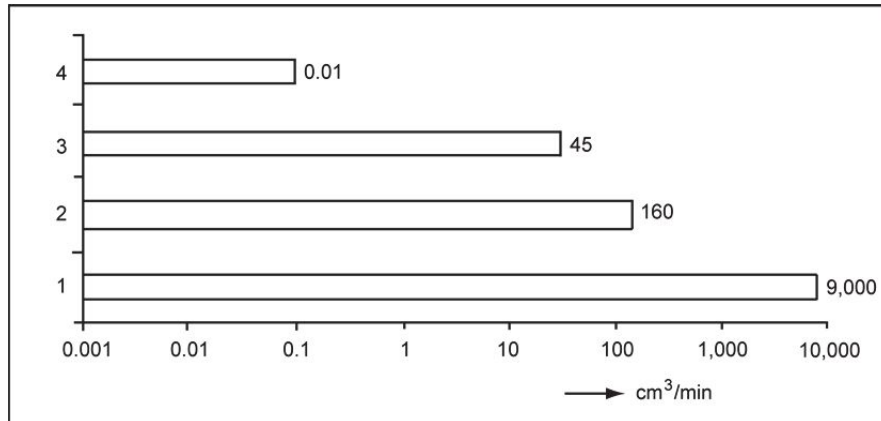
**Key**

- 1 solid floating bushing
- 2 segmented floating bushing
- 3 noncontact gas seal
- 4 contact gas seal

Figure F.2—Estimated Liquid (Water) Leakage for 50 mm Shaft at 2.75 bar, Expressed in Cubic Centimeters per Minute

F.1.4 Vapor Pressure Margin and Product Temperature Margin

F.1.4.1 Lubrication Between Seal Faces

It is assumed that reliable seal performance requires liquid between the faces for lubrication. Since most seals have no visible leakage, it is accepted that the liquid between the faces vaporizes at some point as it travels across the face to the atmospheric side of the seal. The amount of gas between the seal faces of an idealized seal depends on the fluid properties, sealing pressure, and sealing temperature. For example, high vapor pressure fluids like propane will have a large percentage of the seal face width operating with gas between the faces. The Hydrocarbon Processing Industries use this ratio of liquid/gas as the basis for criteria used to predict seal face performance. It is reinterpreted as a vapor pressure margin (see below). Most seal vendors have modeling programs to estimate the fluid state transition point. However, when dealing with fluid mixtures or pump systems designed to handle more than one fluid, optimizing seal selection and piping plans can be more involved.

F.1.4.2 Vapor Pressure Margin and Product Temperature Margin

A pressure margin between seal chamber pressure and the maximum liquid vapor pressure is included in 6.1.2.14.2 because it has proved to be easy to administer and it correlates well with other methods of evaluating seal suitability for given service conditions as measured by seal life at an acceptable seal leakage rate.

The pressure margin between seal chamber pressure and the maximum liquid vapor pressure applies to contacting wet Arrangement 1 seals and the inner seal of an Arrangement 2 configuration. This margin is considered a threshold below which seal vendors shall more closely consider the seal piping plan, seal selection, and configuration of adaptive hardware to achieve an acceptable service life.

The standard recognizes some pumps that develop low differential pressure and pumps that handle high vapor pressure fluids may not achieve the required margins. For contacting wet seal designs, maintaining an adequate vapor pressure margin helps protect the seal faces against excessive levels of localized boiling of the process fluid at the seal faces. Boiling of the process fluid at the seal faces can cause loss of seal face lubrication and subsequent seal failure. Low-density fluids that are pumped with low vapor

pressure margins are some of the most troublesome fluids to seal and account for a high percentage of seal repairs.

Methods for achieving the required pressure margin may utilize one or a combination of the following options. The selection and application of these solutions is usually the result of mutual agreement between the purchaser and the seal and pump vendors.

- a) Lowering the seal chamber fluid temperature by cooling the flush fluid.
- b) Raising the seal chamber pressure by removing the back wear ring and plugging impeller balance holes.
- c) Utilizing an external flush fluid.
- d) Raising the seal chamber pressure through the use of a close clearance (floating) throat bushing.

Lowering the flush fluid temperature (seal-chamber fluid temperature) is always preferable to pressurizing the seal chamber by using a close clearance throat bushing. Bushing wear over a period of operating time inevitably results in a decreased seal chamber pressure and margin over vapor pressure.

If the pump is vertical and a Piping Plan 13 is required to assist in vapor removal from the seal face environment, a Piping Plan 14 with a distributed flush injection is a possible solution combining both features.

Some applications may not need complicated seal flush systems or the 0.35 MPa (3.5 bar) (50 psi) margin between seal chamber pressure and vapor pressure. A generic example of this is cooling water service. Assuming the water is a 38 °C (100 °F) with an atmospheric pump suction and seal chamber pressure, the vapor pressure would be an absolute pressure of 0.0065 MPa (0.065 bar) (0.94 psia). The absolute vapor pressure at 58 °C (136 °F), a 20 °C product temperature margin (PTM), would be about 0.018 MPa (0.18 bar) (2.7 psia). Ample PTM would be present in the seal chamber to achieve the expected three-year seal life without seal flush fluid cooling or pressurizing the seal chamber to provide a 0.35 MPa (3.5 bar) (50 psi) margin over vapor pressure.

The idea of a vapor pressure margin requirement dates to the Fifth Edition (1971) of API 610 pump specification (if not earlier) requiring seal chamber pressure to be 0.172 MPa (1.72 bar) (25 psi) above suction pressure (assumed to be roughly equal to seal chamber pressure). API 610, Sixth Edition contained the same requirement. API 610, Seventh Edition called for conditions leading to a stable film at the seal faces to be jointly established by pump and seal vendors. The Eighth Edition of API 610 referred to API 682, First Edition, which required a margin of at least 0.35 MPa (3.5 bar) (50 psi) above the maximum vapor pressure.

Figure F.3 graphically represents the different methods of calculating the actual operating margins and the vapor pressure ratio for a specific process and operating point. The minimum operating margins stated above and the values discussed in the next subsection are performance recommendations for each method to achieve reliable seal face function. Figure F.4 uses the value(s) discussed in the next subsection and it illustrates how the pressure and temperature margins between process liquid vapor pressure and minimum recommended seal chamber pressure vary between the three calculating methods for a propane service.

The vapor pressure margin recommended in API standards and subsequently ISO standards is primarily aimed at hydrocarbon services where the process liquid is often pumped close to its saturated vapor pressure. Sealing of water-based liquids becomes more sensitive to vapor pressure margin and they are typically rated to operate reliably with a temperature margin below their atmospheric boiling point.

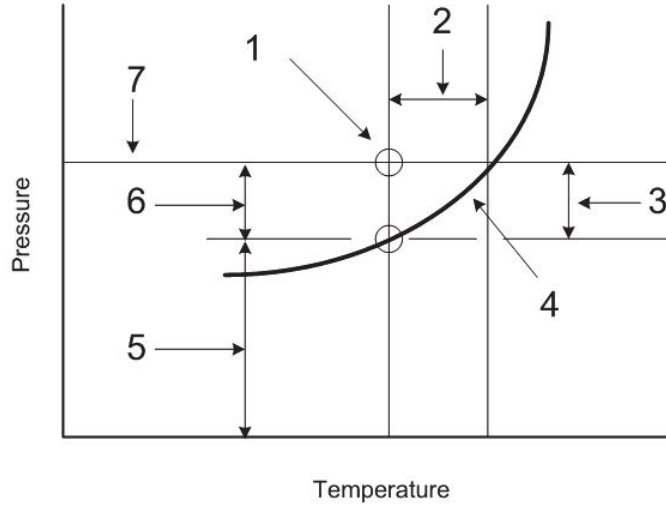

Key

- 1 operating point
- 2 product temperature margin (PTM)
- 3 vapor pressure margin
- 4 liquid vapor pressure curve
- 5 vapor pressure at process temperature (VP)
- 6 vapor pressure ratio (SP/VP)
- 7 seal chamber pressure (-SP)

Figure F.3—Illustration of Alternative Vapor Pressure Margin Calculation Options

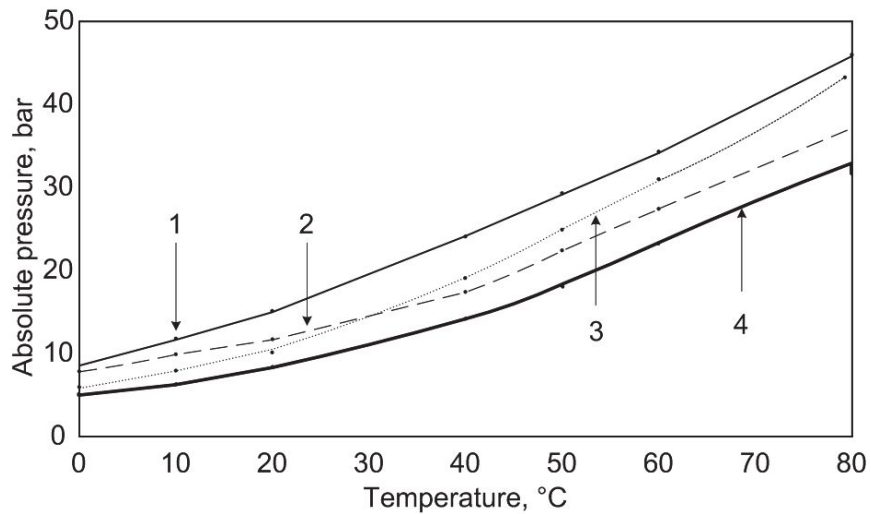

Key

- 1 20 °C (68 °F) product temperature margin
- 2 3.5 bar (50 psi) margin
- 3 1.3 ratio over vapor pressure
- 4 vapor pressure curve

Figure F.4—Illustration of Vapor Pressure Margin Calculation Methods as Applied to Propane

F.1.4.3 Fixed Ratio or Product Temperature Margin in API 682, Second and Third Editions

Although temperature and vaporization are probably better indicators of reliability, pressure has become the parameter of choice. The pressure margin in API 682 First Edition of 0.35 MPa (3.5 bar) (50 psi) can be viewed as a “pressure interpretation of a temperature requirement.” For example, the previous edition of this standard required a “product temperature margin” (PTM) of not less than 20 °C (36 °F) or a ratio of seal chamber pressure to maximum vapor pressure of 1.3 (130 %). PTM is the difference between the process temperature in the seal chamber and the saturation temperature of the process liquid at the seal chamber pressure. As an example, the API 682 qualification tests on propane are at 32 °C (90 °F) and a pressure of 1.8 MPa (18 bar) (261 psia). The saturation temperature of propane at 1.8 MPa (18 bar) (261 psia) is 52 °C (126 °F). Therefore, the API 682 tests are based on a PTM of 52 °C – 32 °C = 20 °C (126 °F – 90 °F = 36 °F). Although PTM is a single component concept, for mixtures it can be based on the bubble point, but this can be a complex calculation.

Seals with good heat transfer designs (wetted area, thermal conductivity, convection heat transfer) and reduced heat generation (low speed, low pressure, low balance ratio, hydropads, narrow faces, low spring loads, good tribological mating faces) can operate with a smaller PTM than seals without these good characteristics. The fixed minimum margins stated in API 682 are values that general field experience has proven to give reliable operation. Some seal vendors may claim success at lower margins and this is possible but shall be judged in the context of the specific fluid characteristics and pump service conditions.

A fixed ratio (at least 1.3) between the seal chamber pressure and maximum fluid vapor pressure is a criterion appropriate for hydrocarbons with a steep saturation pressure versus temperature curve and lower pressure applications, but reaches a practical limit at very high pressures. Ratios around 1.3 are usually acceptable for seals using premium materials, having good heat transfer characteristics and having good flush designs with adequate flush rates, like API 682 Type A seals.

The standard reverts back to the 0.35 MPa (3.5 bar) (50 psi) vapor pressure margin in API 682, First Edition. This simpler performance evaluation strategy is adequate for most hydrocarbon services, but may be inadequate on high vapor pressure services. The use of product temperature margin or a 30 % pressure margin between seal chamber pressure and maximum vapor pressure are reasonable alternate methods for determining that a seal will achieve three years of uninterrupted service, but specific fluid characteristics required with this method may not be readily available.

F.2 Seal Chamber Temperature Rise and Flush

F.2.1 General

The steady-state temperature of the fluid in the seal chamber is a function of a simple thermodynamic balance. The heat flow into the seal chamber fluid minus the heat flow out of the seal chamber yields a zero net heat flow. This is deceptively simple. In actual applications, the heat flows into and out of the seal chamber fluids are extremely complex.

There are several sources of heat flow into the fluid. These include heat generated because of friction and fluid shear at the seal faces, heat generated because of turbulence caused by the rotating seal components, and heat conducted from the pump through the seal chamber and shaft (or positive heat soak). There are also several sources of heat flow out of the seal chamber. These include heat conducted back into the pump through the seal chamber or shaft (or negative heat soak) and heat lost to the atmosphere through convection and radiation.

When seal face generated heat, heat soak, balance ratio, fluid properties and other factors are combined, required flush flow rates or temperature rise in the seal chamber can be calculated. While operating margin between fluid vapor pressure and flush fluid temperature can determine the correct piping plan and flow rate, a flush flow rate that results in the recommended temperature rise are generally considered adequate to meet seal life expectations. Achieving the required buffer and barrier liquid flow rates with seal

Piping Plan 52 or Piping Plan 53 A/B/C that utilize an internal circulating device requires special attention to the piping system curves for these systems (see F.3.1 and 3.2). Starting torque, seal power and seal generated heat can be significant issues for small pump drivers, seals at or above the balance diameter and pressure boundaries of this standard, and for Arrangement 3 seals. Certain seal chamber arrangements such as dead-ended and taper bore boxes have other considerations.

F.2.2 Seal Face Generated Heat

F.2.2.1 General

While the calculation of the heat generated by a mechanical seal appears to be a simple matter, several assumptions shall be made that introduce potentially large variations in the results. Two variables that are particularly influential are K , the pressure drop coefficient, and f , the effective coefficient of friction.

K is a number between 0.0 and 1.0 that represents the pressure drop as the sealed fluid migrates across the seal faces. For flat seal faces (parallel fluid film) and a nonflashing fluid, K is approximately equal to 0.5. For convex seal faces (converging fluid film) or flashing fluids, K is greater than 0.5. For concave seal faces (diverging fluid film), K is less than 0.5. Physically, K is the coefficient that is used to quantify the amount of differential pressure across the seal faces that is transmitted into the hydraulic component of the fluid film support forces, referred to as the opening forces. The opening force is expressed by the following equation:

$$F_O = A \times \Delta p \times K \quad (\text{F.1})$$

where

- F_O is the opening force, expressed in Newtons;
- A is the area of the seal face, expressed in square millimeters;
- Δp is the differential pressure, expressed in megapascals;
- K is the pressure drop coefficient, dimensionless.

For practical purposes, K varies between 0.5 and 0.8. As a standard practice for nonflashing fluids though, a value of 0.5 is selected for K . Although K is known to vary depending upon seal fluid properties (including multiphase properties) and film characteristics (including thickness and coning), this value is selected as a benchmark for consistent calculation; nevertheless, the engineer shall be made aware that this assumption has been made.

The effective coefficient of dynamic friction, f , is a number that is similar to the standard coefficient term that most engineers are familiar with. The standard coefficient of friction term is used to represent the ratio of parallel forces to normal forces. This is normally applied to the interaction between two surfaces moving relatively. These surfaces may be of the same material or different materials.

In a mechanical seal, the two relatively-moving surfaces are the seal faces. If the seal faces were operating dry, it would be a simple matter to determine the coefficient of friction. In actual operation, the seal faces operate under various lubrication regimes, and various types of friction are present.

If there is significant asperity contact, f is highly dependent on the materials and less dependent on the fluid viscosity. If there is a very thin fluid film (only a few molecules thick), friction may depend upon interaction between the fluid and the seal faces. With a full fluid film, there is no mechanical contact between the faces and f is solely a function of viscous shear in the fluid film. All of these types of friction can be present at the same time on the same seal face.

An effective coefficient of friction is used to represent the gross effects of the interaction between the two sliding faces and the fluid film. Actual testing has shown that normal seals operate with f between about 0.01 and 0.18. For normal seal applications, this standard has selected a value of 0.07 for f . This is reasonably

accurate for most water and medium hydrocarbon applications. Viscous fluids (such as oils) will have a higher value, while less viscous fluids (such as LPG or light hydrocarbons) can have a lower value.

The combination of the assumption of K and the assumption of f can lead to a significant deviation between calculated heat generation results and actual results. Therefore, the engineer shall keep in mind that these calculations are useful only as an order-of-magnitude approximation of the expected results. These results shall never be stated as a guarantee of performance.

Calculation of the effective frictional face generated heat first requires an evaluation of the normal forces on the seal face. The opening force has already been discussed but the opposing closing force (normally the higher value) is a sum of the seal spring force and a hydraulic force determined by the seal ring design (see F.2.2.2). The seal face generated heat is the normal force (difference between the closing and opening forces) multiplied by the effective coefficient of friction and translated into a heat rate by adjusting for diameter and shaft speed (see F.2.2.4.8).

F.2.2.2 Balance Ratio

F.2.2.2.1 General

Seal vendors design seal faces with a balance ratio to minimize seal face generated heat consistent with optimum seal life expectations and emission limits. The balance ratio impacts the face loading, heat generated and the pressure rating of the seal. A balanced seal design will have a balance ratio less than 1, typically in the range of 0.6 to 0.9. The balance ratio can be interpreted as the proportion of the seal chamber pressure that is helping to create the closing force on the seal face. For example, the typical range of 0.6 to 0.9 balance ratio means that there is a 10 % to 40 % reduction in the hydraulic pressure load on the faces. Type A pusher seal designs will often require a step in the shaft sleeve as shown in Figure F.5. The step in the shaft sleeve increases the area of the seal face on which seal chamber pressure is offset or balanced resulting in a reduction in face load and face generated heat.

Balance diameter varies with seal design, but for Type A seals it is normally the diameter of the sliding contact surface of the dynamic O-ring. For the inner Type A seal of a dual seal configuration the sliding surface can vary depending on whether the pressure is internal or external. For Type B and Type C seals, the balance diameter is normally the mean diameter of the bellows, but this will vary with the pressure. Contact the seal vendor for determination of the balance diameter under varying pressure conditions.

An example of the seal balance ratio measurement points shall be as shown in Figure F.5. There are other methods of achieving pressure balance under pressure reversals. Contact the seal vendor if the sliding contact surface of the dynamic O-ring is not readily apparent.

F.2.2.2.2 Calculation Inputs

D_o is the seal face outside diameter;

D_i is the seal face inside diameter;

D_b is the balance diameter of the seal.

F.2.2.2.3 Formula

For seals externally pressurized, the seal balance ratio, B , is defined by the equation:

$$B = (D_o^2 - D_b^2) / (D_o^2 - D_i^2) \quad (\text{F.2})$$

For seals internally pressurized, the seal balance ratio, B , is defined by the equation:

$$B = (D_b^2 - D_i^2) / (D_o^2 - D_i^2) \quad (\text{F.3})$$

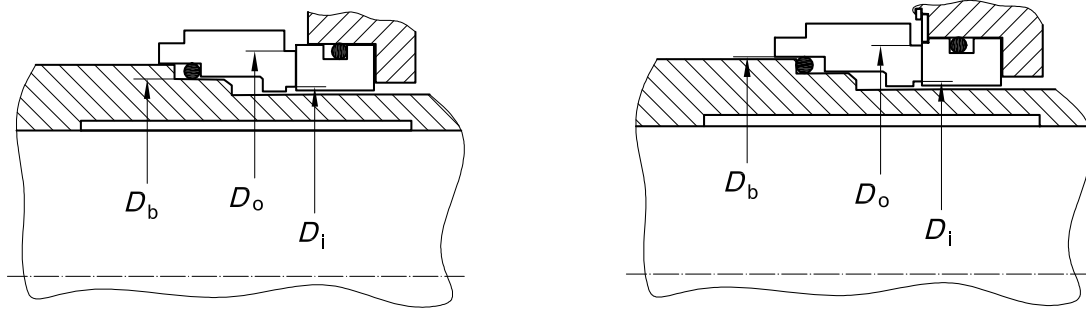

a) Seal with Higher Pressure at Outer Diameter b) Seal with Higher Pressure at Inner Diameter

Figure F.5—Illustration of Balance Ratio Measurement Points

F.2.2.3 Seal Face Generated Heat Calculation Inputs

Required inputs:

D_o is the seal face contact outer diameter, expressed in millimeters;

D_i is the seal face contact inner diameter, expressed in millimeters;

D_b is the effective seal balance diameter, expressed in millimeters;

F_{sp} is the spring force at working length, expressed in Newtons;

Δp is the pressure differential across the seal face, expressed in megapascals;

n is the face rotational speed, expressed in revolutions per minute;

f is the coefficient of friction (assume 0.07);

K is the pressure drop coefficient (assume 0.5).

F.2.2.4 Seal Face Generated Heat Calculation Formula

F.2.2.4.1 Face Area, A (mm^2)

$$A = \frac{\pi(D_o^2 - D_i^2)}{4} \quad (\text{F.4})$$

F.2.2.4.2 Seal Balance Ratio, B

$$B = \left(\frac{D_o^2 - D_b^2}{D_o^2 - D_i^2} \right) \quad (\text{F.5})$$

F.2.2.4.3 Spring Pressure, p_{sp} (MPa)

$$p_{sp} = \frac{F_{sp}}{A} \quad (\text{F.6})$$

F.2.2.4.4 Total Face Pressure, p_{tot} (MPa)

$$p_{\text{tot}} = \Delta p(B - K) + p_{\text{sp}} \quad (\text{F.7})$$

F.2.2.4.5 Mean Face Diameter, D_{m} (mm)

$$D_{\text{m}} = \frac{(D_{\text{o}} + D_{\text{i}})}{2} \quad (\text{F.8})$$

F.2.2.4.6 Running Torque, T_{r} (N m)

$$T_{\text{r}} = p_{\text{tot}} \times A \times f \left(\frac{D_{\text{m}}}{2000} \right) \quad (\text{F.9})$$

F.2.2.4.7 Starting Torque, T_{s} (N m) Estimated at 3 to 5 Times Running Torque

$$T_{\text{s}} = T_{\text{r}} \times 4 \quad (\text{F.10})$$

F.2.2.4.8 Seal Face Generated Heat Power, P (kW)

$$P = (T_{\text{r}} \times N) / (9548) \quad (\text{F.11})$$

F.2.2.5 Example Calculation

Fluid: Water

Pressure: 2 MPa (20 bar) (290 psi)

Speed: 3000 r/min

Inputs:

$$D_{\text{o}} = 61.6 \text{ mm (2.425 in.)}$$

$$D_{\text{i}} = 48.9 \text{ mm (1.925 in.)}$$

$$D_{\text{b}} = 52.4 \text{ mm (2.063 in.)}$$

$$F_{\text{sp}} = 190 \text{ N (42.71 lb force)}$$

$$\Delta p = 2 \text{ MPa (20 bar) (290 psi)}$$

$$n = 3000 \text{ r/min}$$

$$f = 0.07$$

$$K = 0.5$$

Equation (F.4) gives:

$$A = \left(\frac{\pi}{4} \right) \times (61.6^2 - 49.9^2) = 1102 \text{ mm}^2 (1.708 \text{ in.}^2)$$

Equation (F.5) gives:

$$B = \frac{(61.6^2 - 52.4^2)}{(61.6^2 - 48.9^2)} = 0.746$$

Equation (F.6) gives:

$$p_{\text{sp}} = \left(\frac{190}{1102} \right) = 0.172 \text{ N/mm}^2 (0.172 \text{ MPa}) (24.946 \text{ psi})$$

Equation (F.7) gives:

$$P_{\text{tot}} = 2 (0.746 - 0.5) + 0.172 = 0.664 \text{ N/mm}^2 (0.664 \text{ MPa}) (96.305 \text{ psi})$$

Equation (F.8) gives:

$$D_{\text{m}} = \frac{(6.16 + 48.9)}{2} = 55.25 \text{ mm} (2.175 \text{ in.})$$

Equation (F.9) gives:

$$T_{\text{r}} = 0.664 \times 1102 \times 0.07 \left(\frac{55.25}{2000} \right) = 1.42 \text{ N} \cdot \text{m} (1.047 \text{ ft} \cdot \text{lb})$$

Equation (F.10) gives:

$$T_{\text{s}} = 1.42 \times 4 = 5.68 \text{ N} \cdot \text{m} (4.189 \text{ ft} \cdot \text{lb})$$

Equation (F.11) gives:

$$P = (1.42 \times 3000)/9548 = 0.446 \text{ kW} (0.6 \text{ HP})$$

F.2.3 Heat Soak

F.2.3.1 General

Heat soak is the heat transferred from the pump and pumped fluid to fluid in the seal chamber. The pump and pumped fluid heat is transferred into and out of the seal chamber in amounts dependent of service conditions and pump design.

In some cases, assumptions can be made that simplify the model. For example, consider a single seal with Piping Plan 11, 12, 13, or 31. With these piping plans, the fluid injected into the seal chamber will be at pump temperature so heat soak and heat loss to the atmosphere can be ignored. Except in the case of large seals at high speeds, heat generation due to liquid turbulence is usually insignificant and can also be ignored.

In applications that use a Piping Plan 21, 22, 23, 32, or 41, the fluid injected into the seal chamber may be at a significantly lower temperature than the pump temperature. If this is the case, there can be a significant heat flow or heat soak into the seal chamber from the pump. The calculation of heat soak is a complex matter, requiring detailed analysis or testing and a thorough knowledge of the specific pump construction and pumped product properties. Experience has shown in the hydrocarbon processing industries that efforts to minimize heat soak with the use of cooling water in seal chamber jackets have been largely unsuccessful because of fouling and the cross sectional thickness of the pump parts.

It is necessary for the seal vendor to make an estimation of the rate of heat soak and the empirical formula below can be used to provide an estimation of the level. It is unable to consider all the differences in equipment design and hence the prediction is usually greater than may be experienced in the field.

F.2.3.2 Heat Soak Calculation Inputs

U is the material property coefficient;

A is the effective heat transfer area;

D_b is the seal balance diameter, expressed in millimeters;

ΔT is the difference between pump temperature and desired seal chamber temperature, expressed in Kelvin.

A typical value for $(U \times A)$ that can be used for estimating purposes with stainless steel sleeve and gland construction and steel pump construction is 0.00025. This value will generally provide a conservative estimate of heat soak.

F.2.3.3 Heat Soak Formula

If specific knowledge of the pump construction and pumped product properties is not available, the heat soak [Q_{hs} (kW)] can be estimated by the equation:

$$Q_{hs} = U \times A \times D_b \times \Delta T \quad (F.12)$$

F.2.3.4 Example Calculation

$$U \times A = 0.00025$$

$$D_b = 55 \text{ mm (seal balance diameter)}$$

$$\text{pump temperature} = 175 \text{ }^\circ\text{C (347 }^\circ\text{F)}$$

$$\text{desired seal chamber temperature} = (65 \text{ }^\circ\text{C) (149 }^\circ\text{F)}$$

$$\Delta T = 175 - 65 = 110 \text{ K (110 }^\circ\text{C) (198 }^\circ\text{F)}$$

$$Q_{hs} = 0.00025 \times 55 \times 110 = 1.5 \text{ kW (2.01 HP)}$$

F.2.4 Seal Flush Fluid Temperature Rise

F.2.4.1 General

Temperature rise of the flush fluid as it travels through the seal chamber is a function of a thermodynamic balance applied to a liquid flow rate. The seal face generated heat is added to the heat soak, if relevant to

the piping plan, and applying this to a known flow rate using a thermodynamic formula, a temperature rise can be predicted. The choice of whether the heat soak is included is discussed in F.2.2.

The temperature rise calculated using the following formulas results in the average temperature rise of the flush fluid in the seal chamber. However, within the seal chamber, there are areas that are hotter and cooler than the mean fluid temperature. An effective flush design and flow rate is required to ensure that the area around the seal face is effectively cooled.

F.2.4.2 Calculation Inputs

- Q is the heat generation at the seal faces, expressed in kilowatts;
- Q_{heatsoak} is the heat transferred from the pump and pumped fluid to fluid in the seal chamber, expressed in kilowatts;
- q_{inj} is the injection flow rate, expressed in liters per minute;
- d is the relative density (specific gravity) of the injected fluid at pump temperature;
- c_p is the specific heat capacity of the injected fluid at pump temperature, expressed in joules per kilogram Kelvin.

F.2.4.3 Formula—Without Heat Soak

The differential temperature, ΔT (in Kelvin), can be calculated by the following equation:

$$\Delta T = \frac{(60,000 \times Q)}{(d \times q_{\text{inj}} \times c_p)} \quad (\text{F.13})$$

F.2.4.4 Formula—with Heat Soak

The differential temperature, ΔT (in Kelvin), including the effects of heat soak can be calculated using the inputs described above and the following equation:

$$\Delta T = 60,000 \times \frac{(Q + Q_{\text{heatsoak}})}{(d \times q_{\text{inj}} \times c_p)} \quad (\text{F.14})$$

F.2.4.5 Example Calculation (Without Heat Soak)

- $Q = 0.9 \text{ kW (1.2 HP)}$
- $q_{\text{inj}} = 11 \text{ L/min (2.905 GPM)}$
- $d = 0.75$
- $c_p = 2300 \text{ J/kg} \cdot \text{K (0.549 BTU/lb} \cdot \text{°F)}$

Equation (F.13) gives:

$$\Delta T = \frac{(60,000 \times 0.9)}{(0.75 \times 11 \times 2300)} = 2.8 \text{ K (2.8 °C) (5 °F)}$$

F.2.5 Seal Flush Flow Rate

F.2.5.1 General

In some applications, it is necessary to specify the flush rate required to maintain the seal chamber temperature below a certain level. In this case, the maximum allowable temperature rise would be calculated by subtracting the maximum allowable temperature in the seal chamber (or buffer/barrier seal chamber) from the flush liquid temperature. For good seal performance, the maximum temperature rise should be limited to 5.6 °C (10 °F) (5.6 K) for Arrangement 1 and Arrangement 2 inner seal flush flow rates and 16 °C (30 °F) (16 K) for Piping Plan 23 and buffer/barrier flow rates (see 7.2.3.1 and 7.3.3.1). It is then a simple matter of rearranging Equations (F.10), (F.11), and (F.12) to solve for the required flush flow rate.

The temperature rise used in these calculations is the sealing chamber temperature rise. The temperature rise at the seal faces will be greater than the chamber temperature rise. If Equations (F.13) and (F.14) are used to calculate a minimum flow rate based on sealing chamber temperature, the seal faces can overheat and perform poorly. Depending on the service a design factor of at least two may need to be applied to the calculated required minimum flow rate. The injection shall also be directed at the seal interface to ensure proper cooling.

F.2.5.2 Seal Flush Flow Rate Calculation Inputs for Arrangement 1 and Arrangement 2

- Q is the heat generation at the seal faces, expressed in kilowatts;
- Q_{heatsoak} is the heat transferred from the pump and pumped process fluid to the fluid in the seal chamber, expressed in kilowatts;
- ΔT is the desired differential temperature, typically a minimum of 5.6 K (5.6 °C) (10 °F), expressed in (in degrees Kelvin);
- d is the relative density (specific gravity) of the injected fluid at the temperature of the seal chamber inlet;
- c_p is the specific heat capacity of the injected fluid at the temperature of the seal chamber inlet, expressed in joules per kilogram Kelvin.

F.2.5.3 Seal Flush Flow Rate Formula

F.2.5.3.1 General

For flush flow in liters per minute without heat soak typical for seals with Piping Plan 11, 12, 13, or 31, the equation would be:

$$q_{\text{inj}} = \frac{(60,000 \times Q)}{(d \times \Delta T \times c_p)} \quad (\text{F.15})$$

For flush flow in liters per minute with heat soak typical for seals with Piping Plan 21, 22, 23, 32, or 41, the equation would be:

$$Q_{\text{inj}} = 60,000 \times \frac{(Q + Q_{\text{heatsoak}})}{(d \times \Delta T \times c_p)} \quad (\text{F.16})$$

F.2.5.3.2 Seal Flush Flow Rate Example Calculation (Arrangement 1 Without Heat Soak)

$$Q = 0.9 \text{ kW (1.2 HP)}$$

$$\Delta T_{\text{max}} = 5.6 \text{ K (5.6 °C) (10 °F)}$$

$$d = 0.90$$

$$c_p = 2593 \text{ J/kg}\cdot\text{K} \text{ (0.619 BTU/lb}\cdot\text{°F)}$$

Equation (F.15) gives:

$$q_{inj} = (60,000 \times 0.9)/(0.9 \times 5.6 \times 2593) = 4.1 \text{ L/min (1.083 gal/min)}$$

F.2.5.3.3 Seal Flush Flow Rate Example Calculation (Arrangement 1 Without Heat Soak)

$$Q = 0.9 \text{ kW (1.2 HP)}$$

$$\Delta T_{max} = 5.6 \text{ °K (5.6 °C) (10 °F)}$$

$$d = 0.90$$

$$c_p = 2593 \text{ J/kg}\cdot\text{K} \text{ (0.619 BTU/lb}\cdot\text{°F)}$$

Equation (F.15) gives:

$$q_{inj} = (60,000 \times 0.9)/(0.9 \times 5.6 \times 2593) = 4.1 \text{ L/min (1.083 gal/min)}$$

F.3 Piping Plan 52, 53A, and 53B Systems

F.3.1 Auxiliary System Design and Friction Curves

F.3.1.1 General

Buffer/barrier seal chamber generated heat and appropriate flush flow for Piping Plan 52 and Plan 53A seal systems are particularly unique because they usually utilize an internal circulating device, the buffer/barrier fluid circulates through the reservoir, and the exchanger would be internal to the reservoir. Estimated system friction curves are included in this section for Piping Plan 52 and Plan 53A. These system curves represent piping losses and do not include losses through porting in the gland plate or other components.

Unlike Piping Plan 52 and Piping Plan 53A, Piping Plan 53B and Piping Plan 53C may utilize an external exchanger and the circulating flow does not pass through the accumulator. There would be a significant increase in system friction if losses through an external exchanger are added to the interconnecting piping losses.

Performance curves for the internal circulating devices used with any Piping Plan 52 or Piping Plan 53 will vary depending on the type and design of device, the operating clearance, the gland plate design, fluid properties, and the peripheral velocity. As a result, the specific device performance curve should be overlaid on the Piping Plan 52 or Piping Plan 53 A/B/C system curve to determine the appropriate interconnecting pipe/tube size so the desired flow will be achieved. Refer to Section 8 for recommended tube and pipe sizes. When there is any doubt about these parameters, 20 mm (0.75 in.) pipe or tubing should be used because, as can be seen in the systems curves below, friction losses are minimized. An analysis of the parameters would determine that an increase to a 25 mm (1 in.) pipe offered little benefit. While not modeled, whenever possible the purchaser should consider tangential oriented buffer/barrier fluid gland plate connections to improve flush flow rates.

While selected less frequently than internal circulating devices, seal vendors can also offer an external circulating pump to ensure that the desired flush flow is achieved.

This subsection provides the background behind the pipe size recommendations in this standard and describes how a seal vendor might analyze and check the performance of a Piping Plan 52 or 53A system. Illustrative diagrams are shown.

Piping Plan 52 and 53 A seal systems have been modeled with standardized stub pipes with lap joints to the gland plate. The length of the stub pipe has been assumed at 150 mm (6 in.), as shown in Figure F.6. The stub pipe material has been assumed as $\frac{1}{2}$ in. Schedule 80 pipe irrespective of whether the main circuit is constructed of pipe or tube.

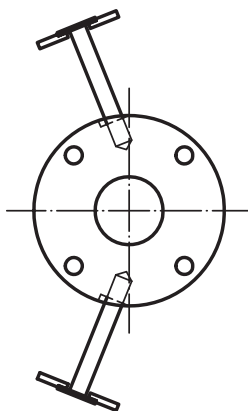

Figure F.6—Gland Plate Model

Fluid properties used to generate the system curves are:

- water with a specific gravity of 0.9983 at 20 °C (68 °F) and viscosity of 0.1 MPa·s (1 cP);
- oil with a specific gravity of 0.85 at 20 °C (68 °F) and viscosity of 10 MPa·s (10 cP);
- maximum flush flow rate is assumed to be 1.2 m³/h (5 U.S. gal/min).

The general model used for the barrier fluid system is as shown in Figure F.7. The interconnecting piping to and from the reservoir has been assumed to be of equal length, and this has been set at 2.5 m per leg. The inlet to the gland plate is assumed to be from the lower pipe leg with an exit from the gland plate as the upper pipe leg (see Figure F.6).

The piping materials are either Schedule 80 pipe or tube. The diameter and bore used to calculate the system losses are shown in Table F.1.

Estimated system curves for the pipe work sizes shown in Table F.1 are illustrated in Figure F.8 and Figure F.9 for mineral oil and water. Tubing sizes and wall thickness can vary and the layout and length of piping will also vary between installations, so the curves in Figure F.8 and Figure F.9 should be used as a guideline rather than an exact reflection of a specific field installation.

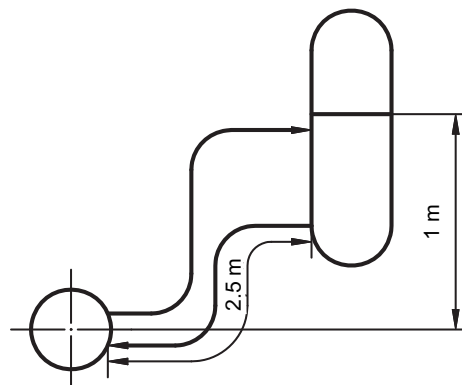

Figure F.7—System Model

Table F.1—Pipe and Tube Dimensions for System Loss Calculations

Diameter	Bore Mm	Bore (in.)
15 mm (0.5 in.) pipe	13.84	(0.546)
20 mm (0.75 in.) pipe	18.88	(0.742)
12 mm (0.5 in.) tube	9 ^a	(0.37) ^b
20 mm (0.75 in.) tube	16 ^c	(0.543) ^d

^a OD = 12 mm; wall thickness = 1.5 mm.
^b OD = 0.5 in.; wall thickness = 0.65 in.
^c OD = 20 mm; wall thickness = 2 mm.
^d OD = 0.75 in.; wall thickness = 0.095 in.

F.3.1.2 Pipe System Friction Curves

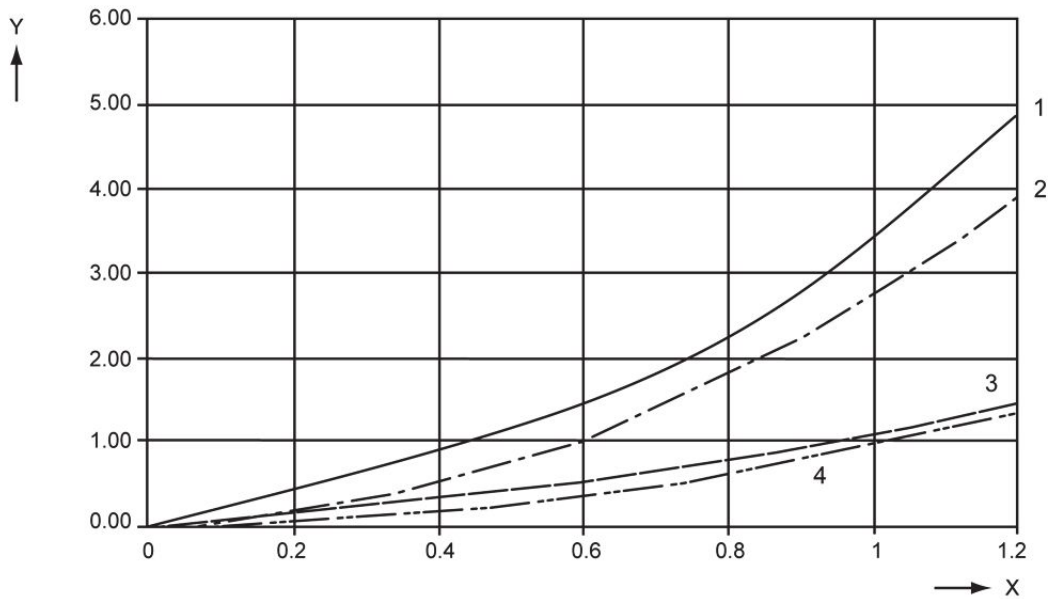

Key

- X flow, m³/h
- Y friction, m
- 1 15 mm mineral oil
- 2 15 mm water
- 3 20 mm mineral oil
- 4 20 mm water

Figure F.8—Pipe System Friction Curves

F.3.1.3 Tubing System Friction Curves

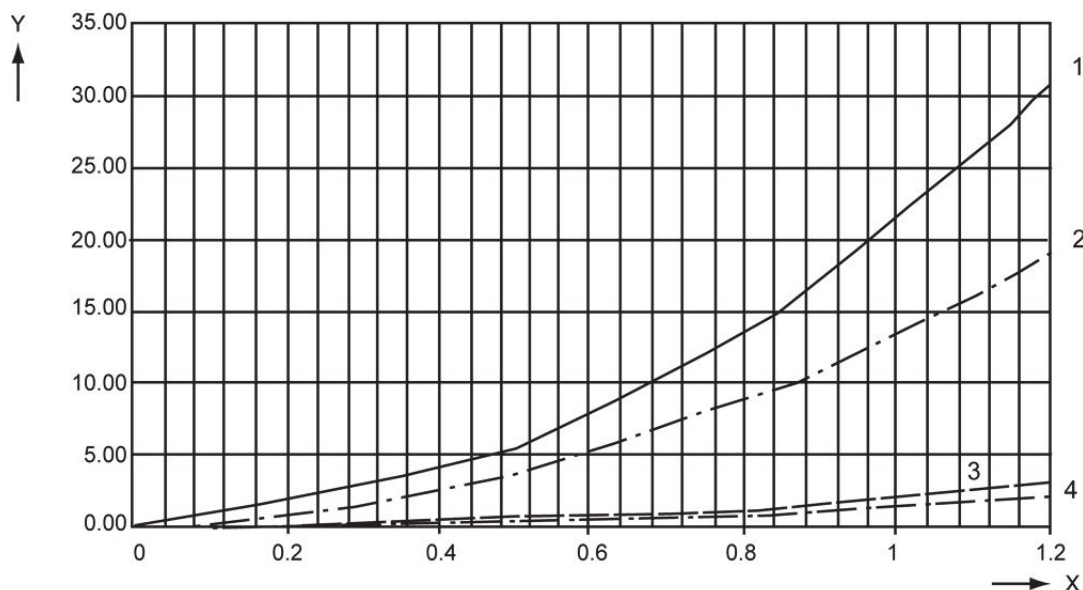

Key

X flow, m³/h

Y friction, m

1 12 mm mineral oil

2 12 mm water

3 20 mm mineral oil

4 20 mm water

Figure F.9—Tubing System Friction Curves

F.3.1.4 Internal Circulating Device Performance Verification

When an internal circulating device is used the seal vendor should evaluate its performance curve. The curve should illustrate head versus capacity and the vendor should also confirm that the NPSH(r) is satisfied over the entire flow range of the device. The device NPSH(r) may be represented by a curve or data. Users should carefully review applications using an internal circulating device, but especially when:

- the process fluid temperature exceeds 176 °C (350 °F);
- the shaft rotating speed is equal to or less than 1800 r/min;
- variable speed drives are used;
- shaft diameter is less than 50 mm (2 in.);
- the total length of interconnecting pipework exceeds 5 m (16.4 ft);
- a radial clearance smaller than that specified in 6.1.2.6. is proposed to achieve the required flush flow rate.
- the viscosity of the circulating fluid varies significantly because of start-up, ambient, or process related temperature changes.

Performance of the internal circulating device should exceed the required flush flow using the specified buffer/barrier fluid at all operating and start up conditions. The system resistance curve (based on the auxiliary components supplied, the specific buffer/barrier fluid, its mean settlement temperature, and the specific seal system layout) should be plotted over the circulating device performance curve. Typical system resistance curves are provided in F.3.1.2 and F.3.1.3 for Piping Plan 52 and Piping Plan 53 tube and pipe systems approximating construction in accordance with G.32.

Piping Plan 23 seal systems will likely have steeper system resistance curves compared to Piping Plan 52 or Piping Plan 53 systems because of the additional system resistance of the heat exchanger. Piping Plan 23 systems typically utilize heat exchangers with the process fluid inside the exchanger tubing.

Depending on the seal ring orientation and space available on some seal designs with a Piping Plan 23 use of a distributed flush may not be advisable if the added resistance of the flush geometry detrimentally impacts the flush flow velocity. In these circumstances consult the seal manufacturer for detailed information on the evidence for achieving reliable operation without a distributed flush.

To improve flush flow circulation rates, inlet and outlet connections for the internal circulating device should be tangential and oriented to facilitate thermosyphon as illustrated in Figure G.33. In addition, the seal chamber or gland plate inlet and outlet ports should properly align with the internal circulating device and their drill-through diameters designed as large as is practical.

Figure F.10 and Figure F.11 illustrate the intersection points between a hypothetical circulating device performance curve(s) and the system curves. These intersection points indicate the estimated comparative flow that can be achieved with each combination of pipe and tube size and mineral oil or water buffer/barrier systems. Please note:

- a) performance data for the circulating device is identical for the tubing and pipe plots;
- b) the values for the flow axis are identical;
- c) the values for the head axis are identical;
- d) variations in the resulting intersection points are solely the result of differences in the system curves created by combinations of fluid with different size pipe or tubing.

Figure F.10 and Figure F.11 also show the system resistance in tubing systems is normally significantly higher than pipe systems for the same fluid, nominal size, and flow rate producing steeper tube system curves. As a result, the performance curves intersect the tubing system curves at a lower flow compared to the same nominal size pipe. The user should be aware that the highest flush rate is achieved with an interconnecting pipework selection of pipe and with a size selection of 20 mm.

F.3.2 Typical Flush Flow Rates for Arrangement 3CW Seals

Figure F.12, Figure F.13, Figure F.14, and Figure F.15 are typical required flush flow rates for Arrangement 3CW seal, pressurized dual contacting wet seals, graphically illustrated. The curves are based on:

- a) a barrier fluid specific heat C_p of 2093 J/Kg·°K (0.5 BTU/lb °F);
- b) shaft speed 3600 r/min;
- c) balance ratio of 0.75;
- d) a flush flow temperature rise of 8 °C (15 °F);
- e) seal chamber pressure of 1.034 MPa (10.034 bar) (150 psig);

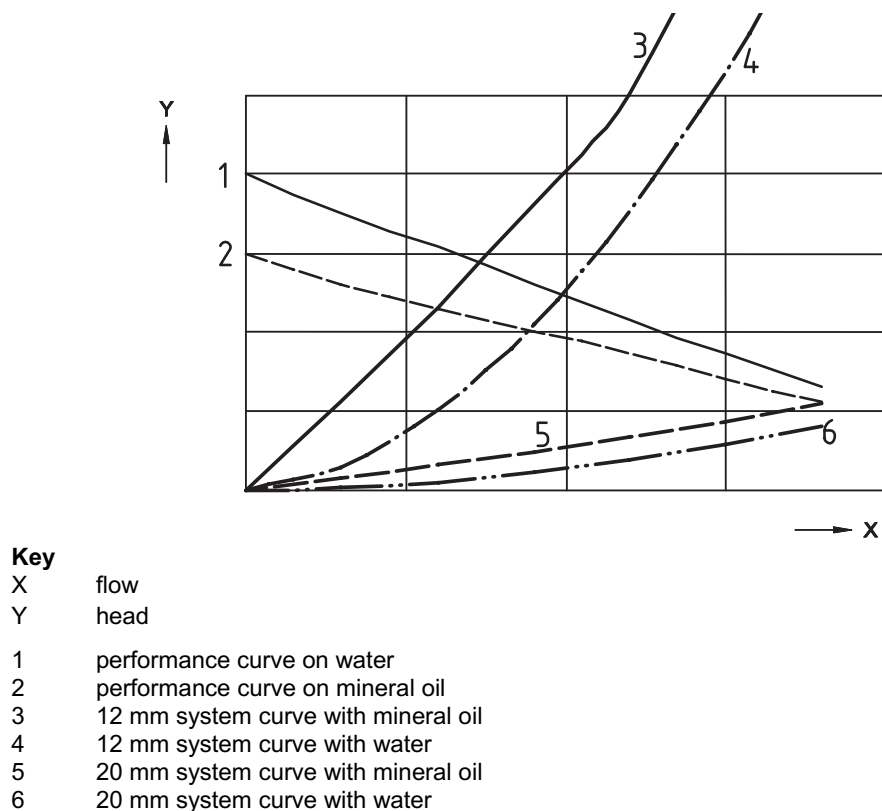

Figure F.10—Circulating Device Performance and System Resistance in Tubing System Curves

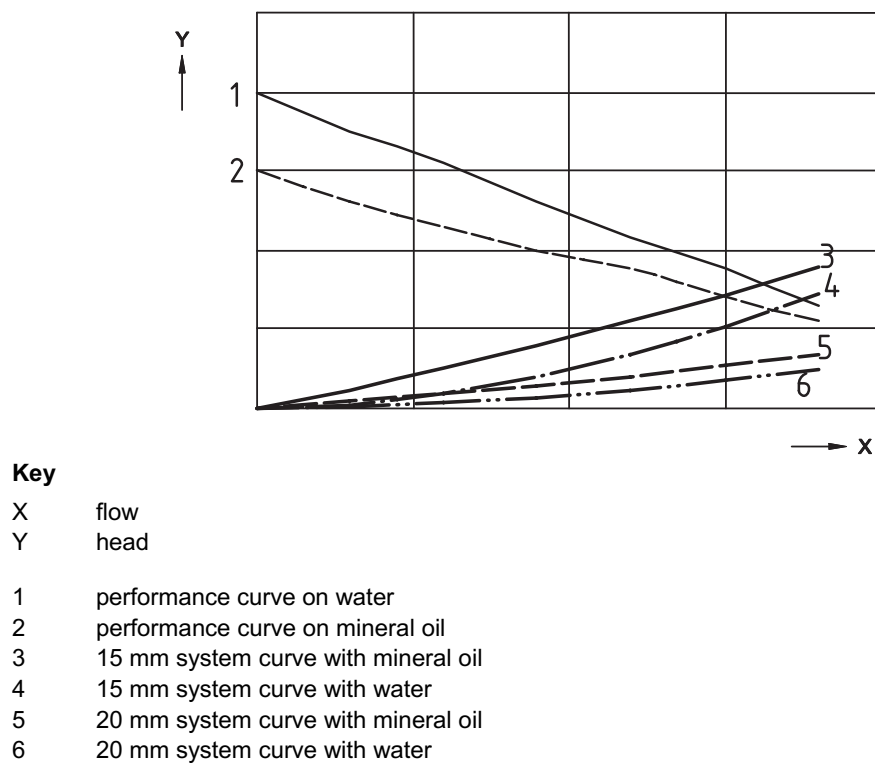
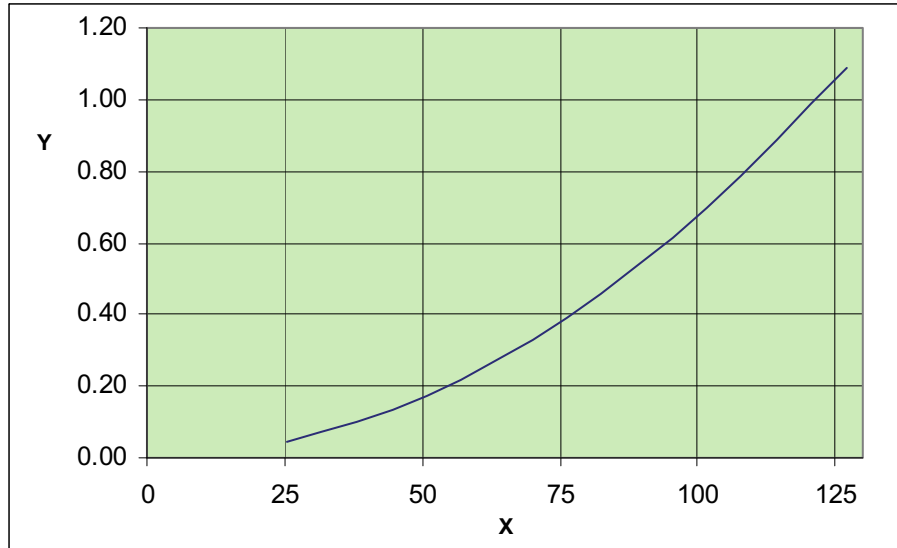
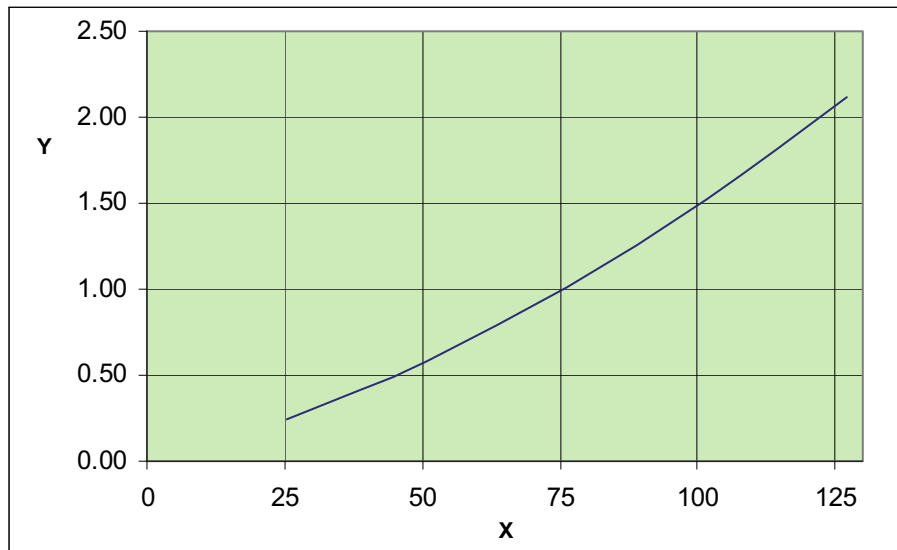

Figure F.11—Circulating Device Performance and System Resistance in Pipe System Curves

**Key**

X seal mean diameter, mm
 Y flow, m³/h

Figure F.12—Typical Required Flush Flow for Arrangement 3 CW Seals Without Heat Soak Considered and a Pumped Fluid Temperature of 54 °C (130 °F)

**Key**

X seal mean diameter, mm
 Y flow, m³/h

Figure F.13—Typical Required Flush Flow for Arrangement 3 CW Seals with Heat Soak Considered and a Pumped Fluid Temperature of 176 °C (350 °F)

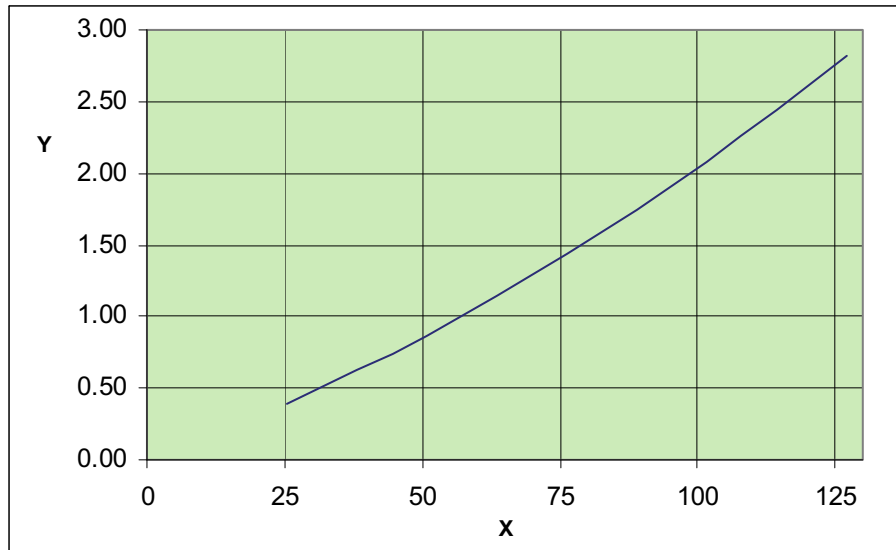
**Key**

X seal mean diameter, mm

Y flow, m³/h

Figure F.14—Typical Required Flush Flow for Arrangement 3 CW Seals with Heat Soak Considered and a Pumped Fluid Temperature of 260 °C (500 °F)

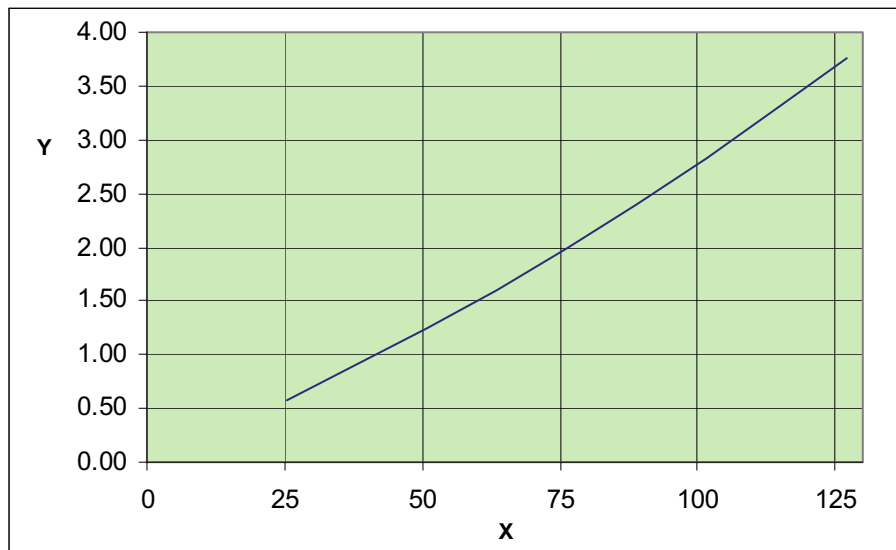
**Key**

X seal mean diameter, mm

Y flow, m³/h

Figure F.15—Typical Required Flush Flow for Arrangement 3CW Seals with Heat Soak Considered and a Pumped Fluid Temperature of 371 °C (700 °F)

- f) barrier fluid pressure of 1.379 MPa (13.79 bar) (200 psig);
- g) a safety factor for flush flow of 1.0.

NOTE 1 7.3.3.1 requires a maximum flush flow temperature rise of 8 °C (15 °F) or 16 °C (30 °F) depending on the barrier fluid type.

NOTE 2 For barrier fluids with a different specific heat, divide the predicted graph flow rate by the C_p ratio [actual barrier C_p divided by 2093 J/Kg·K (0.5 BTU/lb °F)].

While curves are provided for pumped fluid temperatures above 176 °C (350 °F), achieving an adequate flow using an internal circulating device for higher temperature applications becomes increasingly difficult and a Piping Plan 54 or external circulating device may be required for these services.

F.3.3 Piping Plan 53A and 53B Barrier Pressure and Operation

F.3.3.1 General

Piping Plans 53A and 53B provide barrier liquid to Arrangement 3 dual seals at a pressure above the maximum (process pumped fluid) seal chamber pressure by using a gas charged 53A reservoir or 53B accumulator. Piping Plan 53C also provides a pressure margin above the maximum seal chamber pressure, but it is achieved by using a reference line from the seal chamber and a piston accumulator rather than a gas charged reservoir or accumulator. Pressure variations in Piping Plans 53A and 53B can be significant, so these piping plans are covered in detail in this section. Piping Plan 53C pressure fluctuations are minimal and are not covered in this standard.

The maximum process fluid seal chamber pressure may vary for a variety of reasons such as pump design, static liquid level, and pressure relief setting on the suction vessel. It is important that the maximum suction pressure be reviewed and confirmed prior to starting the calculation of the gas charge pressure for either Piping Plan 53A or 53B.

The minimum barrier liquid pressure will normally include a pressure margin above the maximum seal chamber pressure to avoid a pressure reversal across the inner seal. A typical pressure margin may be 0.14 MPa (1.4 bar) (20 psi), but can be higher or lower in some circumstances.

When properly selected the Piping Plan 53A barrier reservoir pressure or the Piping Plan 53B accumulator gas charge pressure will avoid a pressure reversal at the inner seal and also avoid overpressurizing the seal or seal flush system components due to liquid volume changes and seasonal or diurnal fluctuations in ambient temperature or solar radiation exposure.

Category 1 seal and seal flush system components are rated for a minimum gauge pressure of 2 MPa (20 bar) (300 psi). Category 2 and 3 seal and seal-flush system components are rated for a minimum gauge pressure of 4 MPa (40 bar) (600 psi). Some seals may have a pressure rating lower than their associated flush system components. It is important to verify the pressure rating of seals and associated flush system components and confirm that pressure fluctuations do not exceed these ratings. For example, Type B or Type C seals typically have lower differential pressure rating than Type A seals. Some dual seal configurations may utilize the pump seal chamber as part of the barrier liquid system so the pump seal chamber would need to be considered in the pressure evaluation.

With both Piping Plans 53A and 53B, as barrier fluid pressure increases seal face related friction also increases. Users should be aware that it may become difficult or impossible to rotate some pumps prior to start-up when the seal is pressurized. In small pumps, seal face friction may also contribute significantly to the motor load and it is possible to experience an overload condition (high amps) causing shutdown of a marginally sized motor.

Circulation of barrier liquid at required flow rates is important for seal reliability. Refer to F.3.1.2, F.3.1.3, F.3.1.4, and F.3.2 for discussion on internal circulation device performance.

F.3.3.2 Piping Plan 53A Operation

F.3.3.2.1 General

Figure G.18 illustrates a typical Piping Plan 53A system. The barrier liquid reservoir is pressurized by an outside source, typically the plant nitrogen system, another plant gas source or bottled gas. A pressure regulator should be installed upstream of the gas supply isolation valve, but the pressure regulator is not normally in the scope of supply of the pump or seal vendor and hence is not shown in Figure G.18. However, to avoid a release of potentially hazardous gas, the pressure regulator is not normally self-relieving.

When the source of gas for pressurizing the reservoir is bottled gas, the user may want to consider the use of a low-pressure alarm on the gas bottle, upstream of the pressure regulator, for early indication of the need to replace the gas bottle. This low-pressure alarm is not normally in the scope of supply of the seal or pump vendor.

The minimum barrier liquid pressure and the set point for the pressure regulator is the maximum seal chamber pressure plus a pressure margin. However, the reservoir pressure may vary because of liquid volume changes or diurnal and seasonal ambient temperature changes, changes in barrier liquid temperature, and/or solar radiation exposure (if applicable).

The barrier liquid in a Piping Plan 53A system circulates through the reservoir and the reservoir usually incorporates a cooler. Since the gas in the reservoir is exposed to the circulating barrier liquid, reservoir pressure variations are complicated by the influence of the barrier liquid on the gas temperature and gas solubility. During stable operation, it is reasonable to expect the barrier liquid temperature to reach equilibrium at a temperature above average ambient temperatures because of heat soak into the circulating barrier liquid due to an elevated process pumped liquid temperature and seal face generated heat from both seals.

It is unlikely that barrier liquid pressure will exceed the rated pressure of Category 2 or 3 systems if the charge gas supply is a plant nitrogen system that normally operates at or below a gauge pressure of 1 MPa (10 bar) (150 psi). This pressure is significantly below the minimum rating of Category 2 and 3 seals and flush system components. Pressure fluctuations due to diurnal or seasonal ambient temperature variations, barrier liquid temperature changes, or solar exposure will likely not exceed the pressure rating of Category 2 or 3 seals or flush system components. However, Category 1 seals and support systems are rated for lower pressure so it is important to verify that pressure fluctuations do not exceed component or support system ratings.

For charge gas supply systems that operate at a pressure above 1 MPa (10 bar) (150 psi) it is important to verify that pressure fluctuations do not exceed component or support system ratings for all seal categories.

If the gas supply isolation valve is closed between the barrier liquid reservoir and the pressure regulator / gas supply system, it is possible to experience a drop in reservoir pressure caused by either a drop in ambient temperature, a drop in barrier liquid temperature, or a drop in reservoir level. With the gas supply isolation valve closed, users should consider the impact of ambient temperature extremes and changes in barrier liquid temperature on reservoir pressure. Failure to do so may result in a pressure reversal across the inner seal. Figure G.18 shows this valve as normally open to avoid this scenario.

Barrier liquid level will drop because of seal leakage. The need to add barrier liquid to the reservoir occurs when the operating volume of barrier liquid is used. A level indicator and level transmitter with a low-level alarm are provided on Piping Plan 53A systems to indicate the need to add barrier liquid. Filling frequencies are similar to those required by 53B systems and the minimum period between fills is stated in 8.3.6.1.6.

In addition to a level transmitter, Piping Plan 53A systems are also provided with a pressure transmitter. As a minimum, a low alarm set point is required for level and pressure; however, a high alarm set point for each is optional.

Figure F.16 illustrates a Piping Plan 53A system for a reservoir continuously connected to the gas supply, typically through a pressure regulator that is not self-relieving. The associated calculations are consistent with the figure. It is reasonable to expect an increase in reservoir pressure caused by exposure to maximum ambient temperature, an elevated barrier liquid temperature, and/or solar radiation. The graph and associated calculations assume the reservoir gas temperature reaches the maximum ambient, maximum barrier liquid temperature, and solar radiation temperature. During stable operation, the gas temperature fluctuations may be minimized because of exposure to the barrier fluid as it flows through the reservoir. Also, any unsafe pressure rise may be limited if the pressure regulator is self-relieving or if a relief valve is installed; however neither of these is included in a typical Plan 53A system.

Figure F.16 illustrates important calculation points for Piping Plan 53A systems. Refer to F.3.3.2.2 for a detailed description of each plotted point.

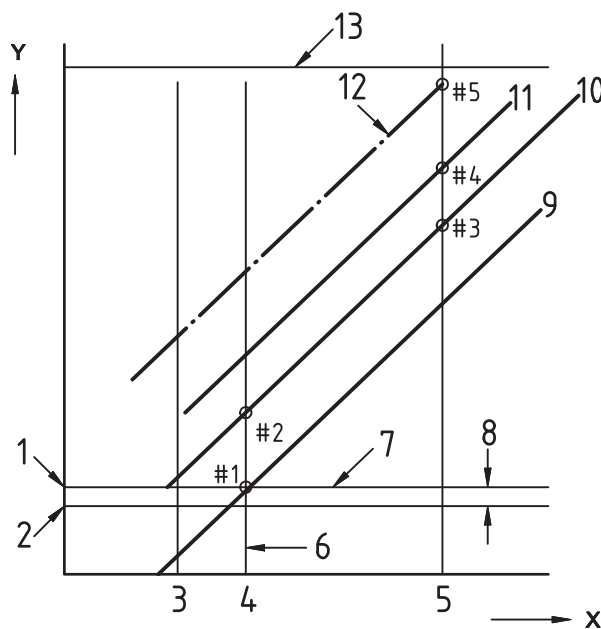

Key

- X Piping Plan 53A barrier liquid level
- Y accumulator/barrier liquid pressure
- 1 minimum barrier liquid pressure
- 2 maximum seal chamber pressure
- 3 empty
- 4 minimum
- 5 maximum
- 6 low level alarm
- 7 low pressure alarm
- 8 additional pressure margin
- 9 minimum ambient temperature
- 10 maximum ambient temperature
- 11 maximum barrier liquid temperature
- 12 solar temperature
- 13 MAWP limit of seal or seal support system

Figure F.16—Calculation Points for Piping Plan 53A Systems

The initial charge of barrier liquid is normally added prior to pressurizing the reservoir. Most systems have a pressure regulator that will be set at the minimum barrier system pressure so the barrier system pressure will not fall below this value. If the ambient temperature drops causing a drop in reservoir pressure or the liquid level drops the gas supply regulator will add gas to maintain the specified pressure. If the regulator is not self-relieving the barrier system pressure may increase because of diurnal variations in ambient temperature, changes in barrier liquid temperature, and any subsequent refill liquid volume additions.

F.3.3.2.2 Piping Plan 53A Calculation Tutorial and Formula

The following discussion refers to the illustrated “numbered” points in Figure F.16.

Point #1—Minimum barrier liquid pressure at minimum liquid level—This pressure is the basis for all subsequent calculations and is the sum of the maximum seal chamber pressure and a pressure margin and is the set point for the pressure regulator. For the purposes of the following calculations, this pressure is assumed to be at the minimum ambient temperature because it is normally maintained by a pressure regulator. It is also the recommended alarm pressure.

Point #2—Calculates the reservoir pressure using the value of Point #1, but applies a ratio of maximum ambient temperature and minimum ambient temperature.

$$\text{Point \#2 Pressure} = \text{Pressure at Point \#1} \times (\text{maximum ambient temp } (^{\circ}\text{C} + 273) \text{ (or; } ^{\circ}\text{F} + 460) / [\text{minimum ambient temp } (^{\circ}\text{C} + 273) \text{ (or; } ^{\circ}\text{F} + 460)]).$$

Point #3—Calculates the reservoir pressure using the value of Point #2, but applies a ratio of maximum gas volume (at minimum barrier liquid level) and minimum gas volume (maximum barrier liquid level).

$$\text{Point \#3 pressure} = \text{Pressure at Point \#2} \times \text{maximum gas volume} / \text{minimum gas volume}$$

Point #4—Calculates the reservoir pressure using the value at Point #3, but applies a ratio of maximum barrier liquid temperature and maximum ambient temperature.

$$\text{Point \#4 pressure} = \text{Pressure at Point \#3} \times (\text{maximum barrier liquid temp } (^{\circ}\text{C} + 273) \text{ (or; } ^{\circ}\text{F} + 460) / [\text{maximum ambient temp } (^{\circ}\text{C} + 273) \text{ (or; } ^{\circ}\text{F} + 460)]).$$

Point #5—Calculates the reservoir pressure using the value of Point #3, but applies a ratio of solar radiation temperature and maximum ambient temperature.

$$\text{Point \#5 pressure} = \text{Pressure at Point \#3} \times \text{solar radiation temp } (^{\circ}\text{C} + 273) \text{ (or; } ^{\circ}\text{F} + 460) / [\text{maximum ambient temp } (^{\circ}\text{C} + 273) \text{ (or; } ^{\circ}\text{F} + 460)].$$

F.3.3.2.3 Piping Plan 53A Example Calculation

The example calculation is for a Piping Plan 53A application showing the effects of solar radiation. The example seal support system is designed for a gauge pressure of 4 MPa (40 bar) (600 psi) typical of Category 2 and 3 seal systems.

Assumptions include site conditions:

- maximum site temperature is 40 °C;
- minimum site temperature is –10 °C;
- maximum barrier liquid temperature is 68 °C;
- maximum solar radiation temperature is 80 °C.

Seal system assumptions:

- total reservoir volume is 20 L;
- reservoir gas volume at minimum barrier liquid level (10 L of barrier liquid in reservoir) is 10 L;
- reservoir gas volume at maximum barrier liquid level (14 L of barrier liquid in reservoir) is 6 L;
- maximum seal chamber pressure is 0.7 MPa (ga) [0.8 MPa (abs)];
- pressure margin above maximum seal chamber pressure is 0.14 MPa.

Step 1: Determine the minimum operating reservoir pressure at minimum liquid level assuming minimum ambient temperature.

$$\text{Point \#1} = 0.8 + 0.14 = 0.94 \text{ MPa (abs) [0.84 MPa (ga) (122 psig)]}$$

NOTE This value represents the low-pressure alarm pressure.

Step 2: Calculate the corresponding reservoir pressure at maximum ambient temperature and minimum barrier liquid level.

$$\text{Point \#2} = 0.94 \times (40 + 273) / (-10 + 273) = 1.119 \text{ MPa (abs) [1.019 MPa (ga) (148 psig)]}$$

Step 3: Calculate the corresponding reservoir pressure at the maximum barrier liquid level and maximum ambient temperature.

$$\text{Point \#3} = 1.119 \times 10 / 6 = 1.865 \text{ MPa (abs) [1.765 MPa (ga) (256 psig)]}$$

Step 4: Calculate the corresponding reservoir pressure at the maximum barrier liquid level and temperature.

$$\text{Point \#4} = 1.865 \times (68 + 273) / (40 + 273) = 2.032 \text{ MPa (abs) [1.932 MPa (ga) (280 psig)]}$$

Step 5: Calculate the corresponding reservoir pressure at the solar radiation temperature.

$$\text{Point \#5} = 1.865 \times (80 + 273) / (40 + 273) = 2.103 \text{ MPa (abs) [2.003 MPa (ga) (290 psig)]}$$

F.3.3.3 Piping Plan 53B Operation

F.3.3.3.1 General

Figure G.19 illustrates a typical Piping Plan 53B system. The barrier liquid is pressurized using a gas charge inside a bladder within the accumulator. Unlike a typical Piping Plan 53A system, after a Piping Plan 53B accumulator is charged to a predetermined gas pressure, the accumulator is then isolated from the gas source during operation.

Accumulator pressure will drop because of seal leakage and reduced barrier liquid volume. Knowing the expected rate of seal leakage (determined by empirical data or estimated by the seal vendor) and the operating volume of barrier liquid the frequency of refilling the accumulator with barrier liquid can be determined. It is reasonable to expect a minimum filling frequency of twenty-eight days (28 d) as specified in 8.3.6.1.6, but this design prediction is dependent on the volume of barrier liquid, the leakage rate and the alarm strategy employed.

Accumulator pressure will also be affected by the gas temperature in the bladder. The barrier liquid does not flow through the accumulator, so the bladder gas temperature will change with ambient temperature (and

solar exposure if not shaded). Accumulator pressure variations can be significant. Accumulator gas charge pressure should consider the extremes of ambient temperature and the temperature during commissioning the system in a manner similar to that described for 53A systems. Failure to do so may result in a pressure reversal across the inner seal or overpressurizing the seal or seal support system components.

The calculations that follow illustrate a method to determine the initial gas charge pressure to avoid problems associated with variations in barrier liquid pressure. If the accumulator pressure at minimum liquid volume and minimum ambient conditions is equal to or greater than the maximum seal chamber pressure plus the pressure margin (Point #1 in Figure F.17 and Figure F.18, and Figure F.19), then it is assumed that the accumulator pressure will only increase at higher ambient temperatures and liquid volumes.

While most accumulators are exposed to atmospheric conditions, the affect of solar radiation can be eliminated by the use of a sun screen or shade. The impact of ambient temperature variations may be reduced if the accumulator is insulated or temperature controlled (i.e. heat traced). The user should verify that the seal and seal support system is suitable for all system pressures by following the calculation sequence illustrated in this annex.

The MAWP of Category 2 and 3 installations is significantly higher than Category 1, therefore it is reasonable to expect Category 1 installations may be more vulnerable to expected fluctuations in barrier liquid pressure.

Possible ways to limit the impact of local ambient temperature variations on accumulator pressure include:

- a) use of a larger accumulator;
- b) use of an engineered auxiliary system design that has an MAWP above standard Category 1, 2, or 3 systems;
- c) use of an engineered seal rated for higher pressure than standard Type A, B, or C seals;
- d) pressure relief valve in the barrier liquid piping;
- e) shade the accumulator to eliminate solar radiation effects;
- f) limit the impact of the ambient temperature range on the gas inside the accumulator by insulating and/or temperature control (heat tracing for example) of the accumulator.

Three descriptive phrases listed below are used to identify illustrated points in Figure F.17, Figure F.18, and Figure F.19, are referred to in the example calculations that follow, and are also used in Section 8.

- a) Accumulator minimum barrier pressure—This is the lowest operating barrier pressure and is equal to the sum of the maximum seal chamber pressure and a pressure margin, which is recommended to be a minimum of 0.14 MPa (1.4 bar) (20 psi). This establishes Point #1 in Figure F.17, Figure F.18, and Figure F.19. The value is used as a starting point for the example calculations in this annex. The pressure is temperature specific and the accumulator minimum barrier pressure will increase (between Point #1 and Point #7 in Figure F.17, Figure F.18, and Figure F.19) with increasing gas temperature in the bladder.
- b) Accumulator pressure range—This is the pressure range between the maximum and minimum barrier pressure and is specific to a temperature value. It is illustrated between Point #1 and Point #5 if a floating pressure alarm is utilized, but will be reduced to the pressure between Point #7 and Point #5 when a fixed pressure alarm strategy is utilized.
- c) Accumulator working liquid volume—This is the liquid volume in the accumulator released between the maximum barrier pressure and the alarm pressure. This is dependent on the alarm strategy applied. It is the liquid volume difference between maximum and minimum liquid barrier liquid volume if a floating

pressure alarm strategy is employed, but could be significantly less if a fixed pressure alarm strategy is used. Refer to Figure F.17. The selection of the accumulator sizes in this standard have been made to optimize the working liquid volume to be roughly equal to the working liquid volume for reservoir systems provided with Piping Plan 52 and 53A systems.

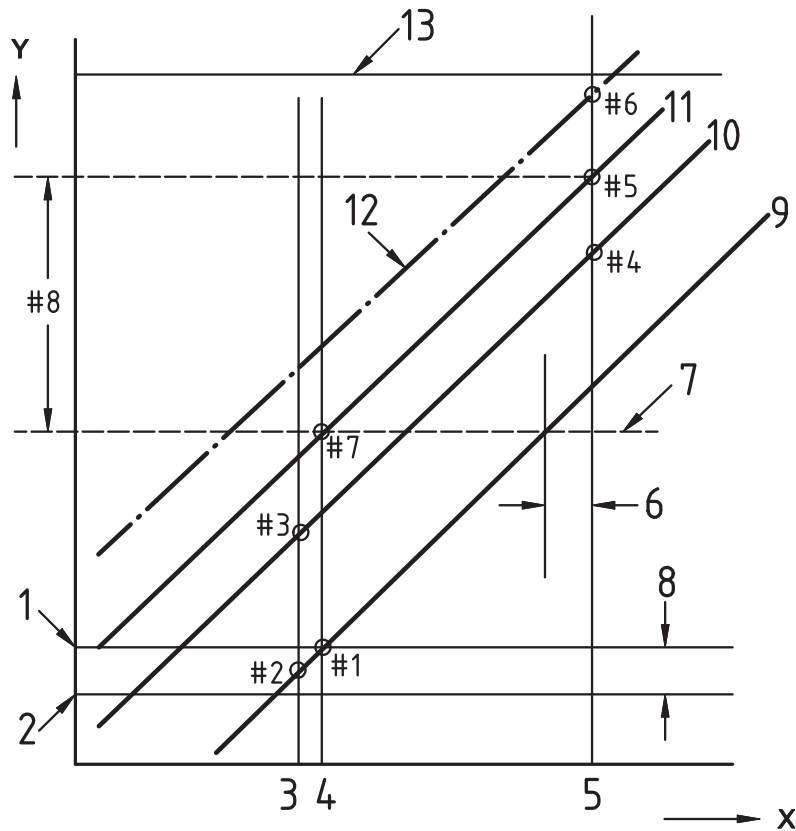

Key

- X barrier liquid volume
- Y accumulator/barrier liquid pressure
- 1 minimum barrier liquid pressure
- 2 maximum seal chamber pressure
- 3 empty
- 4 minimum
- 5 maximum
- 6 reduced working liquid volume
- 7 low pressure alarm
- 8 additional pressure margin
- 9 minimum ambient temperature
- 10 maximum ambient temperature
- 11 maximum barrier liquid temperature
- 12 solar temperature
- 13 MAWP limit of seal or seal support system

Figure F.17—Pressure Alarm Without Temperature Bias

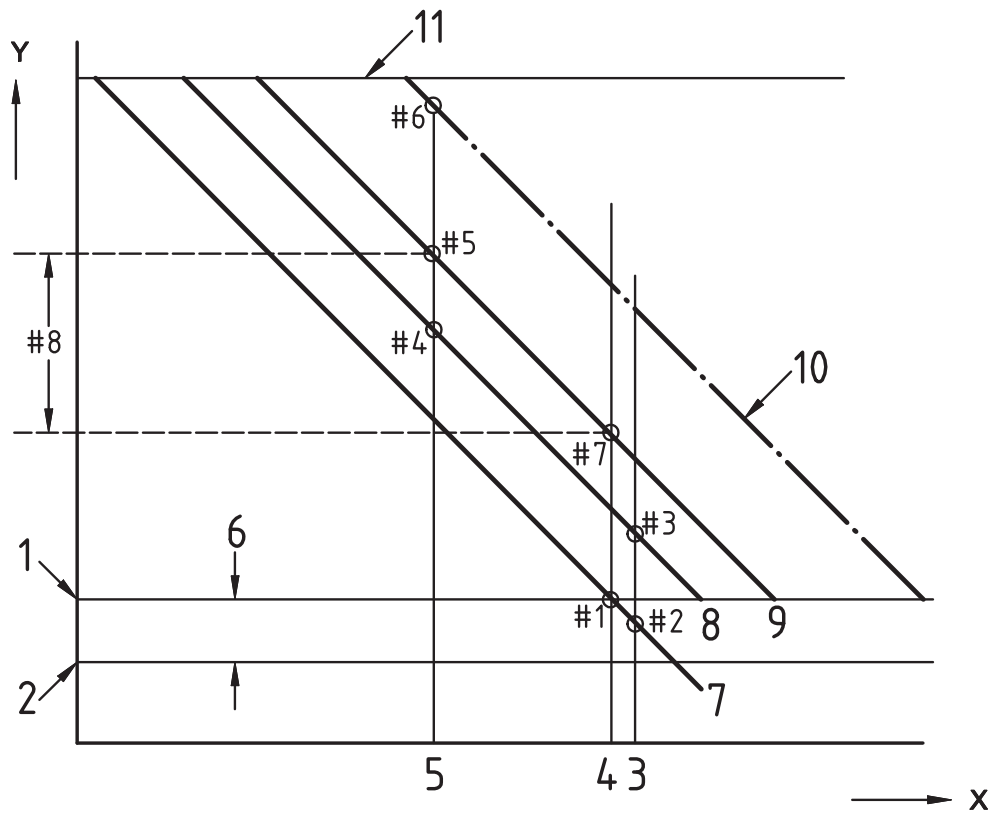
**Key**

- X accumulator gas volume
- Y accumulator/barrier liquid pressure
- 1 minimum barrier liquid pressure
- 2 maximum seal chamber pressure
- 3 empty accumulator (100 % gas volume)
- 4 minimum liquid volume
- 5 maximum liquid volume
- 6 additional pressure margin
- 7 minimum ambient temperature
- 8 ambient fill temperature
- 9 maximum temperature
- 10 solar radiation temperature
- 11 MAWP limit of seal or seal support system

Figure F.18—Barrier Liquid Pressure versus Accumulator Gas Volume

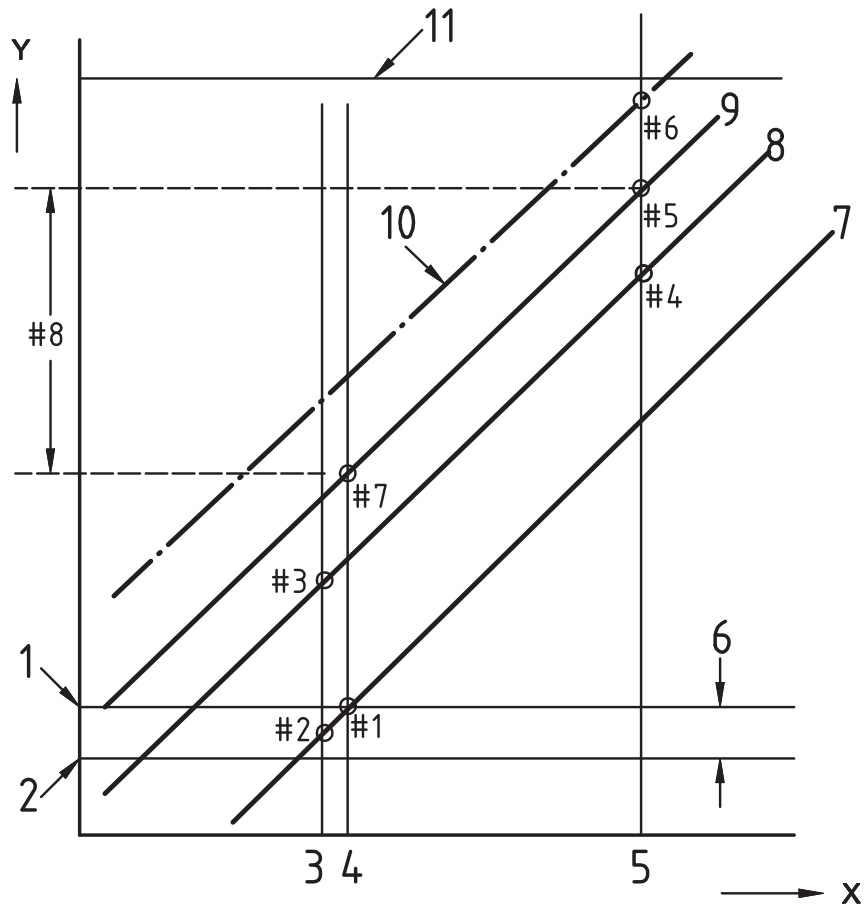
**Key**

- X barrier liquid volume
- Y accumulator/barrier liquid pressure
- 1 minimum barrier liquid pressure
- 2 maximum seal chamber pressure
- 3 empty
- 4 minimum
- 5 maximum
- 6 additional pressure margin
- 7 minimum ambient temperature
- 8 ambient fill temperature
- 9 maximum ambient temperature
- 10 solar temperature
- 11 MAWP limit of seal or seal support system

Figure F.19—Barrier Liquid Pressure Against Barrier Liquid Volume

F.3.3.3.2 Alarm Strategy and Accumulator Working Liquid Volume

The accumulator working liquid volume is dependent on many variables but should be optimized by the vendor to balance the accumulator working pressure range with the performance limits of the seal system, the desired minimum frequency of filling and the alarm strategy. The accumulator working liquid volume is typically 15 % to 25 % of the total accumulator volume.

Assuming a sunshade is fitted and the solar temperature need not be considered, the illustrated accumulator working pressure range (#8 in Figure F.18 and Figure F.19) represents the minimum pressure range, but may rise to the difference in pressure between Point #1 and Point #5 with a maximum ambient temperature change when a floating alarm strategy is utilized.

The graphs (Figure F.17, Figure F.18, and Figure F.19) illustrate important calculation points for Piping Plan 53B systems. The information presented in Figure F.18 and Figure F.19 is the same but presented from two different perspectives. Figure F.18 graphs barrier liquid pressure against accumulator gas volume whereas Figure F.19 graphs barrier liquid pressure against barrier liquid volume.

F.3.3.3.3 Fixed and Floating Alarm Strategies

The recommended pressure alarm for refilling Piping Plan 53B requires the use of a floating alarm set point (a pressure alarm with a temperature bias). The alarm set point is calculated continuously by the plant distributed control system (DCS) to actuate when barrier liquid volume reaches minimum liquid volume based on the temperature of the gas in the bladder (see 8.3.6.3.2). As can be seen in Figure F.18 and Figure F.19, the alarm pressure can vary between points #1 and #7 at minimum liquid volume.

A pressure alarm with a temperature bias provides a floating set point that is recommended because it will maximize the working liquid volume at all local ambient temperatures. It is accomplished by the use of a pressure and temperature transmitter (refer to Figure G.19) in the auxiliary seal system. These signals would be integrated into a plant DCS system to provide an accurate temperature adjusted pressure alarm set point. While using the plant DCS system may be the least costly approach for installations where a DCS is available, a local programmable logic controller (PLC) or single loop controller could also be used with this same alarm strategy (see 8.3.6.3.4).

Specific DCS input required for a floating alarm algorithm will include the minimum and maximum barrier liquid volume, the accumulator volume, and the accumulator minimum barrier pressure calculated at minimum ambient temperature. The vendor will use this data and the site ambient temperature data to optimize system design, minimize the frequency of refilling, and verify that the system design is suitable for the local installation.

Unlike a fixed alarm set point, a floating alarm set point can utilize the full potential liquid volume between minimum and maximum in the accumulator. The accumulator pressure range is also maximized, between Points #1 and Point #5 depending on the local ambient temperature change over the barrier pressure drop.

A fixed pressure alarm (without a temperature bias; see 8.3.6.3.4) utilizes a pressure transmitter or pressure switch with a low pressure setting at Point #7. This choice will, under most operating conditions, result in a significantly reduced accumulator working liquid volume. Figure F.17 illustrates a fixed alarm strategy. This alarm strategy does work and is commonly applied, but is operationally more restrictive than a floating pressure alarm.

It follows that if temperature fluctuations of the gas in the accumulator were substantially reduced or eliminated then working liquid volume associated with a fixed alarm system will approach that of a floating alarm system. However, the use of insulated accumulators or other temperature control methods on the accumulator has limited experience with Piping Plan 53B.

Figure F.17 shows the impact a single point alarm strategy has on the working liquid volume. When a single alarm strategy is employed, a fixed pressure value at Point #7 is required to provide an alarm corresponding to the minimum liquid volume at maximum ambient temperature. The choice of a lower fixed pressure value may risk the accumulator minimum liquid volume being reached at high ambient temperature without a warning alarm. When the barrier pressure value at maximum ambient temperature (Point #7) is considered at lower ambient (gas bladder) temperatures, the result is a reduced accumulator working barrier liquid volume. The operating pressure range is also reduced, between Point #7 and the maximum barrier pressure.

Refer to the calculations that follow in F.3.3.3.4 for a detailed description of each plotted point in Figure F.18 and Figure F.19. All figures assume solar radiation effects are eliminated by the use of a sunshade above the accumulator.

The information presented in Figure F.18 and Figure F.19 is the same, but presented from two different perspectives. Figure F.18 plots barrier liquid pressure against accumulator gas volume. Figure F.19 plots barrier liquid pressure against barrier liquid volume. The calculations that follow in F.3.3.3.4 refer to the points identified in these figures.

F.3.3.3.4 Piping Plan 53B Calculation Tutorial and Formula

The following discussion refers to the illustrated “numbered” points in Figure F.18 and Figure F.19. It assumes the accumulator bladder gas temperature corresponds to the local ambient temperature. To simplify the explanation the calculation also assumes the bladder precharge pressure is applied at the same ambient temperature prevailing when the system is initially filled with barrier liquid.

Point #1—Minimum barrier pressure at minimum barrier liquid volume and minimum ambient temperature. This pressure is the basis for all subsequent calculations and is the sum of the maximum seal chamber pressure and a pressure margin to avoid pressure reversals across the inner seal.

Point #2—Piping Plan 53B accumulator bladders are precharged with gas (usually nitrogen) when completely empty; Point #2 uses the value of Point #1 to determine the equivalent gas precharge pressure with an empty accumulator (zero liquid volume) if the local ambient temperature is also at a minimum.

Point #2 Pressure = Pressure at Point #1 × (gas volume at minimum liquid volume / total empty accumulator volume)

Point #3—Calculates the gas precharge pressure based on actual ambient temperature at the time of charging the accumulator bladder. Point #3 uses the value of Point #2, but applies a ratio of temperatures; ambient at the time of filling and minimum ambient temperature.

Point #3 pressure = Pressure at Point #2 × (ambient temp (°C + 273) (or; °F + 460) at time of filling / minimum ambient temp (°C + 273) [or; °F + 460])

NOTE The pressure at Point #3 is the value used to precharge the accumulator. When the gas charge reaches the prescribed pressure, it should be isolated and then the system should be prepared for adding barrier liquid. When the barrier liquid reaches the maximum liquid volume the pressure in the accumulator would reach the pressure at Point #4.

Point #4—Calculates the maximum barrier accumulator pressure with the maximum barrier liquid volume in the accumulator at the prevailing ambient temperature at the time of barrier liquid filling [assumes the same temperature as that used when precharging the bladder (refer to Point #3)]. Point #4 uses the value of Point #3, but applies a ratio of volumes; empty accumulator and gas volume with barrier liquid at the maximum volume.

Point #4 Pressure = Pressure at Point #3 × (total empty accumulator volume / bladder gas volume at maximum barrier liquid volume)

NOTE The bladder gas volume at maximum barrier liquid volume is a result of removing the volume between maximum and minimum barrier liquid volume values plus the minimum liquid volume (see 8.3.6.3.2) from the empty accumulator volume. The volume between maximum and minimum barrier liquid volume is normally estimated by the system design engineer and is an iterative value resulting from optimizing a balance between the maximum barrier pressure and accumulator working liquid volume (an initial value needs to be assumed and subsequently adjusted as appropriate).

Point #5—Calculates the maximum barrier pressure at maximum barrier liquid volume, but at the maximum ambient temperature. Point #5 uses the value of Point #4, but applies a ratio of temperatures; maximum ambient and ambient temperature at the time of precharging the bladder.

Point #5 Pressure = Pressure at Point #4 × maximum ambient temp (°C + 273) (or; °F + 460) / ambient temp (°C + 273) [or; (F + 460)] at time of filling

NOTE It is important the maximum barrier pressure at maximum ambient temperature does not exceed the dynamic sealing pressure rating (DSPR) of the seal or the MAWP of the system. The system designer, when considering the level of accumulator working volume may use the criteria below to ensure these limits are not exceeded.

Maximum barrier liquid volume shall be less than

$$V_{\text{tot}} - [(V_{\text{tot}} - V_{\text{min}}) * (T_{\text{max}}/T_{\text{min}})] \times [(p_{\text{cmax}} + 0.14) / (\text{Minimum of the DSPR or MAWP})]$$

where

V_{tot} is the total empty accumulator volume;

V_{min} is the minimum liquid volume (see 8.3.6.3.2);

T_{max} is the maximum absolute ambient temperature (K or °R);

T_{min} is the minimum absolute ambient temperature (K or °R);

p_{cmax} is the maximum absolute seal chamber pressure (MPa);

DSPR or MAWP in absolute pressure (MPa).

Point #6—Calculates the barrier pressure at maximum barrier liquid volume, but at the solar radiation temperature. Point #6 uses the value of Point #5, but applies a ratio of temperatures; solar radiation and maximum ambient temperature.

Point #6 Pressure = Pressure at Point #5 × [solar radiation temp (°C + 273) (or; °F + 460)] / [maximum ambient temp (°C + 273) (or; °F + 460)].

NOTE If the accumulator is shaded, insulated, or other means are used to limit the bladder gas temperature fluctuations this calculation step is not needed.

Points #7—This represents an alarm pressure set point. It corresponds to the barrier pressure at minimum liquid volume, but at maximum ambient temperature. Point #7 uses the value of Point #1, but applies a ratio of temperatures; maximum ambient and minimum ambient temperature.

Alarm pressure at Point #7 = Pressure at Point #1 × [maximum ambient temp (°C + 273) (or; °F + 460)] / [minimum ambient temp (°C + 273) (or; °F + 460)]

NOTE 1 If a fixed alarm strategy is chosen, the value calculated for Point #7 will be the recommended alarm pressure. If a floating alarm strategy is chosen then the value calculated for Point #7 represents the highest alarm pressure based on a calculated algorithm (see 8.3.6.3.4), but the alarm pressure will vary between Point #1 and Point #7 depending on the bladder gas temperature.

NOTE 2 It is important with a single alarm strategy that there is adequate accumulator working liquid volume to meet the requirement in 8.3.6.1.6 and the system designer may use the criteria below, combined with the criteria described in the Note specific to Point #5 to assist in selecting the performance limits of the system.

Maximum barrier liquid volume shall be less than:

$$V_{\text{tot}} - [(V_{\text{tot}} - V_{\text{min}}) * (T_{\text{min}} / T_{\text{max}})] + (\text{minimum level of accumulator working liquid volume})$$

where:

V_{tot} is the empty accumulator volume;

V_{min} is the minimum liquid volume (see 8.3.6.3.2);

T_{max} is the maximum absolute ambient temperature (K or °R);

T_{min} is the minimum absolute ambient temperature (K or °R).

F.3.3.3.5 Piping Plan 53B Example Calculation

The example calculation is for a Piping Plan 53B application showing the effects of local ambient temperature range and solar radiation. It is assumed that the auxiliary seal system is designed for a MAWP gauge pressure of 4 MPa (40 bar) (600 psi) typical of Category 2 and Category 3 seal systems and the seal dynamic seal pressure rating (DSPR) exceeds this limit.

Assumptions include site conditions:

- maximum site temperature is 40 °C;
- minimum site temperature is -10 °C;
- ambient temperature at time of precharging and filling is 20 °C;
- maximum solar radiation temperature is 60 °C.

Seal system assumptions:

- total accumulator volume (no barrier liquid) is 20 L;
- minimum barrier liquid volume is 0.2 L;
- maximum barrier liquid volume is 3 L;
- minimum acceptable accumulator working liquid volume is 1.5 L;
- maximum seal chamber pressure is 2 MPa (ga) [2.1 MPa (abs)];
- pressure margin above maximum seal chamber pressure is 0.14 MPa.

Step 1: Calculate the minimum barrier pressure at minimum liquid volume and minimum ambient temperature.

$$\text{Point \#1} = 2.1 + 0.14 = 2.24 \text{ Pa}$$

(a gauge pressure of 2.14 MPa) (21.4 bar) (310 psig)

NOTE 1 The following calculations will be utilizing absolute pressure values. The user should recognize that precharging and filling maintenance activities will normally utilize local gauge readings.

NOTE 2 If a fixed alarm strategy is chosen, this value calculated for Point #1 is only used as a basis for other calculations and is not an alarm pressure. If a floating alarm strategy is chosen then the value calculated for Point #1 represents the lowest alarm pressure based on a calculated algorithm (see 8.3.6.3.4) but the alarm pressure may vary between Point #1 and Point #7 depending on the bladder gas temperature.

Step 2: Calculate the corresponding accumulator bladder pressure assuming an empty accumulator (100 % gas volume) and minimum ambient temperature.

$$\text{Point \#2} = 2.24 \times (20 - 0.2 / 20) = 2.218 \text{ MPa (abs)}$$

Step 3: Calculate the corresponding accumulator bladder pressure assuming the ambient temperature at the time of filling and an empty accumulator (100 % gas volume). This is the field precharge gas (usually nitrogen) pressure.

$$\text{Point \#3} = 2.218 \times (20 \text{ °C} + 273) / (-10 + 273) = 2.471 \text{ MPa(abs) [2.371 MPa (ga) (344 psig)]}$$

Step 4: Calculate the corresponding maximum barrier pressure after the barrier liquid is added to the gas charged accumulator assuming both are completed at the same ambient temperature.

$$\text{Point \#4} = 2.471 \times (20 / 20 - 3) = 2.907 \text{ MPa (abs) [2.807 MPa (ga) (407 psig)]}$$

Step 5: Calculate the corresponding maximum barrier pressure at the maximum ambient temperature and at maximum barrier liquid volume.

$$\text{Point \#5} = 2.907 \times (40 \text{ °C} + 273) / (20 + 273) = 3.105 \text{ MPa (abs)}$$

NOTE Check the flexibility for increasing the maximum barrier liquid volume.

$$\text{Maximum barrier liquid volume} \leq 20 - ((20 - 0.2) \times [(40 + 273) / (-10 + 273)]) \times ((2.1 + 0.14) / 4.1) \leq 7.13 \text{ L}$$

The selected maximum barrier liquid volume of 3 L successfully meets the criteria and is in excess of the minimum acceptable accumulator working liquid volume of 1.5 L minimum acceptable accumulator working liquid volume.

Step 6: Calculate the corresponding barrier pressure at maximum barrier liquid volume but at the solar radiation temperature.

$$\text{Point \#6} = 3.105 \times (60 \text{ °C} + 273) / (40 + 273) = 3.303 \text{ MPa (abs)}$$

Step 7: Calculate the barrier alarm pressure setting corresponding to the pressure at minimum liquid volume and maximum ambient temperature.

$$\text{Point \#7} = 2.24 \times (40 + 273) / (-10 + 273) = 2.666 \text{ MPa (abs) [2.566 MPa (ga) (372 psig)]}$$

NOTE 1 If a fixed alarm strategy is chosen, the value calculated for Point #7 will be the recommended alarm pressure. If a floating alarm strategy is chosen then the value calculated for Point #7 represents the highest alarm pressure based on a calculated algorithm (see 8.3.6.3.4), but the alarm pressure may vary between Point #1 and Point #7 depending on the bladder gas temperature.

NOTE 2 Check the accumulator working liquid volume is suitable for a single alarm strategy.

$$\text{Maximum barrier liquid volume} \geq 20 - [(20 - 0.2) \times (-10 + 273) / (40 + 273)] + 1.5 \geq 4.86 \text{ L}$$

The selected maximum barrier liquid volume of 3 L does not meet the criteria. If a single alarm strategy is required the maximum liquid volume needs to be between 4.86 L and 7.13 L. This will change the calculation on Point #4 and Point #5 above and raise the maximum barrier pressures.

F.4 Cartridge Sleeve Drive Collar Set Screw Loading

A cartridge sleeve drive collar and set screws are required to manage the torque occurring at the seal face and the axial force derived from the seal chamber pressure acting across the process end of the seal sleeve. For most seal sizes and seal chamber pressures, the axial force is the critical design criteria, not the torque load on the set screws. The effective area at the sleeve end over which the seal chamber pressure acts for most seal arrangements is the area difference between the shaft and seal balance diameter.

The number, size, and type of set screw used to a drive mechanical seal sleeves will vary with sleeve and pump design, maximum seal chamber pressure, materials of construction, and seal configuration. This annex considers cup point set screw driven cartridge seal assemblies, not designs that utilize a key drive and split-ring location or shrink disk design sleeve drives.

This annex assumes that the set screws are evenly spaced in the drive collar and that the total axial load is evenly distributed to each set screw. If the drive collar were mounted such that the set screws offset the collar so it contacted the shaft on one side, then there will be added friction associated with contact between the drive collar and the shaft potentially increasing the axial load capability. As this is not the normal mounting practice, it is assumed that the radial distance between the shaft and drive collar is evenly distributed.

The axial holding capability is primarily a function of screw size, number of set screws and applied torque. However, many other factors such as presence of oil, process fluid temperature (thermal expansion), the finish and hardness of the shaft and set screws, the length of the threaded engagement and safety factors applied will impact the axial holding capability.

For example, load capability is reduced with lower hardness steel screws because of lower seating torque. Load capability of a drive collar will increase by adding additional set screws. To reduce the chance of slipping and to increase load capacity, a dimple can be drilled in the shaft into which the set screw's point enters. The downside of a dimpled shaft is the drive collar set screws may not align with the dimples after a maintenance event. Experience has shown that drive collars for seals that fall within the pressure and size limits of API 682 have conservative axial load capabilities.

The set screw need only be slightly harder than the shaft for to make a good impingement on the shaft and therefore deliver full holding power. However, if the set screw is softer than or only as hard as the shaft the holding power will be reduced.

To determine if the set screw is harder than the shaft, tighten the set-screw onto the shaft and then remove and examine the rim around the cup point. If the set-screw is harder, the rim itself will retain its sharp profile. If the set screw is softer than or only as hard as the shaft, the rim will be flattened indicating no impingement and, therefore, reduced holding power.

The ability of the drive collar to maintain the axial position of the assembled components is a significant safety issue. Since the axial holding capability of a drive collar is a function of many variables, it is difficult to provide a value for all conditions. As mentioned earlier, many factors will impact the axial holding capability of a drive collar and the values illustrated in Figure F.20 represent an average based on several methods of calculation.

The user should consult with the seal vendor to verify the drive collar axial load capability in high-pressure or large shaft diameter applications (applications exceeding the pressure rating or size of seals covered by this standard).

The nominal torsional holding power of a drive collar can be estimated by the product of the drive collar axial holding power and the shaft radius.

Typically cartridge drive collar set screws are tightened against the shaft. Table F.2 and Table F.3 give typical hardness values for shaft and set screw materials.

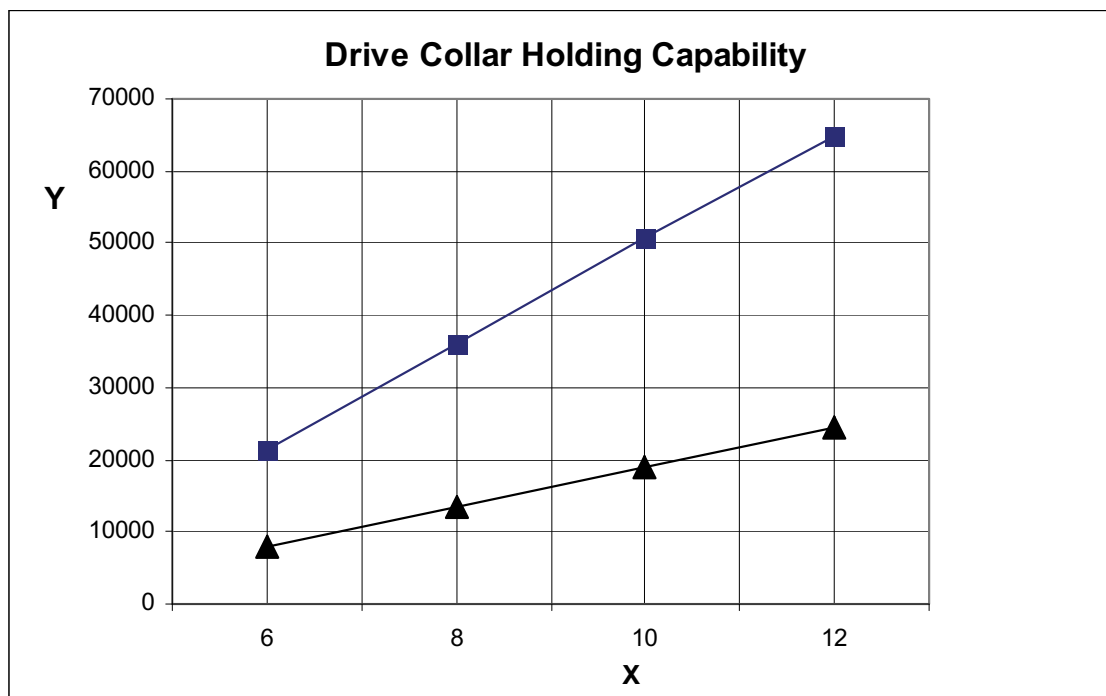

Key

X set screw diameter, mm

Y axial holding capability, N

1 drive collar with 8 set screws

2 drive collar with 3 set screws

Figure F.20—Drive Collar Holding Capability

Table F.2—Typical Hardness Ranges for Set Screw Materials

Material	Hardness (HRC)	
	min	max
316 SS	15	
C276	22	
410 SS (hardened)	41	43
416 SS	25	30
440C	58	
4140	37	45
4340	42	

Table F.3—Typical Hardness Ranges for Pump Shaft Materials

Material	Hardness (HRC)	
	min	max
Carbon steel	15	20
4140	30	38
316SS	15	20
12 % Chrome	20	32
4340 reduced hardness		22
17-4PH	22	35
Monel	18	

Table F.4 gives the estimated sleeve for various seal sizes based on 0.689 MPa (6.89 bar) (100 psi) seal chamber pressure. The product of axial load for a given shaft diameter and the ratio of the field or application seal chamber pressure to 0.689 MPa (6.89 bar) (100 psi) will provide the user with an estimate of the total axial load for a specific application.

Table F.4—Estimated Sleeve Axial Loads

Shaft Diameter		Axial Load	
Mm	(in.)	N	(lbf)
25	1.0	1048	236
38	1.5	1397	314
51	2.0	1747	393
64	2.5	2096	471
76	3.0	2446	550
89	3.5	2795	628
102	4.0	3144	707
114	4.5	3494	785

F.5 Rotating or Stationary Flexible Element Selection

F.5.1 General

Within the scope of API 682, configurations with either a rotating or stationary flexible element are considered to be technically equivalent. The optimum choice in using a rotating or stationary flexible element in a standardized cartridge assembly is not a simple decision and is influenced by many factors. This standard has default configurations, but it also recognizes, through included options, that the default selection may not always be the best choice. Some of factors that may influence the selection of a rotating or stationary flexible element are discussed below.

F.5.2 Perpendicularity

Perpendicularity of the mating ring to the shaft axis is important for both stationary and rotating flexible element designs.

The perpendicularity of a mating ring mounted in the gland plate (where a rotating flexible element is used) is controlled by the combination of the seal chamber face and support surface on the gland plate. The flexible element is required to flex with each rotation to accommodate any lack of perpendicularity, but for reliable seal performance there are limits to this function. A rotating flexible element seal is the standard default for Type A and Type B seals based on installed population.

Perpendicularity for a rotating mating ring mounted on the sleeve (where a stationary flexible element is used) is controlled by the seal sleeve run out and perpendicularity of support surface on the sleeve. It is independent of the seal chamber face run out. An advantage of a stationary flexible element is that it will deflect to a fixed position to align with the rotating face. A stationary flexible element seal is the standard default for Type C seals.

Both rotating and stationary flexible elements can provide reliable service when pump and seal construction complies with the perpendicularity, fits, clearances and runout limits in pump and seal standards such as API 682, API 610, and ASME B73.1. However, the use of a stationary flexible element is recommended when circumstances exist where these values can be exceeded. Some of the circumstances where a stationary flexible element may be the best choice are discussed below.

F.5.3 Stationary Flexible Element Selection

Stationary flexible elements may be the preferred choice and may provide more reliable seal operation when:

- a) seals are installed in high-temperature pumps where thermal distortion of the casing and/or gland plate will affect the alignment of the shaft to the seal chamber face. This is one reason stationary flexible elements are the default selection above 176 °C;
- b) seals are installed in ASME B73.1 and B73.2 pumps or multistage pumps with high levels of shaft flexure may affect the alignment of the shaft and seal chamber face;
- c) seals are installed in high-pressure pumps where the pressure results in excessive distortion of the seal chamber face and its alignment to the shaft axis;
- d) seals are installed in pumps with excessive pipe loads causing casing distortion affecting the alignment of the shaft and seal chamber face;
- e) the seal balance diameter exceeds 115 mm (4.5 in.);
- f) the peripheral face velocity exceeds 23 m/s (4500 ft/min).

F.5.4 Seal Flush

Use of a rotating flexible element may enable an improved flush location to the inner seal of a dual seal installation where long flexible elements (such as bellows, single spring and some multispring designs) are utilized. This is due to restricted seal chamber dimensions and the resulting adaptive hardware construction.

F.5.5 Shaft r/min and Peripheral Seal Velocity

As the rotating shaft speed increases, a rotating flexible element flexes at a correspondingly faster rate to keep the faces closed. At very high velocities (and for large seal sizes), the forces required to keep the faces closed become so large that they can negatively affect seal life. Stationary flexible elements are recommended if the face velocity exceeds 23 m/s or if the seal balance diameter exceeds 115 mm.

F.5.6 Suspended Solids

Several seal configurations have proved to be somewhat resistant to problems associated with sealing process fluids that contain suspended solids are listed below.

- Suspended solids in the seal chamber may be centrifuged away from important functional parts of a rotating flexible element when the process is on the outer surface.
- Seals using a stationary flexible element with springs external to the process liquid are also a proven design in process fluids with high particulate concentrations.
- Rotating metal bellows with the process liquid on the outer surface tend to throw out particulates from between the bellows in some services.

F.5.7 Bellows Vibration

Some bellows seals vibrate during operation and are sometimes equipped with dampening tabs or other devices to control vibration. The use of a stationary bellows seal can help to avoid this problem.

F.6 Throat and Throttle Bushings

F.6.1 General

Refer to Annex B for a discussion of throat and throttle bushing materials. The following subsections differentiate the application uses for these bushings.

F.6.2 Throat Bushings

Normally a throat bushing is provided by the pump vendor as part of the pump. Defined by API 610 and this standard, it is a device that forms a restrictive close clearance around the sleeve (or shaft) between the seal and the impeller. Throat bushing material supplied by the pump vendor as part of the pump back cover or seal chamber will comply with the applicable pump standards (such as Annex H of API 610). Typically this material can range from bronze to super duplex stainless steel and is selected based on compatibility with the process fluid and material of parts in close proximity.

A floating bushing as defined by this standard fits around the shaft or sleeve and has sufficient outer diameter clearance so it can move or “float” radially with movement or contact with the rotating part. A fixed or a floating throat bushing may be provided by the seal vendor and installed at the bottom of the seal chamber for several reasons. Examples include the following.

- a) *Improved isolation of the seal chamber*—A throat bushing will help decrease the communication of fluid between the pump casing and the seal chamber that can improve the product temperature margin. The application of a floating throat bushing may be used in conjunction with seal Piping Plan 23.
- b) *Decrease external flush fluid flow*—The close clearance created by the use of a floating throat bushing along with Piping Plan 32 can decrease the consumption of external flush fluid. The throat bushing is not intended to be used as a flow control device.
- c) *Increase seal chamber pressure*—The close clearance created by the use of a floating throat bushing can, at least temporarily, increase the seal chamber pressure when used with Piping Plans 11, 21, 31, and 41 improving the product temperature margin.

Lowering the flush fluid temperature and seal chamber fluid temperature is always preferable to pressurizing the seal chamber by using a floating throat bushing. Wear on a throat bushing installed primarily used to restrict flow and pressurize the seal chamber inevitably results in a decreased seal chamber pressure and possibly a lower product temperature margin. Since a fixed throat bushing is provided by the pump vendor, when a throat bushing is provided by the seal vendor it is often a floating design.

F.6.3 Throttle Bushings

A throttle bushing, defined by this standard, is a device mounted in the gland plate on the atmospheric side of the mechanical seal that forms a restrictively close clearance around the sleeve (or shaft). It is always mounted in the gland plate and is therefore supplied by the seal vendor. The standard throttle bushing material is carbon, but a spark resistant metallic material (i.e. bronze) and other nonmetallic materials have been used. Throttle bushings are fundamentally part of the seal leakage management system. Refer to F.1.1 and F.1.2 for more discussion of leakage management.

Category 1 seals are supplied with a fixed, solid carbon throttle bushings as standard and a floating carbon bushing is an option. Category 2 and Category 3 seals are supplied with a floating, solid carbon throttle bushing as standard. Floating carbon bushings can be a solid material or segmented design. A throttle bushing is supplied for all compliant Arrangement 1 seals; however they are rarely provided or needed when Arrangement 2 and Arrangement 3 seals are provided.

As shown in Figure F.1 and Figure F.2, leakage past a floating throttle bushing is greater than a containment seal, but is small enough to contain or redirect excessive seal leakage. It is suitable for restricting leakage to work effectively with quench (Piping Plan 62) or leakage detection systems (i.e. Piping Plan 65A, 65B, 66A, and 66B).

Annex G (normative)

Standard Piping Plans and Auxiliary Hardware

G.1 General

This annex contains drawings, descriptions, and tutorials of standard piping plans and auxiliary hardware that have regularly been used in industry. While not all of these plans are referenced in this standard, they may have applications in special cases with purchaser approval.

Seals shall be shipped with plastic shipping plugs installed in the ports. All plastic plugs shall be removed from the seal at installation. All ports shall be either connected to piping or tubing to support the appropriate piping plan or plugged with a metal plug as described in 6.1.2.18.

The pumps, seal chambers, and seal designs used in these figures are intended to illustrate the required principles and design features of the piping plans. Although all piping plans are illustrated with a generic single-stage, overhung horizontal centrifugal pump, the piping plans are equally applicable to other pump designs (e.g. vertical and between bearing pumps.) The seals used in the figures are also intended to show the generic location of the seals relative to the piping plans. Other seal designs detailed in this standard (e.g. types, configurations, categories, rotating vs stationary options) as well as designs from different manufacturers may have a different appearance than the generic seals used in the figures. The seals illustrated are not an endorsement of a specific design or configuration.

In piping plans using seal coolers, the figures show a generic cooler. The actual design of the cooler, port locations, and mounting requirements will be specified by the cooler supplier. Any piping plan using a seal cooler may interchangeably use either a water-cooled or air-cooled seal cooler (in accordance with the cooler requirements of this standard) and still retain the same piping plan designation.

The details for each of the piping plans represent the minimum requirements for the plans. It is not uncommon, however, for users of this standard to specify slight variations to these plans. An example may be that the user specifies a level switch rather than a level transmitter. Substitutions for the instrumentation requirements in these plans are allowed (with purchaser's approval) while still retaining the piping plan designations described in this standard. To accommodate piping plans not shown in this annex, a Piping Plan 99 should be selected that allows the purchaser to fully specify the requirements of the piping plan.

Unless otherwise specified, the scope of supply for the piping plans in this annex will be mutually agreed upon between the purchaser and the vendor.

G.2 Symbol Library









flow orifice	
level indicator	
level transmitter with local indicator	
differential pressure transmitter with local indicator	
pressure indicator	
pressure transmitter with local indicator	
temperature indicator	
temperature transmitter with local indicator	
high-level alarm set point	HLA
low level alarm set point	LLA
normal liquid level	NLL

Figure G.1—Instrument Symbols











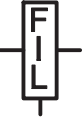

bladder accumulator	
cyclone separator	
filter, coalescing	
flow orifice	
seal cooler	
strainer, Y	
valve, normally open	
valve, normally closed	
valve, check	
valve, needle	
valve, pressure control	
valve, pressure relief	

Figure G.2—Equipment Symbols

G.3 Piping Plan 01

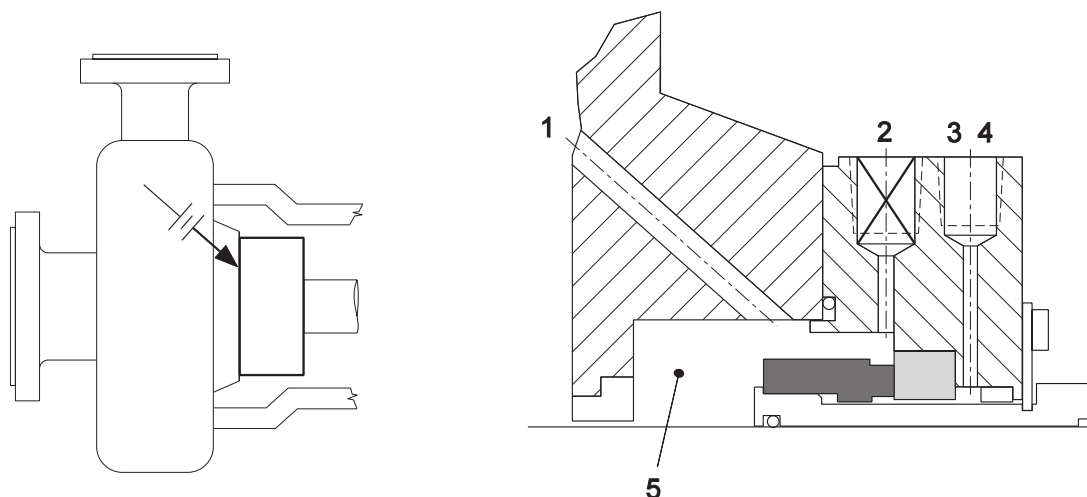

a) Piping and Instrumentation Schematic

b) Seal Chamber Details

Key

- 1 inlet
- 2 flush (F), plugged (for possible future circulating fluid or for venting on vertical pumps)
- 3 quench (Q)
- 4 drain (D)
- 5 seal chamber

Figure G.3—Standard Seal Piping Plan 01

In Piping Plan 01, integral (internal) recirculation is from a high-pressure region of the pump to the seal chamber.

NOTE Piping Plan 01 is similar to a Piping Plan 11 except that internal porting is used to direct flow to the seal chamber from an area behind the impeller near the discharge. This porting also serves to vent the chamber during commissioning of the pump. This plan is recommended for clean fluids only. Piping Plan 01 may be useful with liquids that thicken or solidify at normal ambient temperatures to minimize the risk of freezing the fluid in flush piping. Special attention is needed to ensure that the recirculation supplied is sufficient for the seal operating requirements.

Piping Plan 01 is not recommended for vertical pumps because of difficulty in venting the seal chamber.

G.4 Piping Plan 02

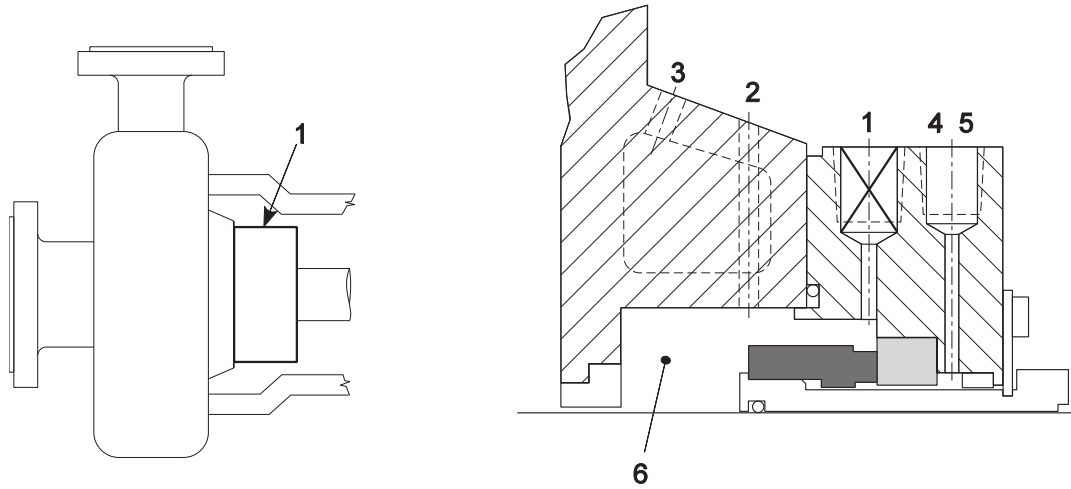

a) Piping and Instrumentation Schematic

b) Seal Chamber Details

Key

- 1 flush (F), plugged (for possible future circulating fluid or for venting on vertical pumps)
- 2 vent (V), if required
- 3 heating/cooling inlet (HI or CI), heating /cooling outlet (HO or CO), if required
- 4 quench (Q)
- 5 drain (D)
- 6 seal chamber

Figure G.4—Standard Seal Piping Plan 02

Piping Plan 02 has a dead-ended seal chamber with no recirculation of flushed fluid.

Piping Plan 02 is more common in the chemical industry in applications with low seal chamber pressures and process temperatures. The process fluid should be relatively clean to avoid excessive erosion of the seal gland, seal chamber, or seal parts created by the swirling flow pattern. The vapor pressure sensitivity of the process fluid should also be taken into consideration to avoid flashing conditions in the seal chamber or at the seal faces. Piping Plan 02 can be used with cool clean fluids with high specific heats, such as water, in relatively low-speed pumps. The product temperature margin should be carefully reviewed for any application where the selection of Piping Plan 02 is being considered.

Pumps may optionally be provided with cooling or heating jackets to assist in controlling the temperature in the seal chamber. Cooling jackets are prone to fouling in high-temperature applications and shall be used only with great care.

G.5 Piping Plan 03

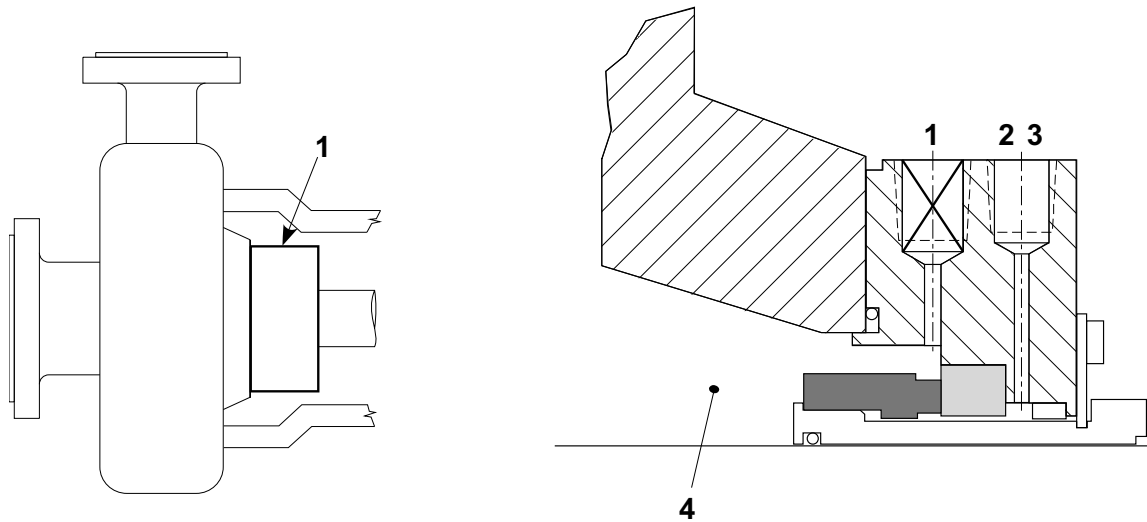

a) Piping and Instrumentation Schematic

b) Seal Chamber Details

Key

- 1 flush (F), plugged (for possible future circulating fluid or for venting on vertical pumps)
- 2 quench (Q)
- 3 drain (D)
- 4 seal chamber

Figure G.5—Standard Seal Piping Plan 03

In Piping Plan 03 there is circulation between the seal chamber and the pump created by the design of the seal chamber.

Piping Plan 03 is commonly used in pump designs where the seal chamber has a tapered bore and no throat bushing. This seal chamber geometry or flow enhancement features in the seal chamber create circulation that provides cooling for the seal and vent air or vapors from the seal chamber. This plan is most often used in applications where there is not significant seal generated heat. It is also used in applications where there may be solids that could collect in a traditional seal chamber.

NOTE This piping plan is most commonly used with Category 1 seals.

G.6 Piping Plan 11

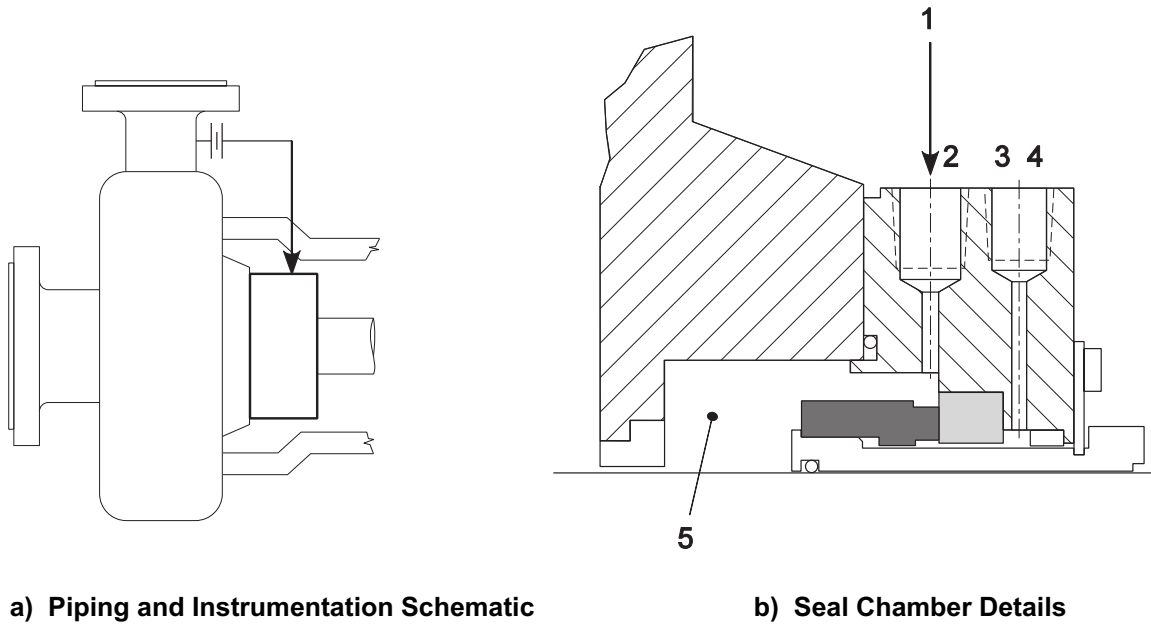

Key

- | | |
|---|---|
| 1 | from high-pressure region of pump (pump discharge or pump discharge piping) |
| 2 | flush (F) |
| 3 | quench (Q) |
| 4 | drain (D) |
| 5 | seal chamber |

Figure G.6—Standard Seal Piping Plan 11

In Piping Plan 11 there is recirculation from a high-pressure region of the pump (typically the pump discharge or the pump discharge piping) through a flow control orifice to the seal. With purchaser approval, the flow control orifice may be omitted if it is not needed to achieve the required flush flow rate.

Piping Plan 11 is the default seal flush plan for all Arrangement 1 and 2 seals. In Piping Plan 11, product is routed from the pump discharge to the seal chamber to provide cooling for the seal and to vent air or vapors from the seal chamber. Fluid then flows from the seal chamber back into the process stream. It is the most commonly used flush plan for clean general service equipment. For high-head applications, careful consideration should be given to calculation of the required flush flow rate. Calculations are required to determine the proper orifice and throat bushing dimensions to assure adequate seal flush flow. In pumps with low differential head or pumping high-viscosity fluids, the required flow rate for the piping plan may be achieved without the flow control orifice. Care shall be taken when using this plan with polymerizing fluid that may plug the orifice and connecting piping.

G.7 Piping Plan 12

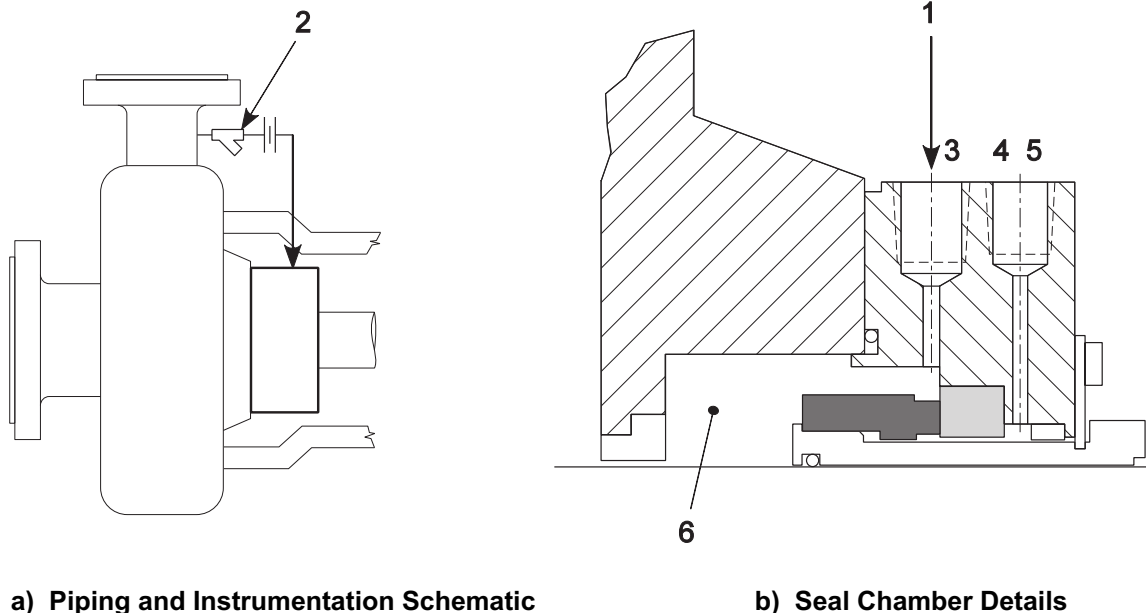

a) Piping and Instrumentation Schematic

b) Seal Chamber Details

Key

- 1 from high-pressure region of pump (pump discharge or pump discharge piping)
- 2 strainer
- 3 flush (F)
- 4 quench (Q)
- 5 drain (D)
- 6 seal chamber

Figure G.7—Standard Seal Piping Plan 12

In Piping Plan 12 there is recirculation from a high-pressure region of the pump (typically the pump discharge or the pump discharge piping) through a strainer and a flow control orifice into the seal. With purchaser approval, the flow control orifice may be omitted if it is not needed to achieve the required flush flow rate.

This plan is similar to a Piping Plan 11, with the addition of a strainer to remove occasional particles. Strainers are not commonly recommended in piping plans because blockage of the strainer will cause a seal failure.

This plan has not proven to achieve a three year (3-yr) operating life.

G.8 Piping Plan 13

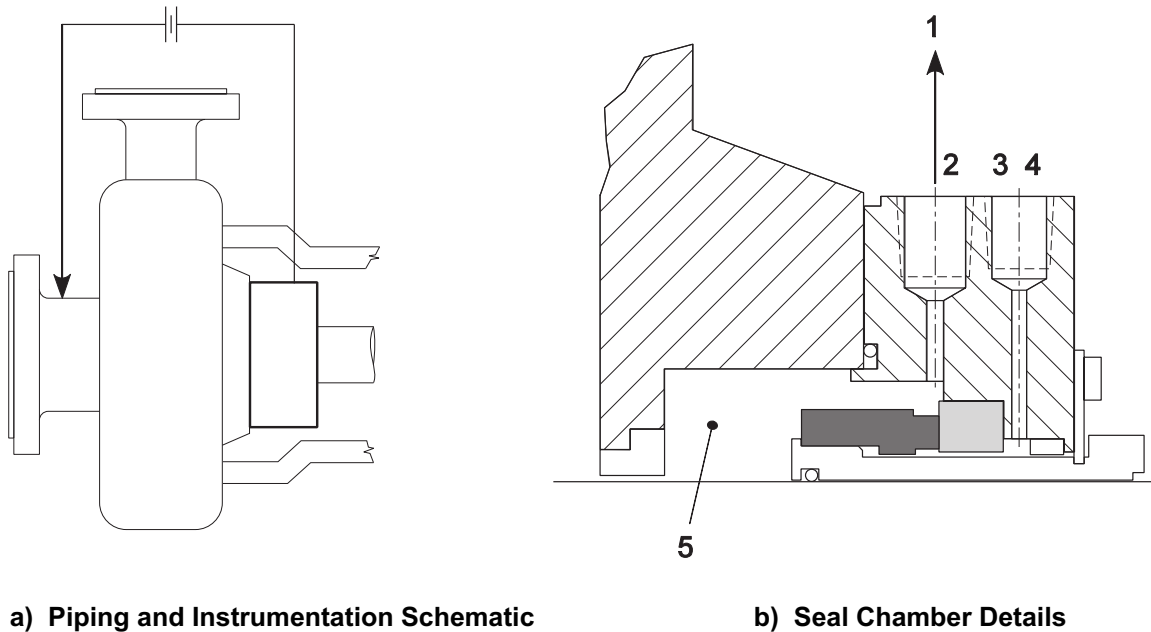

Key

- 1 to pump suction
- 2 flush (F)
- 3 quench (Q)
- 4 drain (D)
- 5 seal chamber

Figure G.8—Standard Seal Piping Plan 13

In Piping Plan 13 there is recirculation from the seal chamber through a flow control orifice and back to the pump suction or pump suction piping. With purchaser approval, the flow control orifice may be omitted if it is not needed to achieve the required flush flow rate.

NOTE Piping Plan 13 is the standard flush plan selection for vertical pumps that are not provided with a bleed bushing below the seal chamber. The seal chamber pressure on vertical pumps supplied without a bleed bushing would normally operate at full discharge pressure. Because of this arrangement there is no pressure differential to allow a Piping Plan 11 to work. In Piping Plan 13, product is routed from the seal chamber back to the pump suction to provide cooling for the seal and to vent air or vapors from the seal chamber.

Piping Plan 13 provides self-venting on vertical in-line pumps provided differential pressure is sufficient to ensure circulation and seal chamber pressure is sufficient to prevent vaporization.

Piping Plan 13 is also used in high-head pumps where the use of Piping Plan 11 would require too small of an orifice or would produce too high a flush flow rate. This plan will generally not work well in low-head pumps because of the low pressure differential between the seal chamber and the pump suction. The suitability of the service for Piping Plan 13 can be determined by calculating the required flush flow rate and then calculating the required orifice size.

A distributed flush injection is not recommended with a Piping Plan 13.

G.9 Piping Plan 14

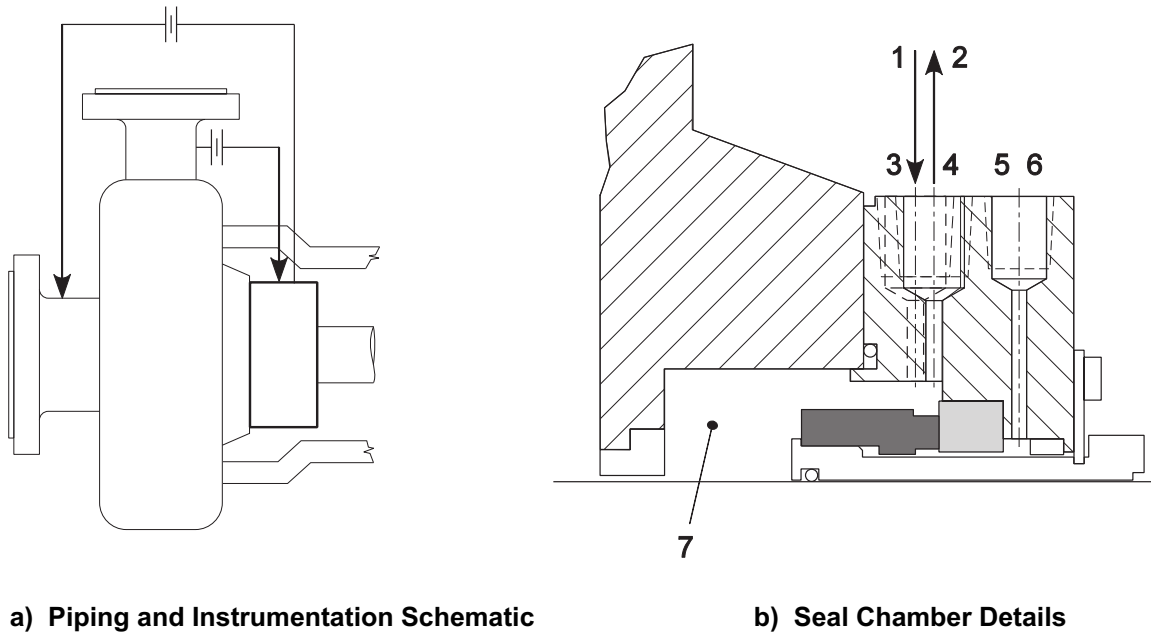

Key

- 1 from pump discharge
- 2 to pump suction
- 3 flush inlet (FI)
- 4 flush outlet (FO)
- 5 quench (Q)
- 6 drain (D)
- 7 seal chamber

Figure G.9—Standard Seal Piping Plan 14

In Piping Plan 14 there is recirculation from pump discharge through a flow control orifice to the seal and simultaneously from the seal chamber through a flow control orifice (if required) to pump suction. This allows fluid to enter the seal chamber and provide cooling while continuously venting the pressure in the seal chamber. Piping Plan 14 is a combination of Piping Plan 11 and Piping Plan 13.

NOTE Piping Plan 14 is most commonly used on vertical pumps.

A distributed flush injection is not recommended with a Piping Plan 14.

G.10 Plan 21

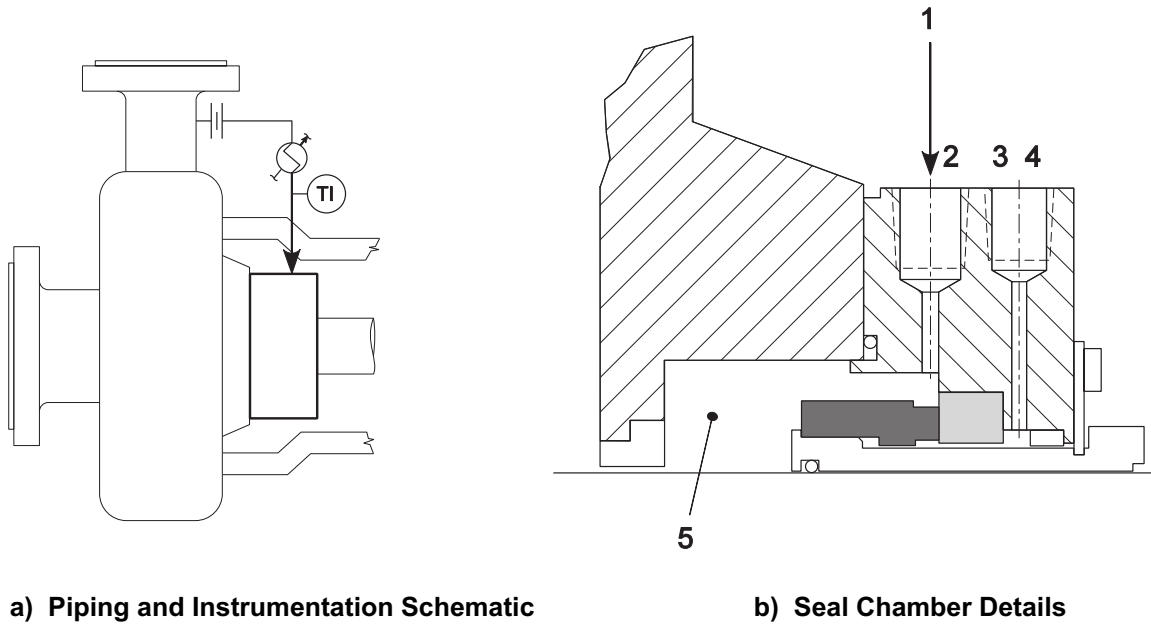

Key

- 1 from high-pressure region of pump (pump discharge or pump discharge piping)
- 2 flush (F)
- 3 quench (Q)
- 4 drain (D)
- 5 seal chamber
- TI temperature indicator

Figure G.10—Standard Seal Piping Plan 21

In Piping Plan 21 there is recirculation from a high-pressure region of the pump (typically the pump discharge or the pump discharge piping) through a flow control orifice and cooler, then into the seal chamber. With purchaser approval, the flow control orifice may be omitted if it is not needed to achieve the required flush flow rate.

In Piping Plan 21, product in the seal chamber is isolated from that in the impeller area of the pump by a throat bushing. Piping Plan 21 provides a cool flush to the seal. This may be needed to improve the margin to vapor formation, to meet secondary sealing element temperature limits, to reduce coking or polymerizing, or to improve lubricity (as in hot water). The benefit of Piping Plan 21 is that it not only provides a cool flush but also has sufficient pressure differential to allow good flow rates. The drawback is that the cooler duty is high, leading to fouling and plugging on the water side and potential plugging on the process side if the fluid becomes too viscous. Piping Plan 21 works best in dry climates where a vertically oriented, finned air cooler is used instead of a water cooler. Piping Plan 21 also uses more energy than Piping Plan 23, because the pumped fluid that is used for the flush is repumped from suction back to the discharge. A close clearance throat bushing is recommended to isolate the cooled process fluid from the pump fluid.

In pumps with low differential head or pumping high-viscosity fluids, the required flow rate for the piping plan may be achieved without the flow control orifice. Care shall be taken when using this plan with polymerizing fluid that may plug the orifice and connecting piping.

G.11 Plan 22

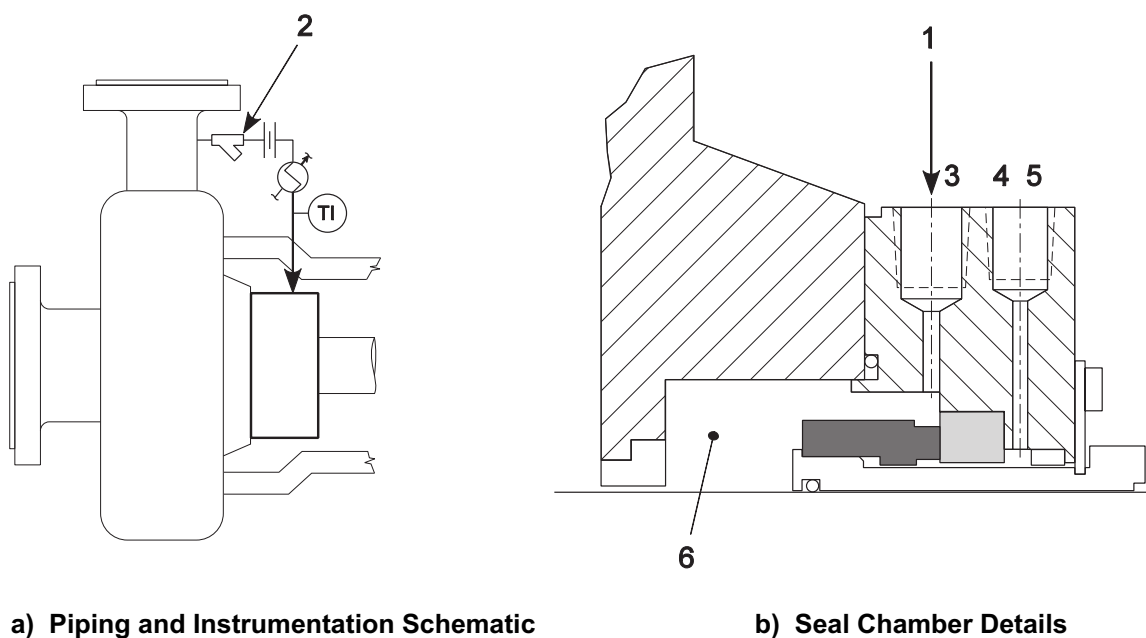

Key

- 1 from high-pressure region of pump (pump discharge or pump discharge piping)
- 2 strainer
- 3 flush (F)
- 4 quench (Q)
- 5 drain (D)
- 6 seal chamber
- TI temperature indicator

Figure G.11—Standard Seal Piping Plan 22

In Piping Plan 22 there is recirculation from a high-pressure region of the pump (typically the pump discharge or the pump discharge piping) through a strainer, a flow control orifice, a cooler, and into the seal chamber.

This plan is similar to a Piping Plan 21, with the addition of a strainer to remove occasional particles. Strainers are not commonly recommended in piping plans because blockage of the strainer will cause a seal failure.

This plan has not proven to achieve a three-year (3-yr) operating life.

G.12 Piping Plan 23

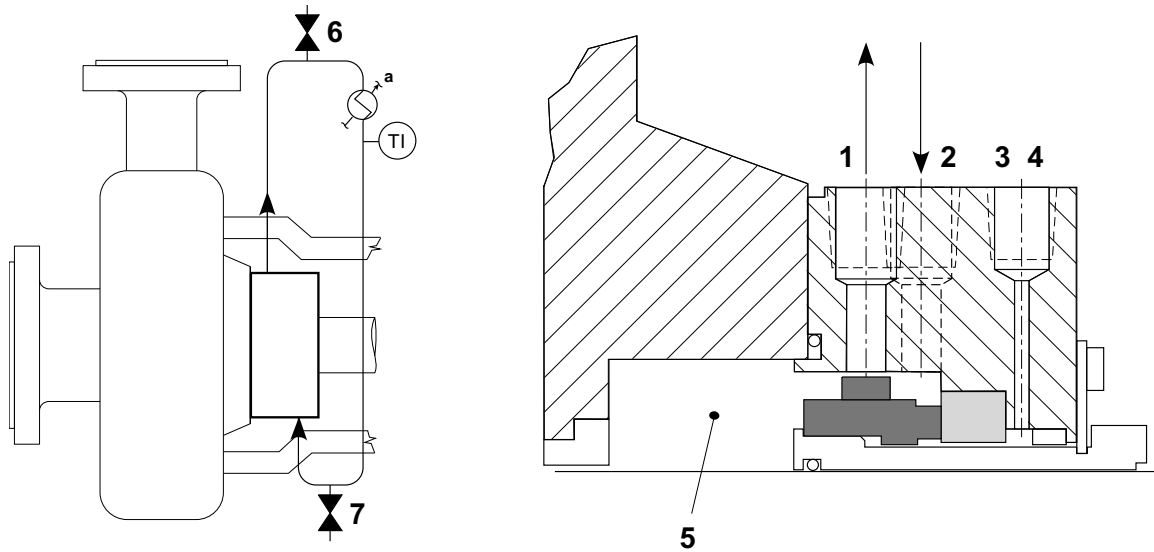

a) Piping and Instrumentation Schematic

b) Seal Chamber Details

Key

- 1 flush outlet (FO)
- 2 flush inlet (FI)
- 3 quench (Q)
- 4 drain (D)
- 5 seal chamber
- 6 vent (normally closed)
- 7 drain (normally closed)
- TI temperature indicator

^a Vertically oriented finned air cooler shall be installed if specified.

Figure G.12—Standard Seal Piping Plan 23

In Piping Plan 23 there is recirculation from a circulation device in the seal chamber through a cooler and back into the into the seal chamber.

NOTE In Piping Plan 23, product in the seal chamber is isolated from that in the impeller area of the pump by a throat bushing. The seal is equipped with an internal circulating device that circulates seal chamber fluid through a cooler and back to the seal chamber. To maximize circulation, the piping losses should be minimized through the proper selection of pipe size, elimination of fittings, use of large radius bends, and reduction in the length of piping runs. See Figure G.37 for recommended piping practices.

In Piping Plan 23, the cooler cools only that fluid in which the seal operates, and this cool fluid does not enter the process. This results in high energy efficiency. Lessening the duty is very desirable because it extends the life of the cooler. The industry has considerable negative experience with Piping Plan 21 and Piping Plan 22 because of cooler plugging.

Piping Plan 23 is the plan of choice for all hot water services, particularly boiler feed water, and many hydrocarbon services. This plan is the standard selection for hot water at 80 °C (180 °F) and above, and boiler feed water. Hot water has very low lubricity above 80 °C (180 °F), resulting in high seal face wear.

This plan is also desirable in many hydrocarbon and chemical services where it is necessary to cool the fluid to establish the required margin between fluid vapor pressure (at the seal chamber temperature) and seal chamber pressure. In a Piping Plan 23, the cooler only removes seal face-generated heat plus heat soak from the process. This duty is usually much less severe than that in Piping Plan 21 or Piping Plan 22.

Effective flow of the Piping Plan 23 system is only achieved with proper exclusion of all gas and air bubbles from the seal cooler and piping. Venting of the system during commissioning is critical to proper operation (as referenced in 6.1.2.20).

High-freezing-point and viscous products should be considered when selecting a Piping Plan 23 flush system. The cooler might cool the fluid below the point of circulation. In these applications, consider using steam as a cooling medium, or utilize a Piping Plan 21 system. Vent line should be connected to drain or recovery system to prevent exposing the operator to process during venting

A distributed flush injection is not recommended with a Piping Plan 23.

G.13 Piping Plan 31

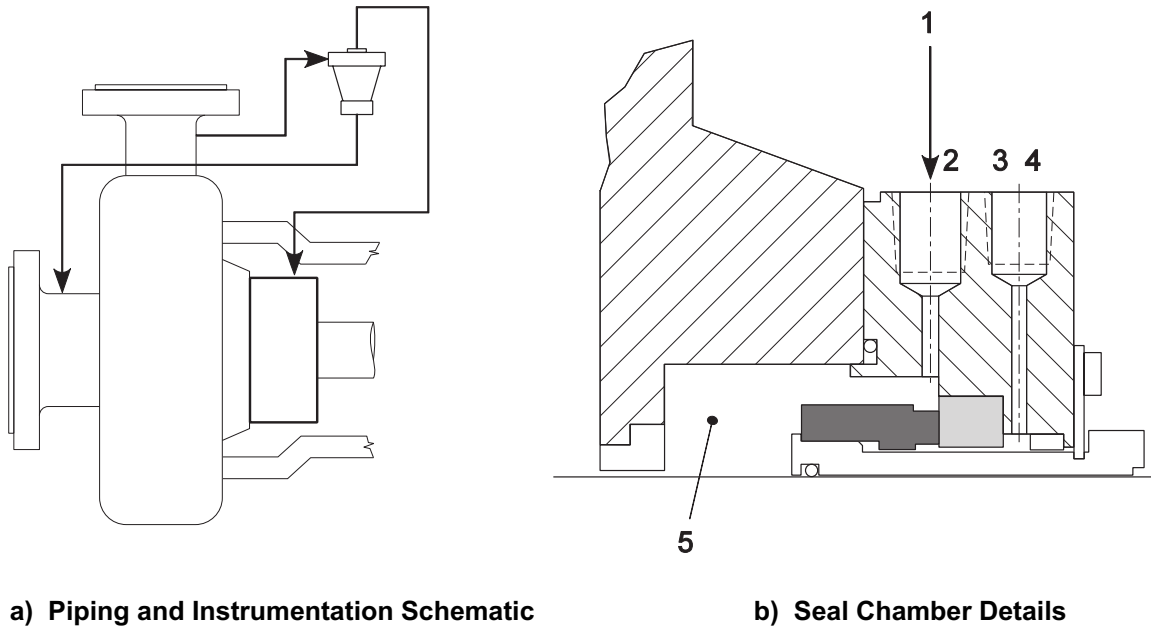

Key

- | | |
|---|--|
| 1 | from clean discharge connection of cyclone separator |
| 2 | flush (F) |
| 3 | quench (Q) |
| 4 | drain (D) |
| 5 | seal chamber |

Figure G.13—Standard Seal Piping Plan 31

In Piping Plan 31 there is recirculation from a high-pressure region of the pump (typically the pump discharge or the pump discharge piping) through a cyclone separator delivering the clean fluid to the seal chamber. The solids are delivered to the pump suction line.

Piping Plan 31 is specified only for services containing solids with a specific gravity at least twice that of the process fluid. A typical use of this plan is water service to remove sand or pipe slag. In Piping Plan 31, product is routed from the discharge of the pump into a cyclone separator. Solid particles are centrifuged from the stream and routed back to suction. The seal flush is routed from the cyclone separator into the flush connection on the seal gland plate. If the process stream is very dirty or is a slurry, Piping Plan 31 typically is inadequate and is not recommended. The use of a pump throat bushing is recommended when a Piping Plan 31 is specified.

Cyclone separators are not generally recommended for process fluids that contain gases.

Field experience has shown that abrasive wear on the inside of the cyclone may result in reduced reliability. This plan has not proven to consistently achieve a three-year (3-yr) operating life.

G.14 Piping Plan 32

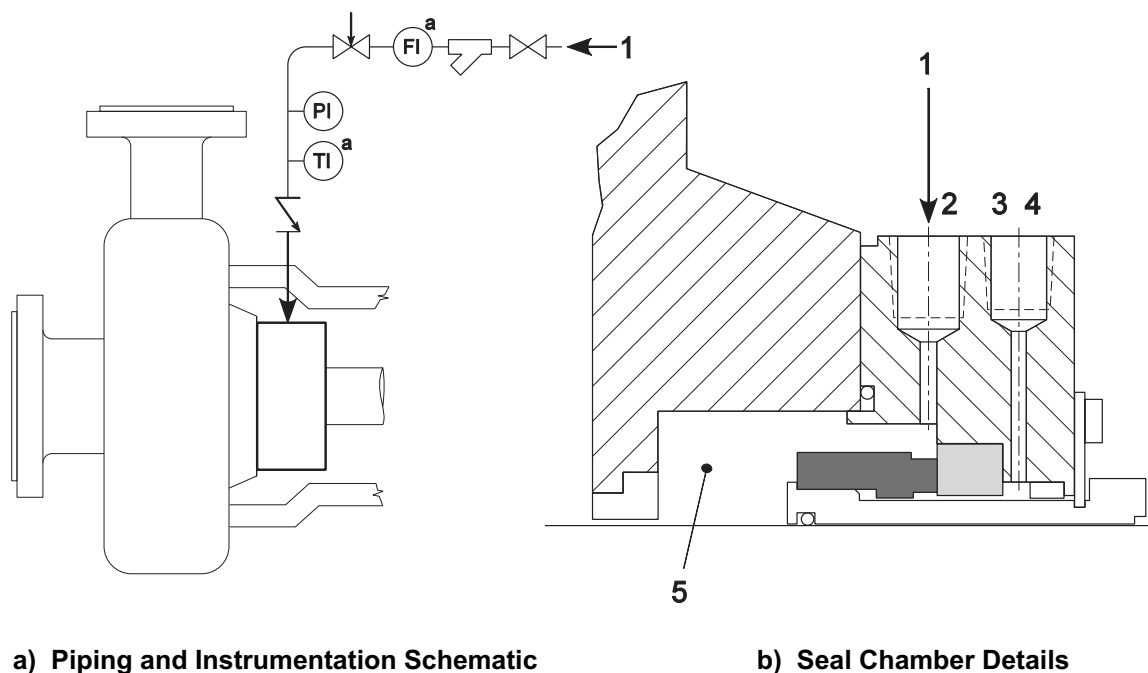

a) Piping and Instrumentation Schematic

b) Seal Chamber Details

Key

1	from external source	5	seal chamber
2	flush (F)	FI	flow indicator
3	quench (Q)	PI	pressure indicator
4	drain (D)	TI	temperature indicator
a	Optional		

Figure G.14—Standard Seal Piping Plan 32

In Piping Plan 32, flush is injected into the seal chamber from an external source.

NOTE Piping Plan 32 is used in services containing solids or contaminants, in which a suitable cleaner or cooler external flush will improve the seal environment. It is also used to reduce flashing or air intrusion (in vacuum services) across the seal faces by providing a flush that has a lower vapor pressure or that will raise the seal chamber pressure to an acceptable level.

In Piping Plan 32, the flushing product is brought from an external source to the seal. The external flush should be continuous and reliable even during nonstandard situations such as start-up or shutdown.

Care shall be exercised in choosing a Piping Plan 32 flush fluid. Since the fluid will flow into the process, it shall be chemically compatible with the process and not degrade the quality of the process fluid. In high-temperature applications, the user should consider the effects of the potential for the Piping Plan 32 flush fluid to flash under pump conditions and degrade pump performance.

This plan is almost always used in conjunction with a close-clearance throat bushing. The bushing can function as a throttling device to maintain an elevated pressure in the stuffing box or as a barrier to isolate the pumped product from the seal chamber.

Piping Plan 32 is not recommended for cooling only, as the energy costs can be very high. Product degradation costs should also be considered when using a Piping Plan 32.

G.15 Piping Plan 41

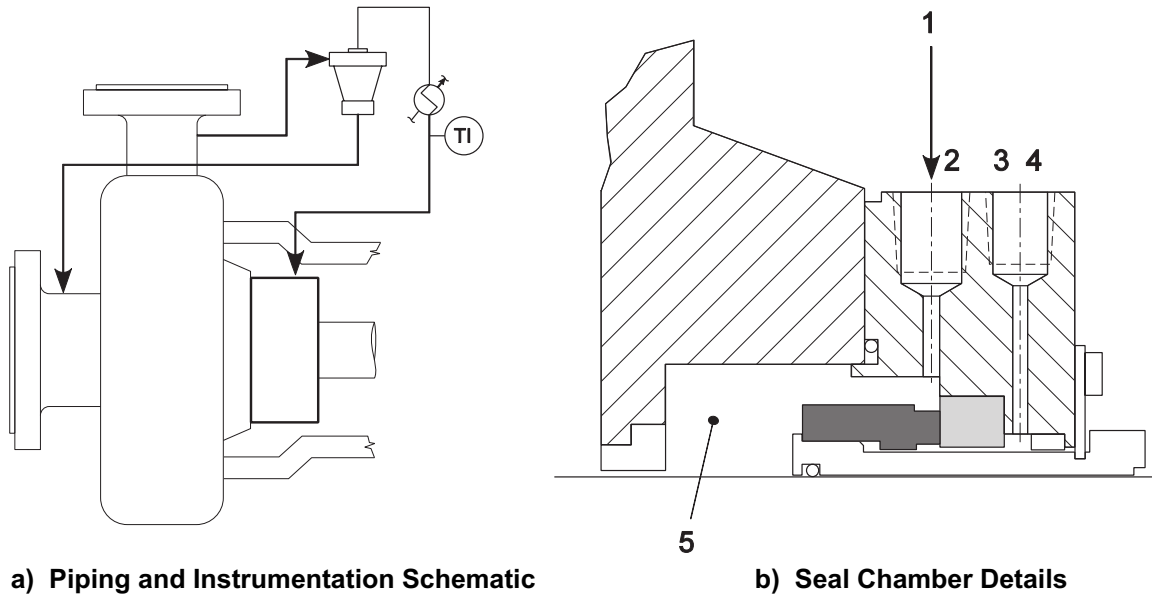

Key

1	from cooler
2	flush (F)
3	quench (Q)
4	drain (D)
5	seal chamber
TI	temperature indicator

Figure G.15—Standard Seal Piping Plan 41

In Piping Plan 41 there is recirculation from a high-pressure region of the pump (typically the pump discharge or the pump discharge piping) through a cyclone separator delivering the clean fluid to a cooler and then to the seal chamber. The solids are delivered to the pump suction line.

Piping Plan 41 is a combination of Piping Plan 21 and Piping Plan 31 and is specified only for hot services containing solids. Contained solids should have a specific gravity of at least twice that of the process fluid. For this seal plan to be used, the seal should require a cool flush. This cool flush may be needed to improve the temperature margin over the fluid vapor pressure, or to meet secondary sealing element temperature limits, or to reduce coking or polymerizing, or to improve lubricity (as in hot water). A typical use of this plan is in a hot water service to remove sand or pipe slag.

In Piping Plan 41, product is routed from the discharge of the pump into a cyclone separator. Solid particles are centrifuged from the stream and routed back to suction. The seal flush is then routed from the cyclone separator through a cooler and into the flush connection on the seal plate.

If the process stream is very dirty or is a slurry, Piping Plan 41 typically is inadequate and is not recommended. The benefits, detriments, and the best conditions for the use of the cooler in the flush stream can be found in the write-up on Piping Plan 21. The use of a pump throat bushing is recommended when a Piping Plan 41 is specified.

Field experience has shown that abrasive wear on the inside of the cyclone may result in reduced reliability. This plan has not proven to consistently achieve a three-year (3-yr) operating life.

G.16 Piping Plan 51

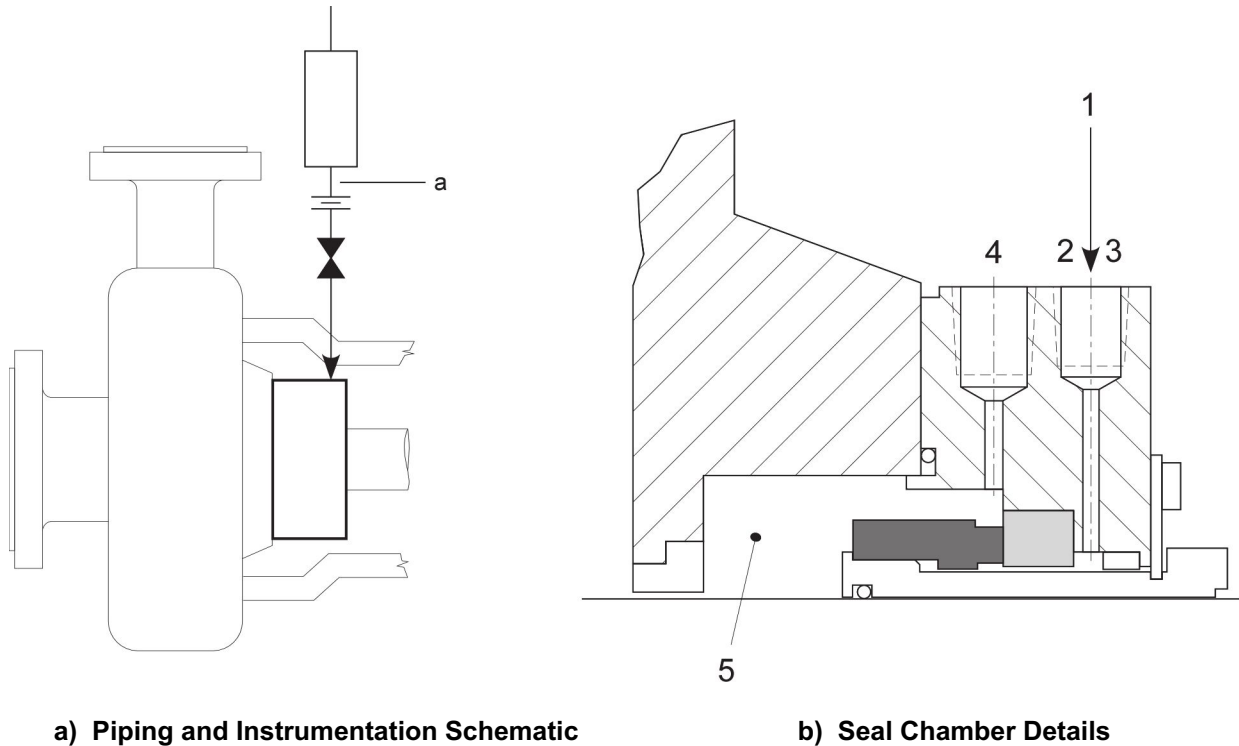

Key

- 1 from reservoir
- 2 quench (Q)
- 3 drain (D), plugged
- 4 flush (F)
- 5 seal chamber

^a Items below this line shall be provided by the vendor. Items above this line are the responsibility of the purchaser

Figure G.16—Standard Seal Piping Plan 51

In Piping Plan 51 there is an external reservoir providing a dead-ended blanket for fluid to the quench connection of the gland plate on an Arrangement 1 seal. A Piping Plan 51 is typically used when a dead-ended atmospheric quench is needed. One example where this might be used is to provide a means to prevent or remove any ice formation on the atmospheric side of the seal of a pump operating with a fluid below 0 °C (32 °F).

One method of operation is to fill the quench reservoir with a suitable liquid. While preparing the pump for startup the block valve below the reservoir is opened and the quench liquid is allowed to sit in the area between the seal and throttle bushing. Just prior to pump startup the block valve is closed to ensure the pot is only exposed to atmospheric pressure. This piping plan is only recommended for vertical applications.

G.17 Piping Plan 52

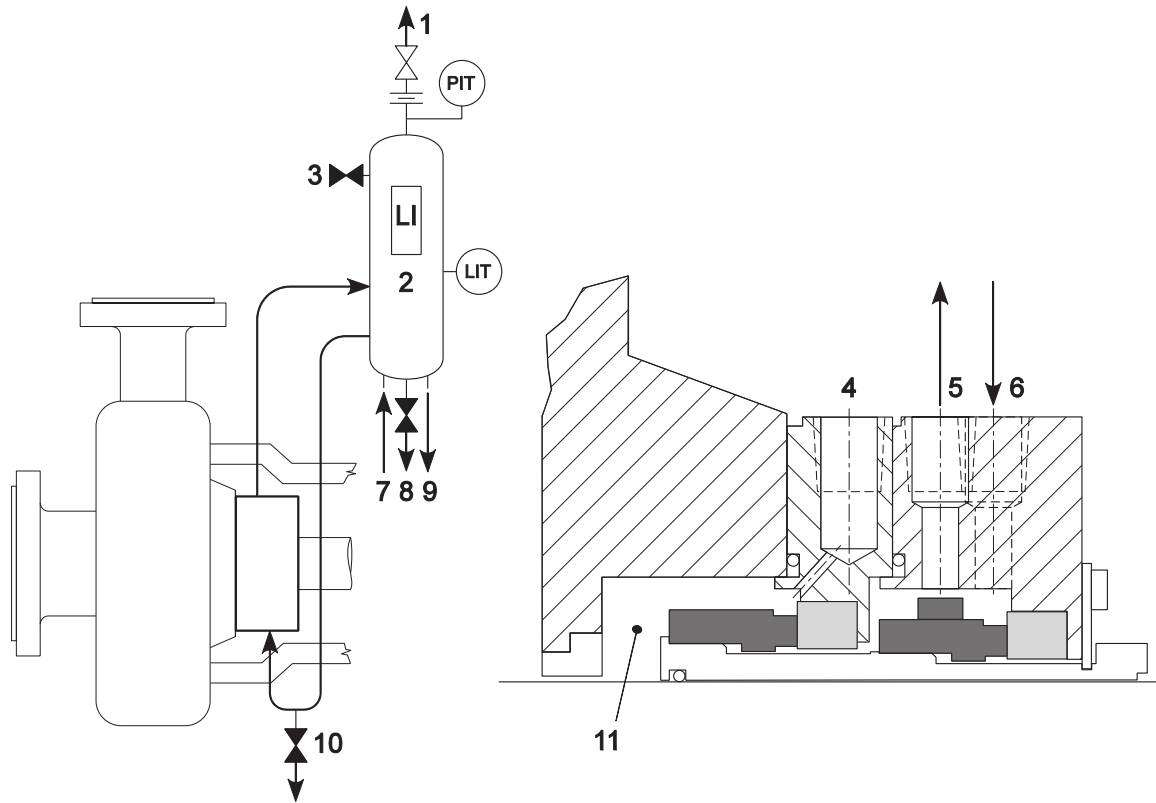

a) Piping and Instrumentation Schematic

b) Seal Chamber Details

Key

1	to collection system	9	cooling water out
2	reservoir	10	buffer fluid drain
3	make-up buffer liquid	11	seal chamber
4	flush (F)	LI	level indicator
5	liquid buffer out (LBO)	LIT	level transmitter with local indicator
6	liquid buffer in (LBI)	PIT	pressure transmitter with local indicator
7	cooling water in		
8	reservoir buffer fluid drain		

Figure G.17—Standard Seal Piping Plan 52

In Piping Plan 52 there is an external reservoir providing buffer liquid for the outer seal of an Arrangement 2 seal. The buffer liquid shall be maintained at a pressure less than seal chamber pressure and less than 0.28 MPa (2.8 bar) (40 psi).

Buffer liquid is circulated to and from the reservoir by means of an internal circulating device. To maximize buffer liquid circulation, the piping losses should be minimized through the proper selection of pipe size, elimination of fittings, use of large radius bends, and reduction in the length of piping runs.

Piping Plan 52 is used with Arrangement 2 seals, with a contacting wet containment seal (configuration 2CW-CW) utilizing a liquid buffer system. It is normally used in services where process fluid leakage to

atmosphere should be minimized and contained. It is also used in applications where the process may solidify in contact with atmosphere or in applications where additional heat removal from the inner seal is required. The buffer liquid is contained in a seal reservoir that is vented to a collection system, thus maintaining the buffer system pressure close to atmospheric.

Piping Plan 52 works best with clean, nonpolymerizing, pure products that have a vapor pressure higher than the buffer system pressure. Leakage of higher vapor pressure process liquids into the buffer system will flash in the seal reservoir and the vapor can escape to the collection system.

Inner seal process liquid leakage will normally mix with the buffer fluid and contaminate the buffer liquid over time. Maintenance associated with seal repairs, filling, draining, and flushing a contaminated buffer system can be considerable.

For general recommendations on piping practices and reservoir details, see Figure G.35, Figure G.36, and Figure G.38.

G.18 Piping Plan 53A

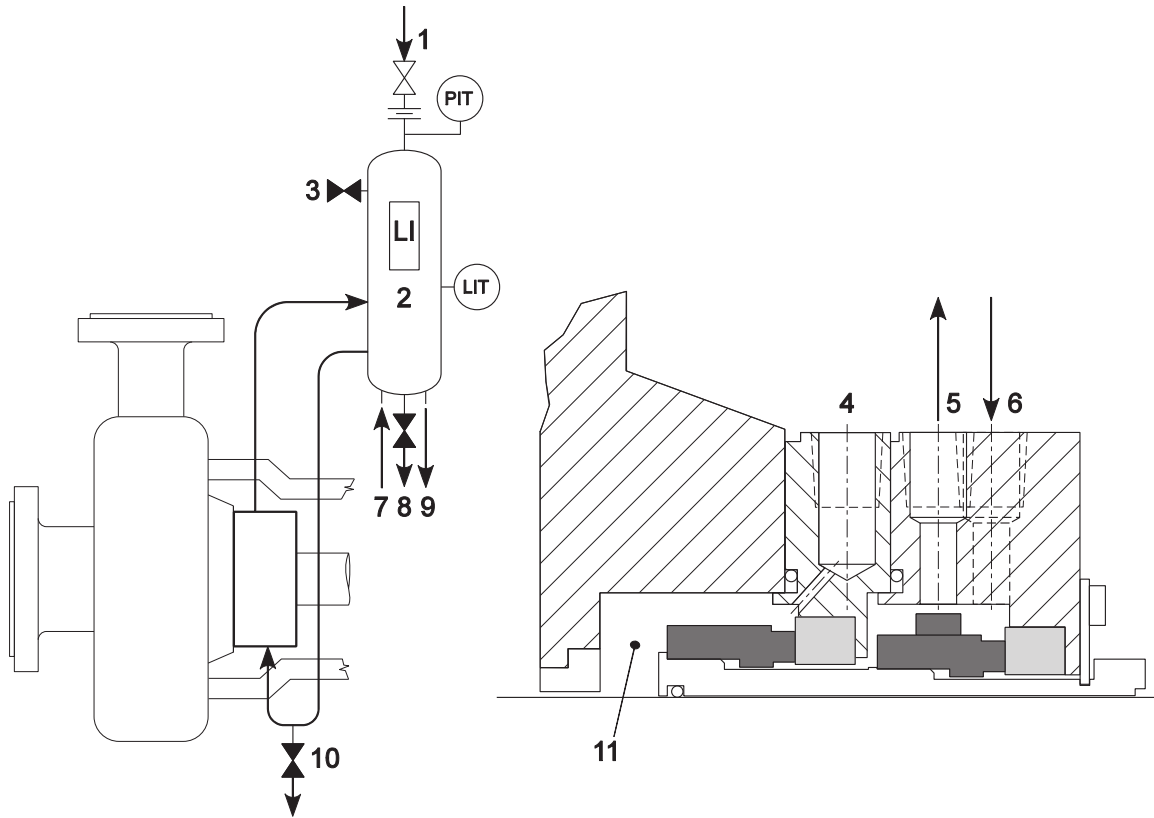

a) Piping and Instrumentation Schematic

b) Seal Chamber Details

Key

1	from external pressure source	9	cooling water out
2	reservoir	10	barrier fluid drain
3	make-up barrier liquid	11	seal chamber
4	flush (F)	LI	level indicator
5	liquid barrier out (LBO)	LIT	level transmitter with local indicator
6	liquid barrier in (LBI)	PIT	pressure transmitter with local indicator
7	cooling water in		
8	reservoir barrier fluid drain		

Figure G.18—Standard Seal Piping Plan 53A

In Piping Plan 53A there is a pressurized external barrier fluid reservoir supplying clean fluid to the barrier fluid seal chamber. The barrier liquid is maintained at a pressure greater than seal chamber pressure.

Barrier liquid is circulated to and from the reservoir by means of an internal circulating device. To maximize barrier liquid circulation, the piping losses should be minimized through the proper selection of pipe size, elimination of fittings, use of large radius bends, and reduction in the length of piping runs.

Piping Plan 53A is used with an Arrangement 3 seal and used in services where no leakage to atmosphere can be tolerated. It may also be selected for applications where the pump may be operated dry or the pump process fluid may be damaging to the seal faces.

A Piping Plan 53A system consists of dual mechanical seals with a barrier liquid between them. The barrier liquid is contained in a reservoir that is pressurized above the seal chamber pressure. Inner seal leakage will be barrier liquid leakage into the product. There will always be some leakage. If seal chamber gauge pressures vary significantly, the inner and outer seal stresses can be reduced by the application of a controlled differential pressure regulator. For specific recommendations on barrier liquid pressurization, see Annex F.

A 3 mm (0.125 in.) orifice is provided in the pressurization gas supply line to limit gas flow into the process in the event of an inner seal failure.

The following comments compare the differences and considerations between all dual pressurized piping plans (Piping Plan 53A, 53B and 53C) and dual unpressurized piping plans (Piping Plan 52). Piping Plan 53 is usually chosen over Piping Plan 52 for dirty, abrasive, or polymerizing products that would either damage the seal faces or cause problems with the buffer liquid system if Piping Plan 52 were used. There are two operational features of a Piping Plan 53 that are noteworthy, as follows.

- a) The clean barrier liquid provides lubrication to the seal faces, but the barrier liquid that passes across the inner seal faces will enter the pumped process stream. Therefore, the process liquid shall be compatible with the barrier liquid and be able to tolerate a small amount of contamination from the barrier liquid.
- b) The reservoir pressure should always exceed the maximum seal chamber pressure by a minimum of 0.14 MPa (1.4 bar) (20 psi) (as referenced in 8.3.6.1.10). If the reservoir pressure is less than the seal chamber pressure than the normal leakage flow direction across the inner seal will be reversed and the seal system will begin to operate like a Piping Plan 52. The barrier liquid may become contaminated with the pumped process liquid possibly creating a hazardous barrier liquid and increase the possibility of seal failure.

For general recommendations on piping practices and reservoir details, see Figure G.35, Figure G.36, and Figure G.38.

G.19 Piping Plan 53B

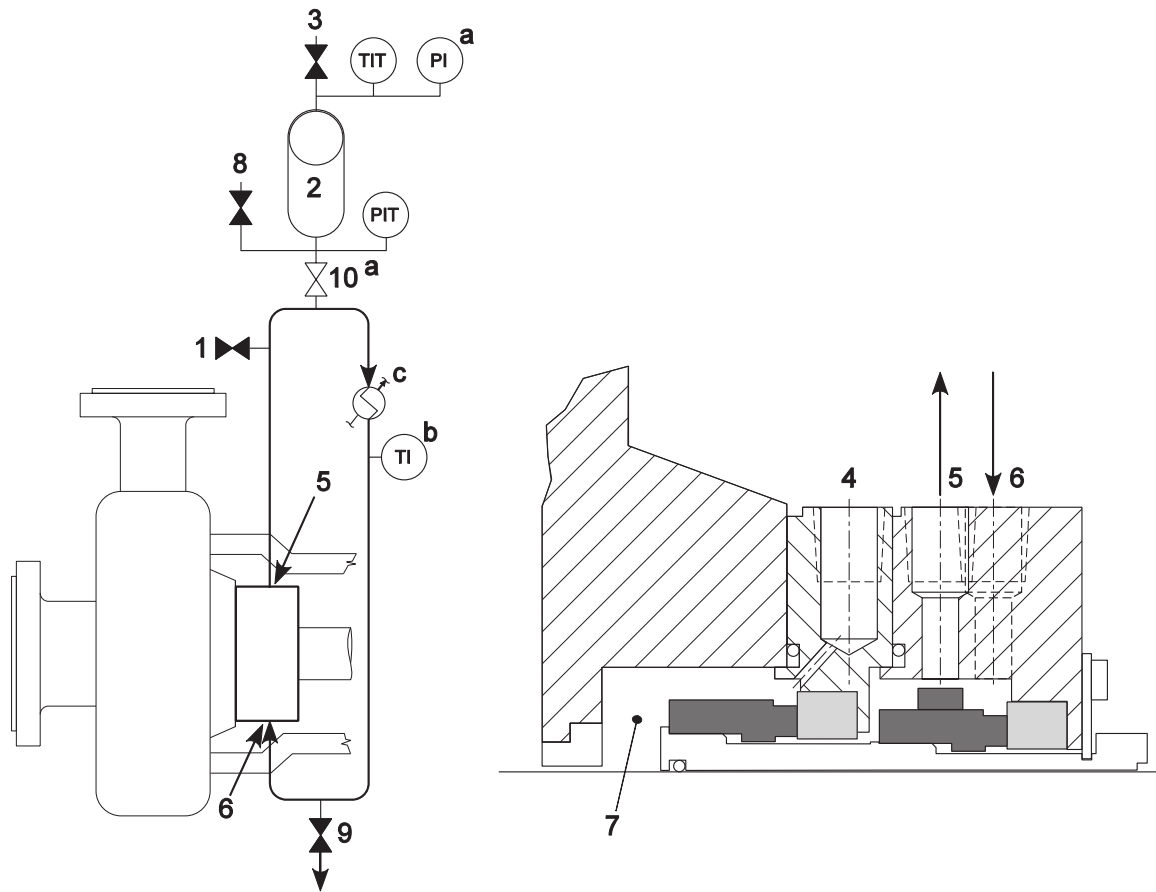

a) Piping and Instrumentation Schematic

b) Seal Chamber Details

Key

- | | | | |
|---|---------------------------|-----|--|
| 1 | make-up barrier liquid | 8 | vent |
| 2 | bladder accumulator | 9 | barrier fluid drain |
| 3 | bladder charge connection | 10 | valve (for checking accumulator bladder integrity) |
| 4 | flush (F) | PI | pressure indicator |
| 5 | liquid barrier out (LBO) | PIT | pressure transmitter with local indicator |
| 6 | liquid barrier in (LBI) | TI | temperature indicator |
| 7 | seal chamber | TIT | temperature transmitter local indicator |
- a If specified, both the PI and valve 10 shall be installed for checking bladder integrity.
- b If specified.
- c Vertically oriented, finned air cooler shall be installed if specified.

Figure G.19—Standard Seal Piping Plan 53B

In Piping Plan 53B, there is an external barrier fluid system pressurized by a bladder accumulator supplying clean liquid to the barrier fluid seal chamber. The accumulator and barrier liquid are maintained at a pressure greater than seal chamber pressure.

Barrier liquid is circulated through the system by means of an internal circulating device. To maximize barrier liquid circulation, the piping losses should be minimized through the proper selection of pipe size, elimination of fittings, use of large radius bends, and reduction in the length of piping runs.

Piping Plan 53B is used with an Arrangement 3 liquid seal and differs from Piping Plan 53A in that pressure is maintained in the barrier liquid system through the use of a bladder-type accumulator. The use of an accumulator prevents contact between the pressurization gas and the barrier liquid. This prevents gas absorption into the barrier liquid and allows for high-pressure operation. The accumulator is precharged prior to filling the system with barrier liquid and is brought to operating pressure by compressing the bladder in the accumulator as the system is filled with barrier liquid. Leakage past the inner and outer seals results in a decrease in the barrier system pressure. This requires that the barrier system be pressurized to a higher initial pressure and allowed to “leak” down to the minimum allowable system pressure. At this time, the system would be refilled to restore the maximum working barrier liquid volume. Seal performance is therefore monitored by pressure decrease and not by barrier liquid level as in Piping Plan 53A. For specific recommendations on pressurization, operation, and monitoring of Piping Plan 53B systems, refer to Annex F.

Effective flow of the Piping Plan 53B system is only achieved with proper exclusion of all gas and air bubbles from the seal cooler and piping. Venting of the system during commissioning is critical to proper operation.

For additional considerations between using a Piping Plan 53 and a Piping Plan 52, see G.18 Piping Plan 53A.

G.20 Piping Plan 53C

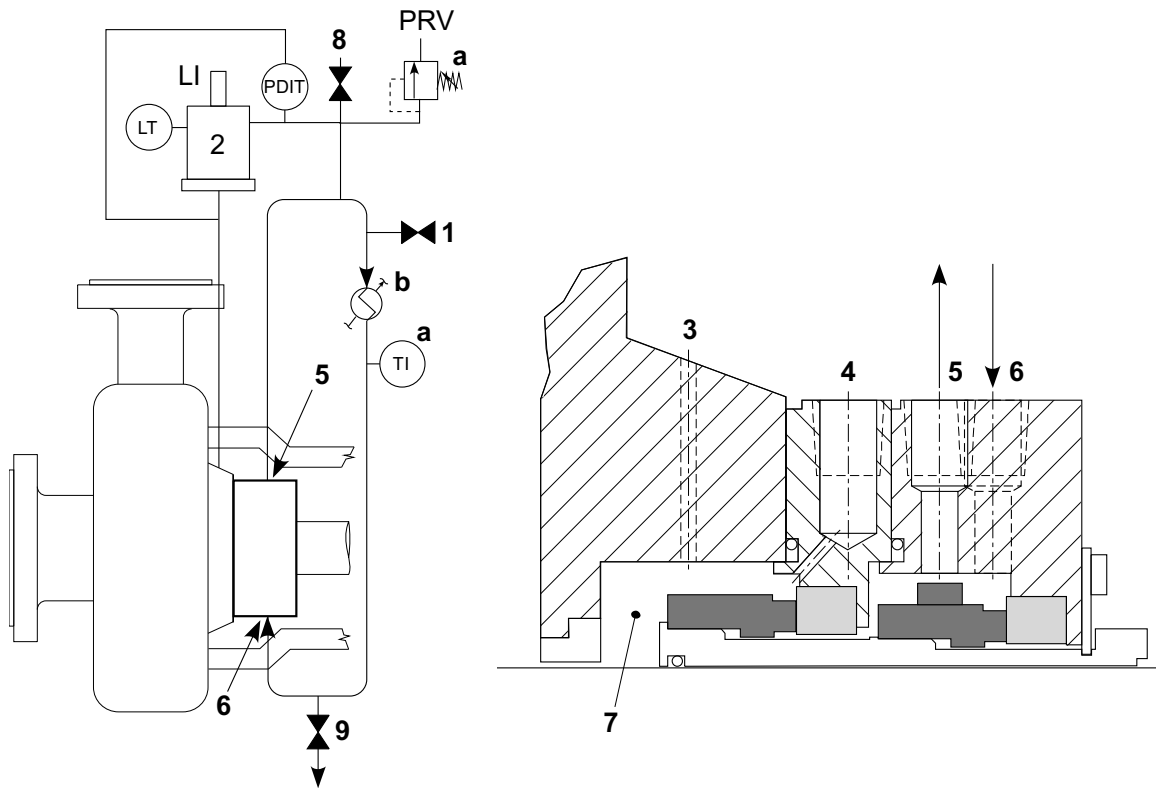

a) Piping and Instrumentation Schematic

b) Seal Chamber Details

Key

1	make-up buffer liquid	LI	level indicator
2	piston accumulator	LT	level transmitter
3	pressure reference	PRV	pressure relief valve
4	flush (F)	PDIT	differential pressure transmitter with local indicator
5	liquid barrier out (LBO)	TI	temperature indicator
6	liquid barrier in (LBI)		
7	seal chamber		
8	vent		
9	barrier fluid drain		

a If specified.

b Vertically oriented, finned air cooler may be provided if specified.

Figure G.20—Standard Seal Piping Plan 53C

In Piping Plan 53C, there is an external barrier fluid system pressurized by a piston accumulator supplying clean liquid to the barrier fluid seal chamber. The barrier liquid is maintained at a pressure greater than seal chamber pressure.

Barrier liquid is circulated through the system by means of an internal circulating device. To maximize barrier liquid circulation, the piping losses should be minimized through the proper selection of pipe size, elimination of fittings, use of large radius bends, and reduction in the length of piping runs.

Piping Plan 53C is used with an Arrangement 3 liquid seal and differs from Piping Plan 53A in that pressure is maintained in the barrier liquid through the use of a piston accumulator. The piston accumulator senses pressure from a reference source (normally a line connected to the seal chamber) and creates a higher pressure through differential areas in the piston. This high pressure creates the required pressure differential necessary for an Arrangement 3 seal. Since the barrier pressure is generated from the seal chamber pressure, the system is self-energizing and reacts to fluctuations in the seal chamber fluid pressure.

To create the reference pressure in the piston transmitter, process fluid is introduced into the piston. This requires that the materials used in the piston transmitter are compatible with the process fluid. Process fluids that contains solids, tend to plate out on metal surfaces, or solidify under atmospheric temperatures are not suitable for a Piping Plan 53C.

Effective flow of the Piping Plan 53C system is only achieved with proper exclusion of all gas and air bubbles from the seal cooler and piping. Venting of the system during commissioning is critical to proper operation. For specific recommendations on piping practices for Piping Plan 53C systems, refer to Annex F.

For additional considerations between using a Piping Plan 53 and a Piping Plan 52, see G.18 Piping Plan 53A.

G.21 Piping Plan 54

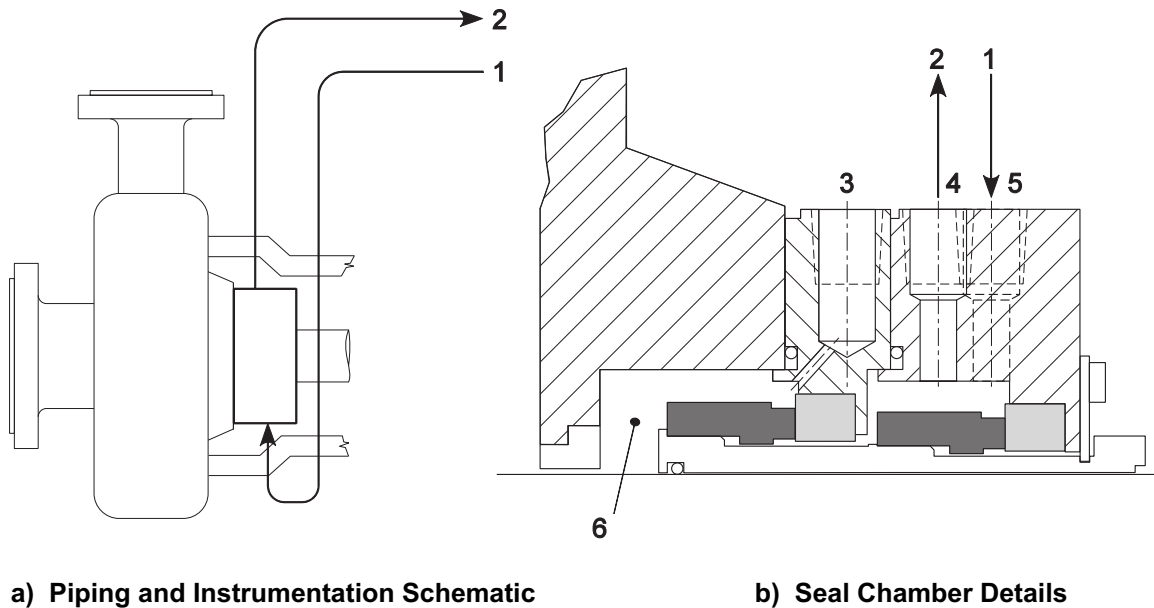

Key

- 1 from external source
- 2 to external source
- 3 flush (F)
- 4 liquid barrier out (LBO)
- 5 liquid barrier in (LBI)
- 6 seal chamber

Figure G.21—Standard Seal Piping Plan 54

In Piping Plan 54, there is a pressurized external barrier fluid system supplying clean liquid to the barrier fluid seal chamber. Piping Plan 54 is used with Arrangement 3 liquid seals and the barrier liquid is maintained at a pressure greater than seal chamber pressure. Barrier liquid is circulated by an external pump or pressure system. The design of the system including instrumentation, coolers, filters, and other components is outside the scope of this standard.

Piping Plan 54 systems are also pressurized dual-seal systems with inner seal leakage into the pumped product. In a Piping Plan 54, a cool clean product from an external source is supplied to the seal as a barrier liquid. The supply pressure of this product is at least 0.14 MPa (1.4 bar) (20 psi) greater than the pressure the inner seal is sealing against. This results in a small leakage of barrier fluid into the process. This plan with an Arrangement 3 seal should never be used where the barrier liquid pressure is less than the sealed pressure. If it were, the failure of one inner seal could contaminate the entire barrier liquid system and cause additional seal failures.

Piping Plan 54 is often used in services where the pumped fluid is hot, contaminated with solids, or the internal flow inducer is unable to supply a sufficient flow rate. If Piping Plan 54 is specified, carefully consider the reliability of the barrier liquid source. If the source is interrupted or contaminated, the resulting seal failures are very expensive to rectify. A properly engineered barrier liquid system is typically complex and often expensive. Where these systems are properly engineered, they provide among the most reliable systems.

G.22 Piping Plan 55

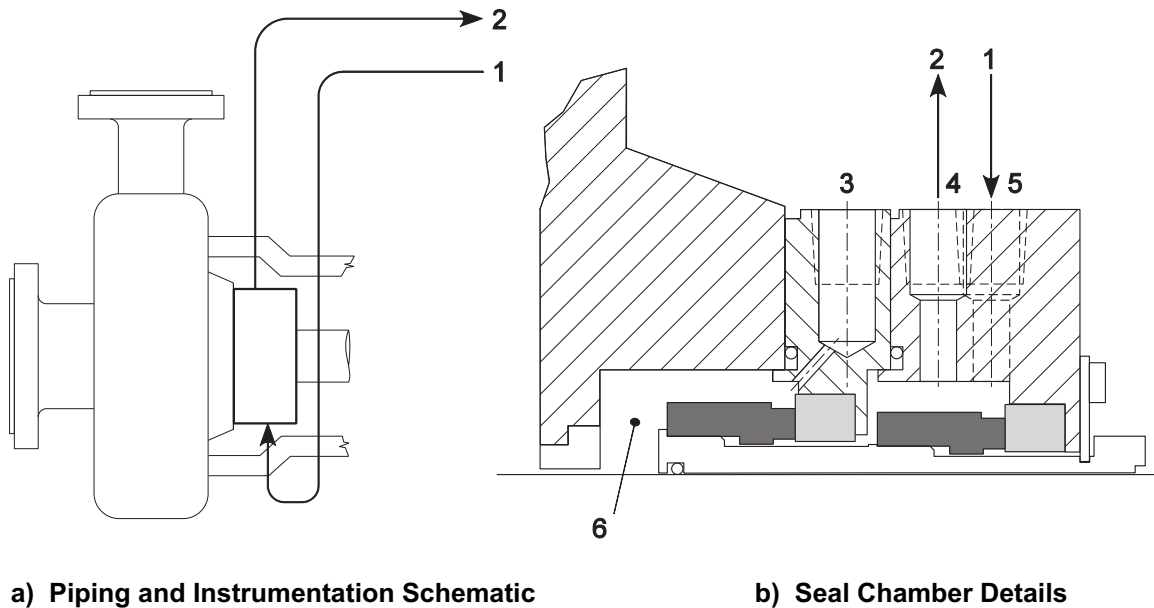

Key

- 1 from external source
- 2 to external source
- 3 flush (F)
- 4 liquid buffer out (LBO)
- 5 liquid buffer in (LBI)
- 6 seal chamber

Figure G.22—Standard Seal Piping Plan 55

In Piping Plan 55, there is an unpressurized external buffer fluid system supplying clean liquid to the buffer fluid seal chamber. Piping Plan 55 is used with Arrangement 2 liquid seals. The buffer liquid shall be maintained at a pressure less than seal chamber pressure and less than 0.28 MPa (2.8 bar) (40 psi). Buffer liquid is circulated by an external pump or pressure system.

Piping Plan 55 is similar to Piping Plan 54 except the buffer liquid is unpressurized. Piping Plan 55 is used with Arrangement 2 seals, with a contacting wet containment seal (configuration 2CW-CW) utilizing a liquid buffer system. It is normally used in services where process fluid leakage to atmosphere should be minimized and contained. It is also used in applications where the process may solidify in contact with atmosphere or in applications where additional heat removal from the inner seal is required.

Piping Plan 55 differs from a Piping Plan 52 in that the buffer liquid is not self-contained and the buffer liquid circulation is created by an external pump or pressure system. If Piping Plan 55 is specified, carefully consider the reliability of the buffer liquid source and the possible contamination of the buffer flow with process liquid or vapor.

G.23 Piping Plan 61

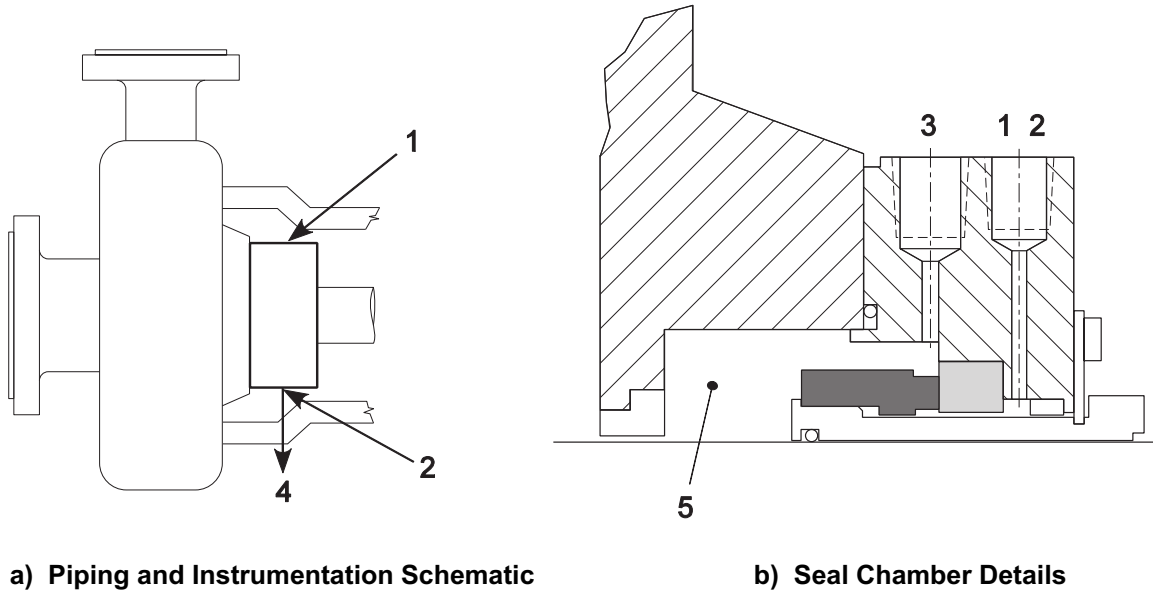

Key

- 1 quench (Q), plugged, metal
- 2 drain (D), open connected to metal tubing
- 3 flush (F)
- 4 to collection point
- 5 seal chamber

Figure G.23—Standard Seal Piping Plan 61

In Piping Plan 61 there are tapped and plugged atmospheric-side connections for purchaser's use.

In Piping Plan 61, all ports are plugged with plastic plugs at the time of shipment. At installation, the user shall connect tubing to the drain port and direct leakage to a collection point. This plan may also be specified if the purchaser may use these ports in the future.

G.24 Piping Plan 62

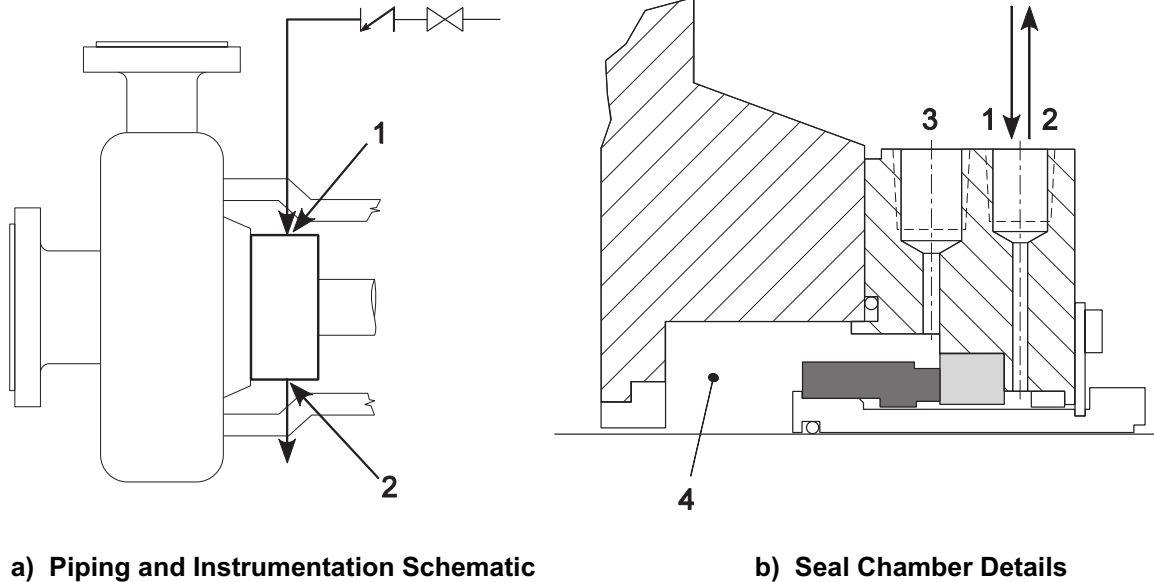

Key

- 1 quench (Q)
- 2 drain (D)
- 3 flush (F)
- 4 seal chamber

Figure G.24—Standard Seal Piping Plan 62

In Piping Plan 62, a quench stream is brought from an external source to the atmospheric side of the seal faces. The quench stream can be low-pressure steam, nitrogen, or clean water. It is used in selected single seal applications to exclude the presence of oxygen to prevent coke formation (for example, hot hydrocarbon services) and to flush away undesirable material buildup around the dynamic seal components (for example, caustic and salt services).

Piping Plan 62 is most effective when used with a close clearance bushing or containment device in the seal gland. This bushing not only contains the quench in the seal gland but also provides protection for the operator if a high-temperature quench is used. The drain port outlet should be larger than the quench port inlet. The drain port shall be sized to allow drainage of the quench medium.

G.25 Piping Plan 65A

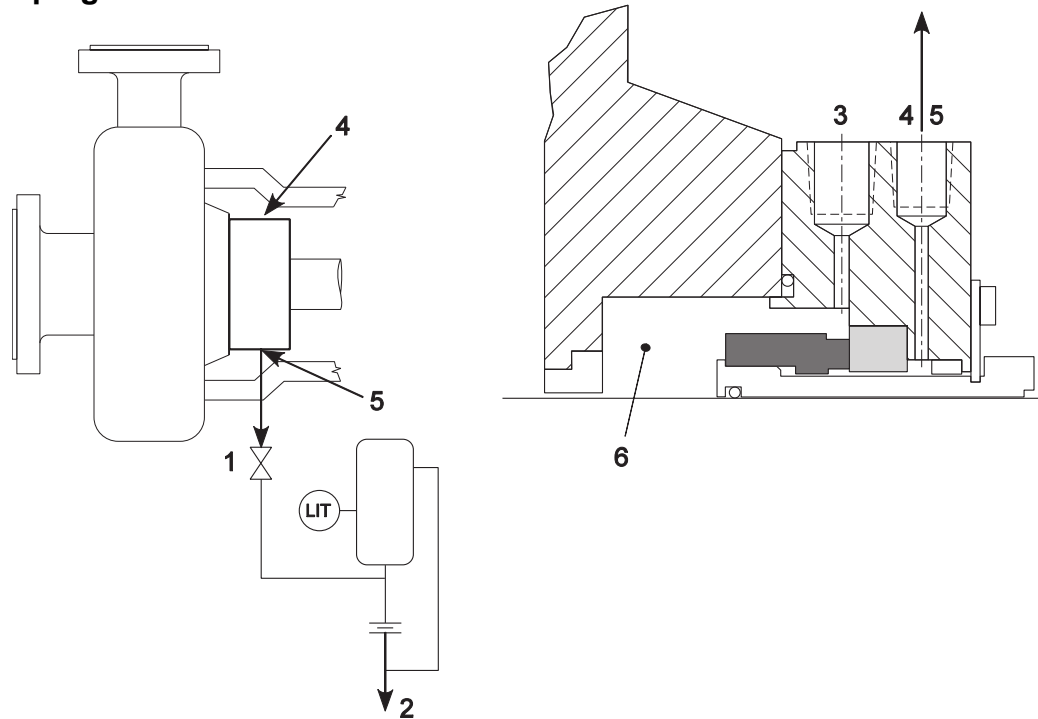

a) Piping and Instrumentation Schematic

b) Seal Chamber Details

Key

- 1 valve (locked open)
- 2 to liquid collection system
- 3 flush (F)
- 4 quench (Q)
- 5 drain (D)
- 6 seal chamber
- LIT level transmitter with local indicator

Figure G.25—Standard Seal Piping Plan 65A

In Piping Plan 65A there is an atmospheric leakage collection and detection system for condensing leakage. Failure of the seal will be detected by an excessive flow rate into the leakage collection system. This plan is used when pumped fluid condenses at ambient temperatures.

Piping Plan 65A is a seal leakage detection piping plan normally used with Arrangement 1 seals in services where seal leakage is expected to be mostly liquid (not gas). Piping is connected to the drain connection in the gland plate and directs any seal leakage past or through a reservoir and then through an orifice, exiting into an oil and water sewer or liquid collection system. Excessive flow rates would be restricted by the orifice located downstream of the reservoir and are redirected to it, causing the level transmitter to activate an alarm. The orifice, typically 5 mm (0.25 in.), should be located in a vertical piping leg to avoid accumulation of fluid in the drain piping. A connection on the reservoir above the level transmitter is connected to a pipe bypassing the orifice allowing excessive leakage to be effectively drained. A pressure transmitter can be provided as an option to allow for monitoring pressure increase in the system.

Piping Plan 65A is most effective when used with a floating or segmented bushing or containment device in the seal gland. The reservoir shall be mounted below the seal gland to allow leakage to flow to the reservoir.

Valve 1 shall be left open during operation and may be closed only for maintenance of the piping plan.

G.26 Piping Plan 65B

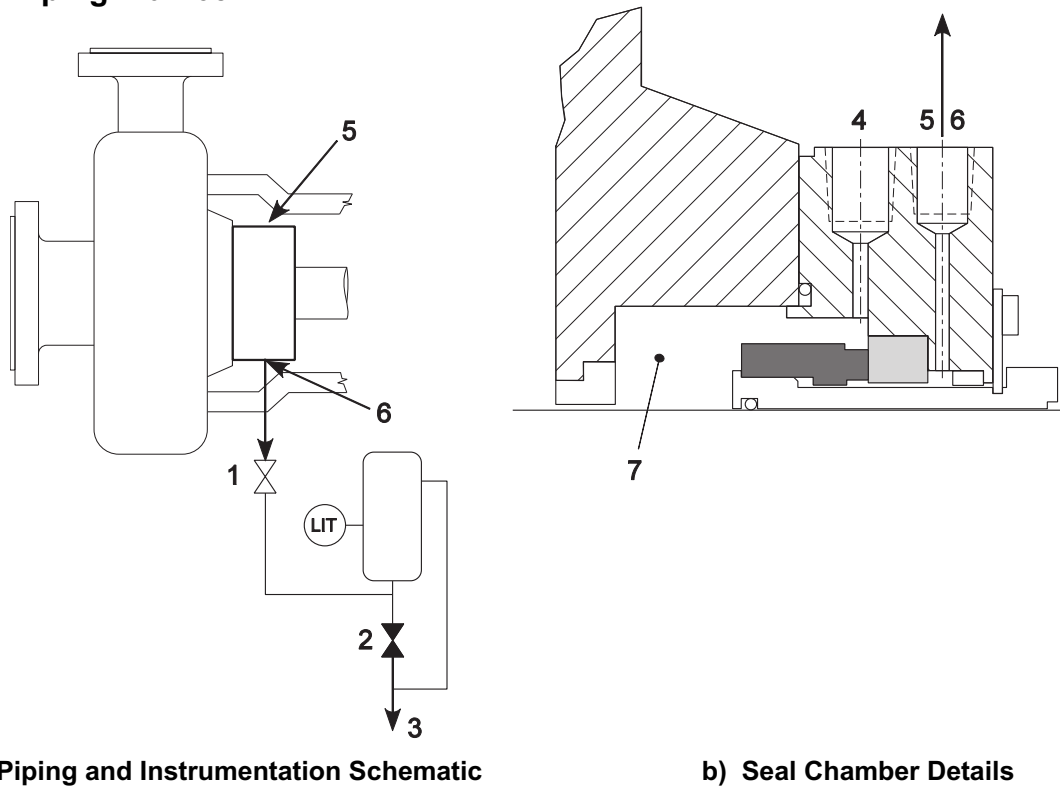

Key

- 1 valve (locked open)
- 2 drain valve
- 3 to liquid collection system
- 4 flush (F)
- 5 quench (Q)
- 6 drain (D)
- 7 seal chamber
- LIT level transmitter with local indicator

Figure G.26—Standard Seal Piping Plan 65B

In Piping Plan 65B there is an atmospheric leakage collection and detection system for condensing leakage. Failure of the seal will be detected by a cumulative leakage into the system. This plan is used when pumped fluid condenses at ambient temperatures.

Piping Plan 65B is a seal leakage detection piping plan normally used with Arrangement 1 seals in services where seal leakage is expected to be mostly liquid (not gas). Piping is connected to the drain connection in the gland plate and directs any seal leakage into a reservoir resulting in an increase in level of process fluid in the reservoir. The level increases will be monitored by the level transmitter and will activate an alarm. A connection on the reservoir above the transmitter is connected to a pipe bypassing the valve allowing excessive leakage to be effectively drained.

Piping Plan 65B is most effective when used with a floating or segmented bushing or containment device in the seal gland. The reservoir shall be mounted below the seal gland to allow leakage to flow to the reservoir.

Valve 1 shall be left open during operation and may be closed only for maintenance of the piping plan. Valve 2 shall normally be closed during operation although it may be opened periodically to allow collected leakage to be drained.

G.27 Piping Plan 66A

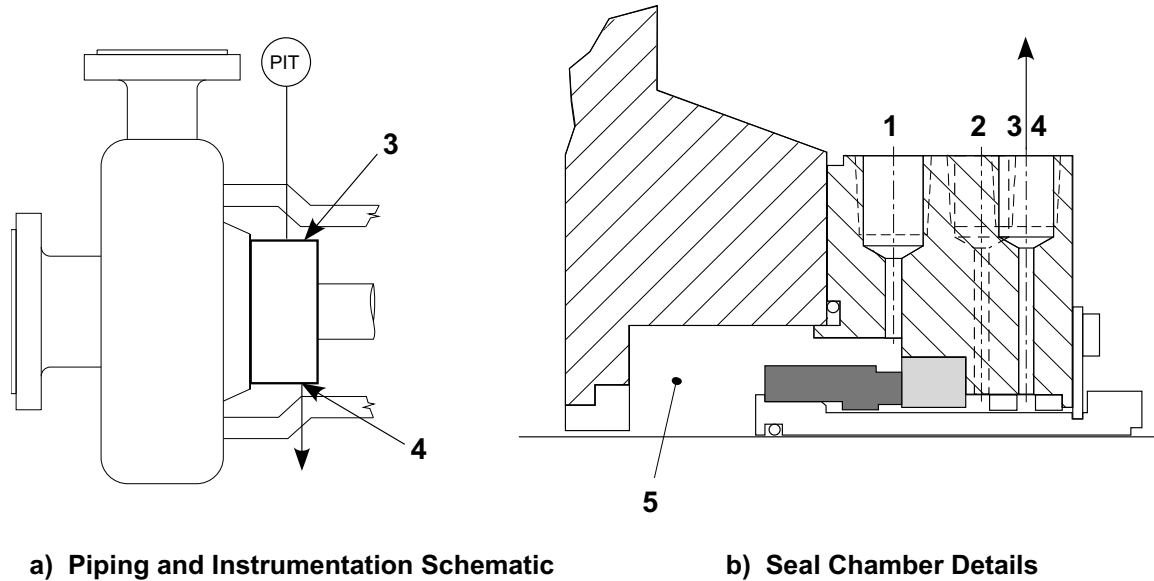

Key

1	flush (F)
2	pressure transmitter sensing port (PIT)
3	quench (Q)
4	drain (D)
5	seal chamber
PIT	pressure transmitter with local indicator

Figure G.27—Standard Seal Piping Plan 66A

In Piping Plan 66A, the throttle bushings in the seal gland minimize the seal leakage leaving the seal gland and allow for detection of a seal failure.

Piping Plan 66A is intended for use in Arrangement 1 applications where it is required to limit leakage in case of a seal failure or it is required to monitor excessive leakage. In this plan, normal seal leakage can flow freely to the drain port. If the seal leakage is excessive however, the inner bushing will restrict the flow to the drain and limit the amount of leakage leaving the seal gland. As the leakage rate increases, the pressure will increase on the upstream side of the inner bushing. This pressure will be monitored by the pressure transmitter and can be used to monitor seal performance and trigger an alarm indicating a seal failure. Leakage out of the drain port is collected and piped to a liquid recovery system or sump. See 7.1.2.3 for additional details.

NOTE This plan is most commonly used on pipeline applications.

G.28 Piping Plan 66B

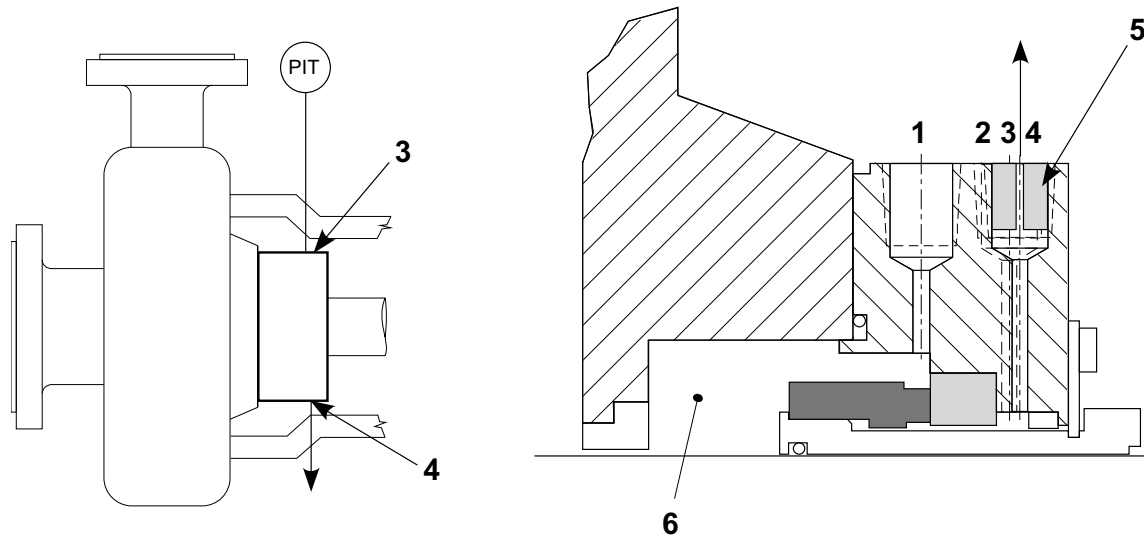

a) Piping and Instrumentation Schematic

b) Seal Chamber Details

Key

- 1 flush (F)
- 2 pressure transmitter sensing port (PIT)
- 3 quench (Q)
- 4 drain (D), with orifice plug installed
- 5 orifice plug
- 6 seal chamber
- PIT pressure transmitter with local indicator

Figure G.28—Standard Seal Piping Plan 66B

In Piping Plan 66B, an orifice plug in the drain port minimizes the seal leakage leaving the seal gland and allows for detection of a seal failure.

Piping Plan 66B is intended for use in Arrangement 1 applications where it is required to limit leakage in case of a seal failure or it is required to monitor excessive leakage. In this plan, normal seal leakage can flow freely out the drain port. If the seal leakage is excessive however, the orifice plug in the drain limits the amount of leakage leaving the seal gland. As the leakage rate increases, the pressure will increase on the upstream side of the orifice plug. This pressure will be monitored by the pressure transmitter and can be used to monitor seal performance and trigger an alarm indicating a seal failure. Since the drain cavity will become pressurized, a floating throttle bushing should be used to limit leakage past the bushing. Leakage out of the drain port is collected and piped to a liquid recovery system or sump. See 7.1.2.3 for additional details.

NOTE This plan is most commonly used on pipeline applications.

G.29 Piping Plan 71

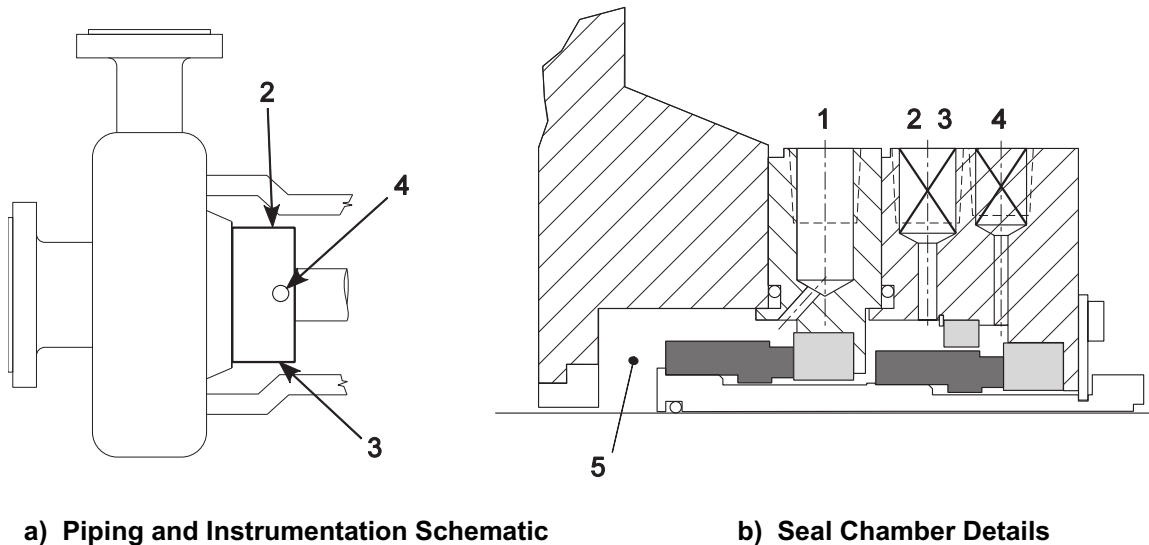

Key

- 1 flush (F)
- 2 containment seal vent (CSV), plugged
- 3 containment seal drain (CSD), plugged
- 4 gas buffer inlet (GBI), plugged
- 5 seal chamber

Figure G.29—Standard Seal Piping Plan 71

In Piping Plan 71 there are tapped connections for the purchaser's use. All ports shall be plugged with plastic plugs at the time of shipment. At installation, the user shall remove all plastic plugs and all ports shall either be connected to tubing or plugged with metal plugs as described in 8.2.19. Typically, this plan is used if the purchaser might use buffer gas in the future.

Piping Plan 71 is used on Arrangement 2, unpressurized dual seals, which utilize a dry containment seal and where no buffer gas is supplied but the provision to supply a buffer gas is desired. Buffer gas may be needed to sweep inner seal leakage away from the outer seal into a collection system or to dilute the leakage but is not specified.

G.30 Piping Plan 72

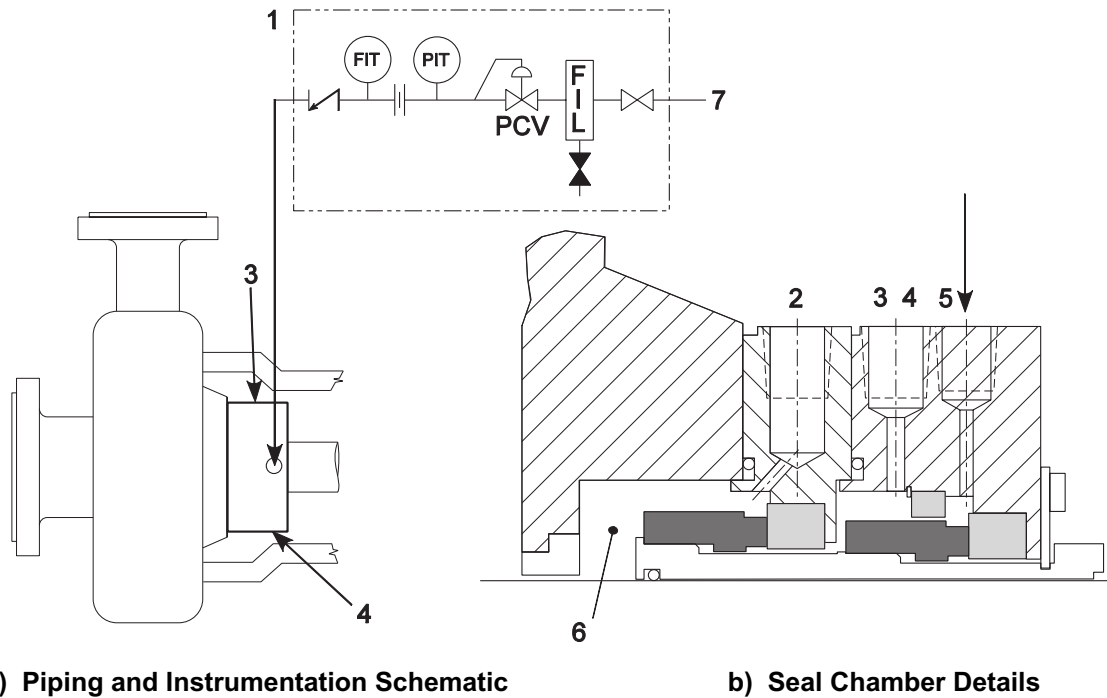

Key

1	buffer gas panel	FIL	coalescing filter
2	flush (F)	FIT	flow transmitter with local indicator
3	containment seal vent (CSV)	PCV	pressure control valve
4	containment seal drain (CSD)	PIT	pressure transmitter with local indicator
5	gas buffer inlet (GBI)		
6	seal chamber		
7	from buffer gas supply		

Figure G.30—Standard Seal Piping Plan 72

In Piping Plan 72 there is externally supplied buffer gas for Arrangement 2 seals. Buffer gas is maintained at a pressure less than seal chamber pressure. In normal operation, the buffer gas pressure should not exceed 0.07 MPa (0.7 bar) (10 psi).

Piping Plan 72 can be used on Arrangement 2 unpressurized dual seals that use a dry-running containment seal. This plan may be used alone or in conjunction either a Piping Plan 75 or Piping Plan 76. The buffer gas can be used to sweep inner-seal leakage away from the outer seal to a collection system and/or dilute the leakage so the emissions from the containment seal are reduced.

The Piping Plan 72 system is intended to function as follows: from the source supply provided by the plant operator, the buffer gas enters the system, mounted on a plate or panel, provided by the seal vendor. A coalescing filter to remove any particles and liquid that might be present follows an inlet block valve on the panel. The gas then flows through a forward-pressure regulator that is set at the Piping Plan 75 or Piping Plan 76 alarm point, or at least 0.04 MPa (0.4 bar) (5 psi) above the normal flare pressure. Next comes a pressure transmitter with a local indicator ahead of an orifice; these are used to set the regulator. They also ensure the source pressure always maintains a flush flow over the operating range of the combined systems (when used with Piping Plan 75 or Piping Plan 76) and does not pressurize the seal chamber or affect the alarm settings of the exit flush plan. The orifice provides flow regulation and is followed by a flow transmitter to measure flow. The orifice also serves to control buffer gas loss in the event of an outer seal failure. (The use of a needle or globe valve for the orifice to allow flow regulation is optional.) The flow transmitter with a local indicator will display buffer gas flow rate and alarm on high flow. The last element on the panel is a check valve. Buffer gas is then routed through tubing to the seal.

G.31 Piping Plan 74

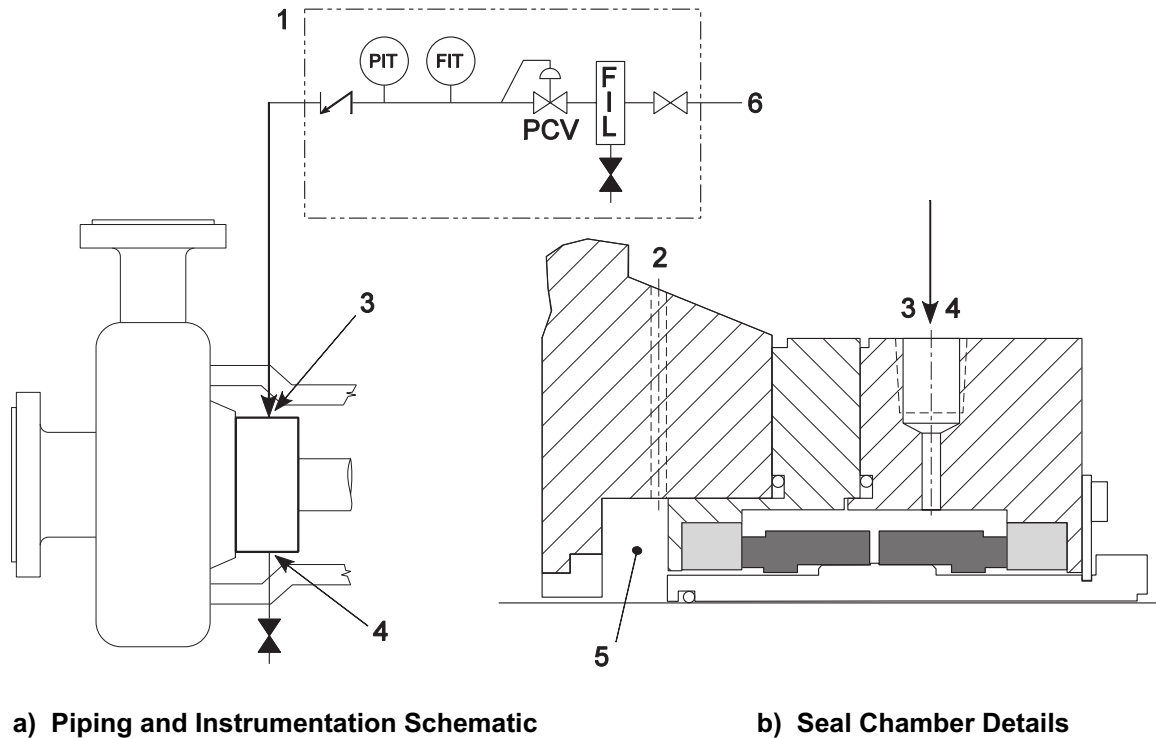

Key

1	barrier gas panel	FIL	coalescing filter
2	vent (if required)	FIT	flow transmitter with local indicator
3	gas barrier inlet (GBI)	PCV	pressure control valve
4	gas barrier outlet (GBO) (normally closed), used only to depressurize barrier	PIT	pressure transmitter with local indicator
5	seal chamber		
6	from barrier gas supply		

Figure G.31—Standard Seal Piping Plan 74

In Piping Plan 74 there is externally supplied barrier gas for Arrangement 3 seals. Barrier gas is maintained at a pressure greater than seal chamber pressure.

Piping Plan 74 systems are used on Arrangement 3, dual pressurized seals, where the barrier medium is a gas. They are the gas barrier equivalent to the traditional Piping Plan 54 liquid barrier system. The most common barrier gas is plant nitrogen. The supply pressure to the seal is typically at least 0.17 MPa (1.7 bar) (25 psi) greater than the seal chamber pressure. This results in a small amount of gas leakage into the pump, with most of the gas barrier leaking to atmosphere. This arrangement should never be used where the barrier-gas pressure can be less than the sealed pressure. If this were to happen, the entire barrier gas system could become contaminated with the pumped fluid.

Piping Plan 74 systems are typically used in services that are not too hot (within elastomer property limits) but that may contain toxic or hazardous materials whose leakage cannot be tolerated. Because they are pressurized dual seal systems, leakage to the atmosphere is eliminated under normal conditions. Piping Plan 74 may also be used to obtain very high reliability, since solids or other materials that can lead to premature seal failure cannot enter the seal faces. For services containing sticky or polymerizing agents or

where dehydration of the pumpage causes solids buildup, Piping Plan 74 systems are not generally recommended.

The Piping Plan 74 system is intended to function as follows:

- from the source supply provided by the plant operator;
- the buffer gas enters the system;
- mounted on a plate or panel, provided by the seal vendor.

An inlet block valve on the panel is followed by a 2 μm to 3 μm filter coalescing filter to remove any particles and liquid that might be present. The gas then flows through a pressure regulator that is set at least 0.17 MPa (1.7 bar) (25 psi) greater than the seal chamber pressure. The flow transmitter with a local indicator follows the regulator and is used to measure the flow and alarm at excessive flow. The next element is a pressure transmitter with a local indicator that is used to confirm adequate pressure. The pressure transmitter is used to raise an alarm upon loss of barrier gas pressure. The last elements on the panel is a check valve. Barrier gas is then routed to the seal using tubing.

No orifice is used in the barrier gas panel to help insure barrier pressure is maintained during high flow rates. For pumps requiring more than one seal assembly (e.g. between bearing pumps), each seal shall be provided with a separate barrier gas panel so failure of one seal assembly will not compromise the performance of the other seal.

The barrier gas shall be pressurized prior to filling the pump and maintained at all times including standby operation. During standby, small amounts of leakage will continue to leak past the inner seal and collect in the pump. This may require venting the pump prior to starting the pump.

G.32 Piping Plan 75

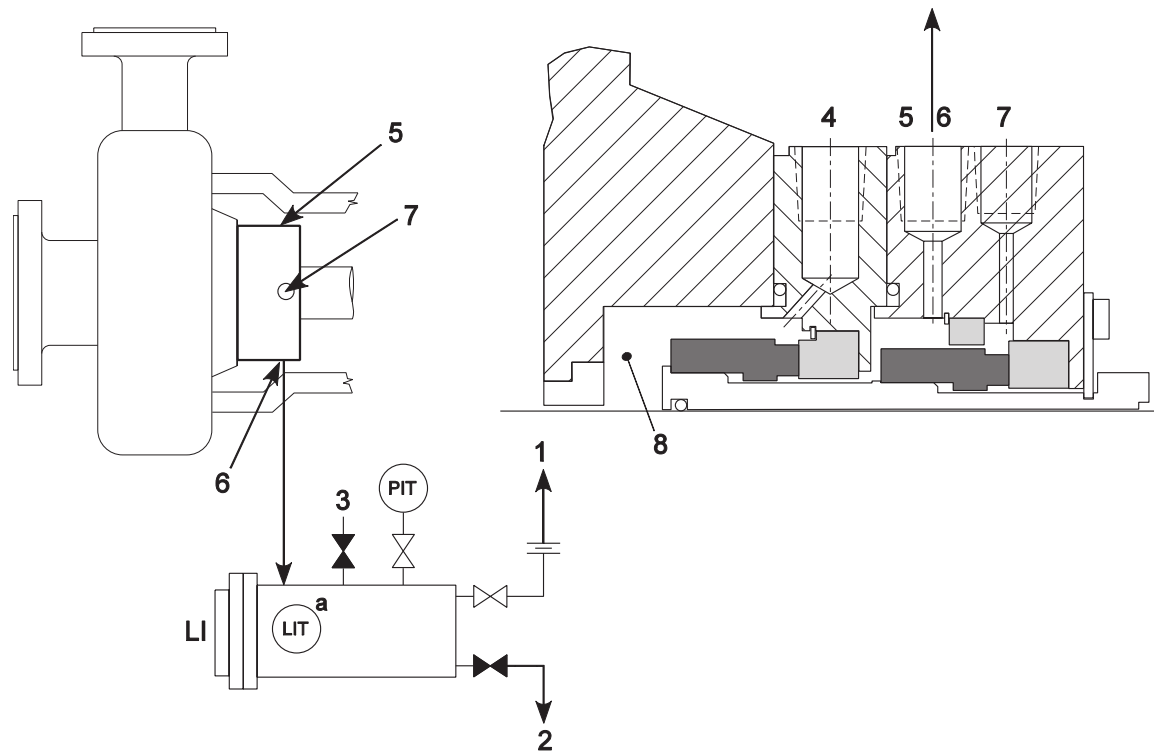

a) Piping and Instrumentation Schematic

b) Seal Chamber Details

Key

- | | | | |
|---|--------------------------------------|-----|---|
| 1 | to vapor collection system | 7 | gas buffer inlet (GBI), plugged unless used with a Piping Plan 72 |
| 2 | to liquid collection system | 8 | seal chamber |
| 3 | test connection (if specified) | LI | level indicator |
| 4 | flush (F) | LIT | level transmitter with local indicator |
| 5 | containment seal vent (CSV), plugged | PIT | pressure transmitter with local indicator |
| 6 | containment seal drain (CSD) | | |

^a If specified.

Figure G.32—Standard Seal Piping Plan 75

In Piping Plan 75 there is a containment seal chamber leakage collection system for condensing or mixed phase leakage on Arrangement 2 seals. This plan is used when pumped fluid condenses at ambient temperatures. This system is supplied by vendor.

Piping Plan 75 systems are typically used on Arrangement 2, unpressurized dual seals, which also utilize a dry containment seal and where the leakage from the inner seal may condense. They may be used with a buffer gas (Piping Plan 72) or without a buffer gas (Piping Plan 71).

If an unpressurized dual seal is installed, usually it is because leakage of the pumped fluid to the atmosphere should be restricted more than can be achieved with an Arrangement 1 seal. Therefore, a means is needed to collect the leakage and route it to a collection point. The Piping Plan 75 system is intended to

perform this collection function for pumped fluids that may form some liquid (condense) at ambient temperature.

NOTE Even if the pumped liquid does not condense, users may wish to install this system because of the risk of back-flow of condensation from the collection system.

Piping Plan 75 is intended to work as follows. Leakage from the inner seal is restricted from escape by the containment seal and routed into the drain line. The collector accumulates any liquid, while vapor passes through into the collection system. A level indicator on the collector is used to determine when the collector needs to be drained and the level transmitter will enable the user to monitor the liquid leakage rate. An orifice in the outlet line of the collector restricts flow such that high leakage of the inner seal will cause a pressure increase and trigger the pressure transmitter to alarm at a gauge pressure of 0.07 MPa (0.7 bar) (10 psi). The block valve in the outlet of the collector serves to isolate the collector for maintenance. It may also be used to test the inner seal by closing while the pump is in operation and noting the time/pressure buildup relationship in the collector. If specified, a connection on the collector may be used to inject nitrogen or other gas for the purpose of testing the containment seal.

The pressure transmitter in Piping Plan 75 will track the pressure in the vapor collection system. In normal operation, the pressure in the containment seal chamber can be as high as the vapor collection system pressure plus the check valve cracking pressure (if present). Pressures greater than this may indicate excessive leakage past the inner seal.

G.33 Piping Plan 76

Dimensions in millimeters (inches)

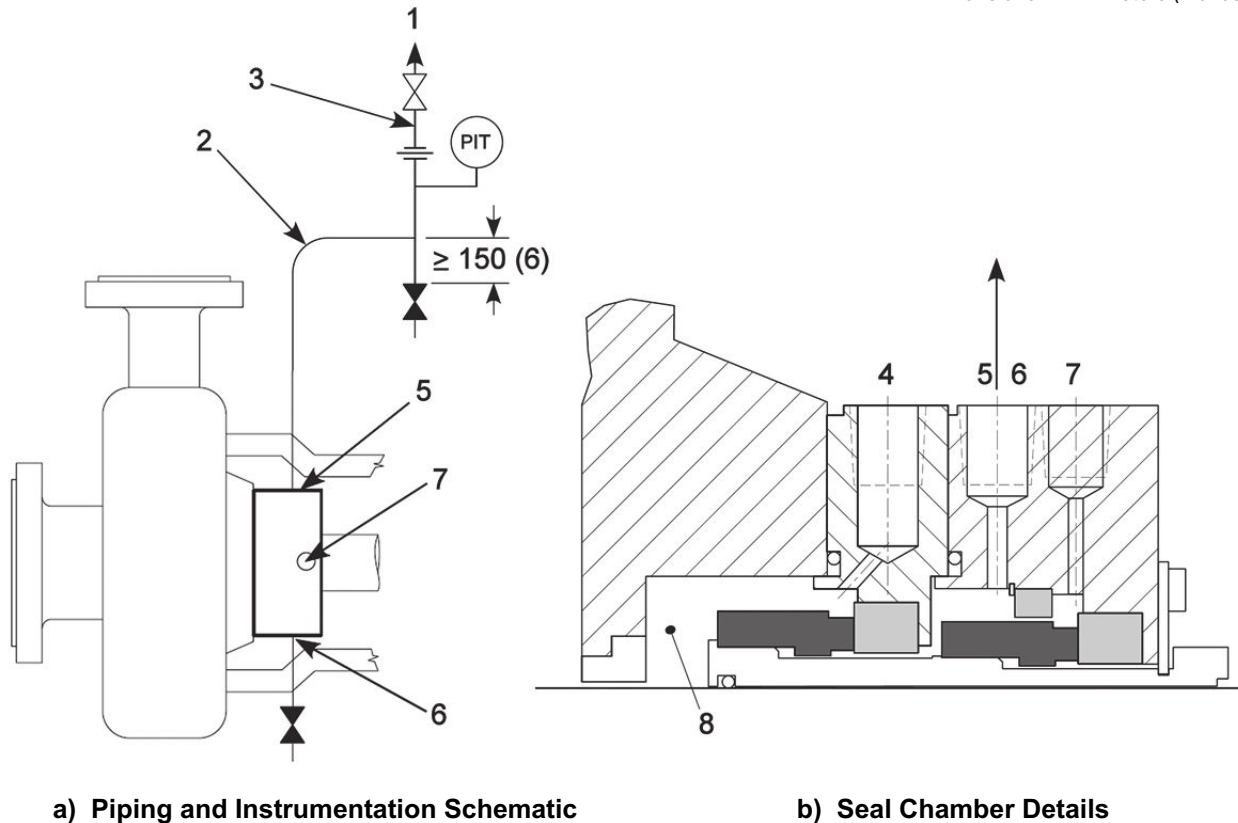

a) Piping and Instrumentation Schematic

b) Seal Chamber Details

Key

- 1 to vapor collection system
- 2 tube
- 3 pipe
- 4 flush (F)
- 5 containment seal vent (CSV)
- 6 containment seal drain (CSD), closed
- 7 gas buffer inlet (GBI), plugged unless used with a Piping Plan 72
- 8 seal chamber
- PIT pressure transmitter with local indicator

Figure G.33—Standard Seal Piping Plan 76

In Piping Plan 76 there is a containment seal chamber drain for noncondensing leakage on Arrangement 2 seals. This plan is used if the pumped fluid does not condense at ambient temperatures. This system is supplied by the vendor.

Tubing shall be 13 mm ($\frac{1}{2}$ in.) minimum diameter and shall rise continuously upward from the CSV connection to the piping/instrumentation harness.

The harness shall be pipe of minimum size DN 15 (NPS $\frac{1}{2}$). Harness shall be supported from overhead structure or side stand such that no strain is put on the tubing connection to the seal gland plate.

Piping Plan 76 systems are typically used on Arrangement 2, unpressurized dual seals, which also utilize a dry containment seal and where leakage from the inner seal will not condense. They may be used with a buffer gas (Piping Plan 72) or without a buffer gas (Piping Plan 71).

If an unpressurized dual seal is installed, usually it is because leakage of the pumped fluid to the atmosphere should be restricted more than can be achieved with an Arrangement 1 seal. Therefore, a means is needed to route the leakage to a collection point. The Piping Plan 76 system is intended for services where no condensation of the inner seal leakage or from the collection system will occur. Should liquid accumulate in the containment seal chamber, excessive heat could be generated, leading to hydrocarbon coking and possible seal failure.

Piping Plan 76 is intended to work as follows: leakage from the inner seal is restricted from escape by the containment seal and goes out the containment-seal vent. An orifice in the outlet line of the collector restricts flow such that high leakage of the inner seal will cause a pressure increase and trigger the pressure transmitter to alarm at a gauge pressure of 0.07 MPa (0.7 bar) (10 psi). The block valve in the outlet serves to isolate the system for maintenance. It may also be used to test the inner seal by closing while the pump is in operation and noting the time/pressure buildup relationship in the collector. A drain connection on the piping harness may be used to inject nitrogen or other gas for the purpose of testing the containment seal as well as for checking for any liquid buildup.

The pressure transmitter in Piping Plan 76 will track the pressure in the vapor collection system. In normal operation, the pressure in the containment seal chamber can be as high as the vapor collection system pressure plus the check valve cracking pressure (if present). Pressures greater than this may indicate excessive leakage past the inner seal.

G.34 Piping Plan 99

Engineered piping plan not defined by other existing plans.

In some challenging seal applications, it is necessary to design a piping plan for the specific characteristics of the seal, arrangement, process conditions or operating practices. The requirements for these applications may require modifications to existing piping plans or the creation of a new and unique plan.

Piping Plan 99 defines an engineered piping plan. The description and requirements for this piping plan shall be clearly defined in specifications outside of this standard. Wherever possible though applicable requirements within this standard should be applied to the new piping plan.

The decision to use a Piping Plan 99 may be made by either the purchaser or the supplier with purchaser's approval.

G.35 External Barrier/Buffer Fluid Reservoir

Figure G.35 shows the standard configuration of an external barrier/buffer fluid reservoir.

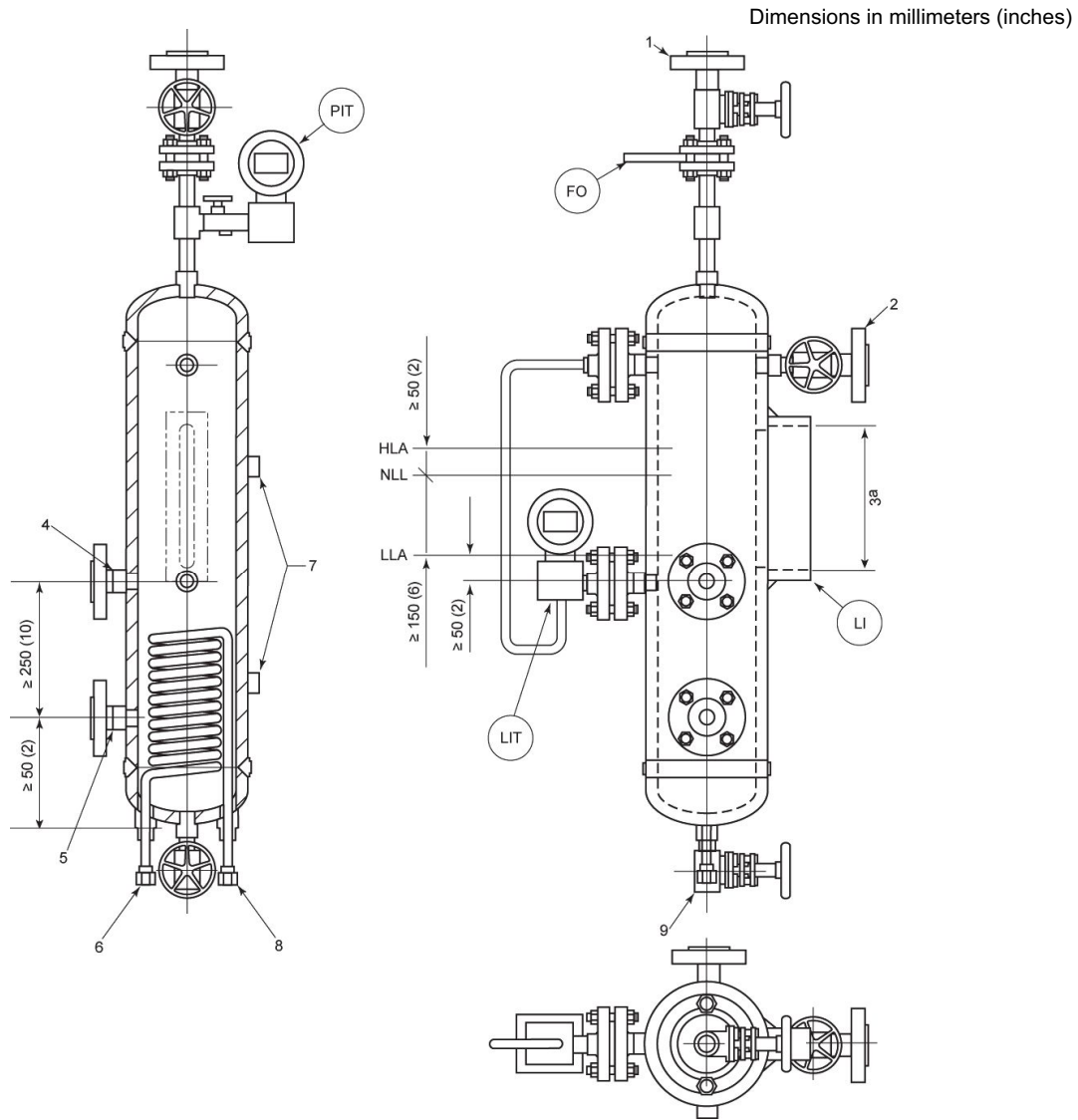

Key

- | | | | |
|---|-----------------------|-----|---|
| 1 | vent | FO | flow orifice |
| 2 | pressure fill | LI | level indicator |
| 3 | visible length | LIT | level transmitter with local indicator |
| 4 | return from seal | PIT | pressure transmitter with local indicator |
| 5 | supply to seal | HLA | high-level alarm set point |
| 6 | cooling liquid inlet | NLL | normal liquid level |
| 7 | mounting lugs | LLA | low level alarm set point |
| 8 | cooling liquid outlet | | |
| 9 | drain | | |

^a Visible length shall extend from below LLA to 75 mm (3.0 in.) above NLL or 25 mm (1.0 in.) above HLA, whichever is greater.

Figure G.35—Standard External Barrier/Buffer Fluid Reservoir

G.36 Alternate External Barrier/Buffer Fluid Reservoir

Figure G.36 shows an alternative configuration.

Dimensions in millimeters (inches)

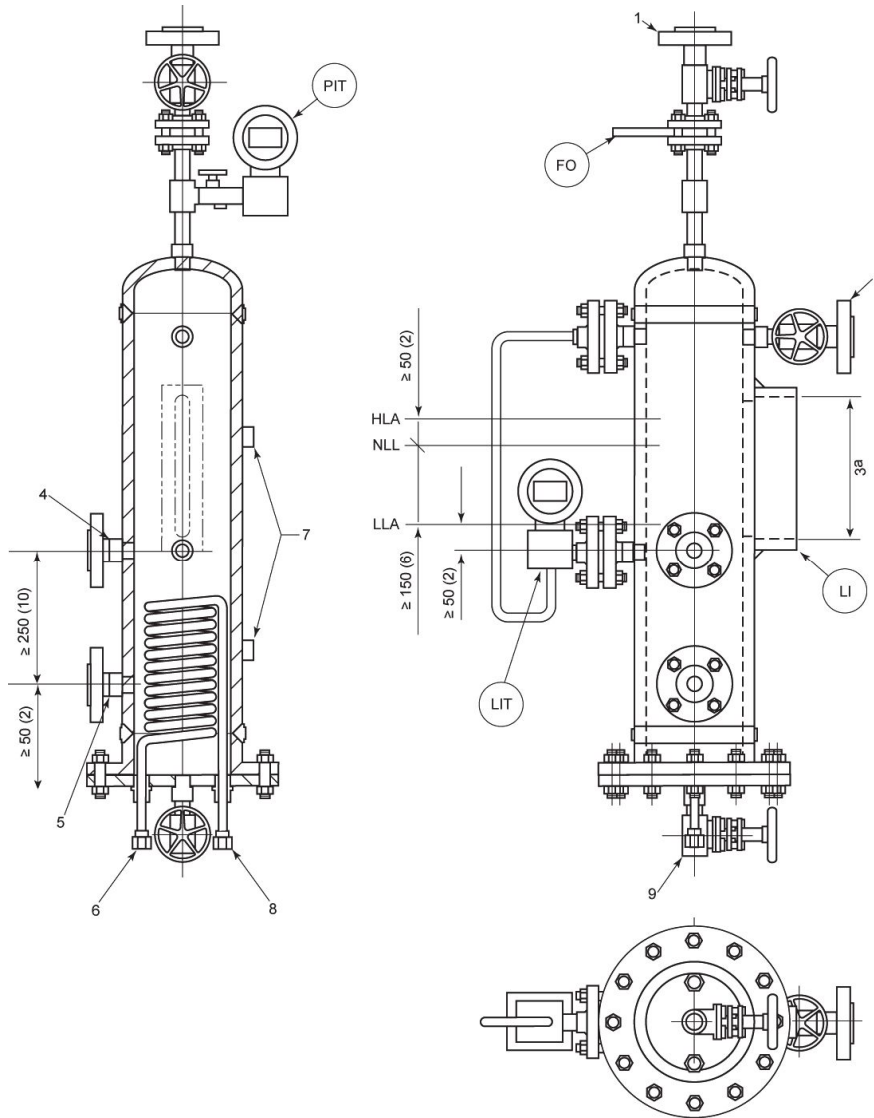

Key

- | | | | |
|---|---|-----|---|
| 1 | vent | FO | flow orifice |
| 2 | pressure fill | LI | level indicator |
| 3 | visible length | LIT | level transmitter with local indicator |
| 4 | return from seal | PIT | pressure transmitter with local indicator |
| 5 | supply to seal | HLA | high-level alarm set point |
| 6 | cooling liquid inlet | NLL | normal liquid level |
| 7 | mounting lugs | LLA | low level alarm set point |
| 8 | cooling liquid outlet | | |
| 9 | drain | | |
| a | Visible length shall extend from below LLA to 75 mm (3 in.) above NLL or 25 mm (1 in.) above HLA, whichever is greater. | | |

Figure G.36—Alternative External Barrier/Buffer Fluid Reservoir

G.37 Piping Plan 23 Circulation System

Figure G.37 shows a typical configuration for the installation of a Piping Plan 23 circulation system.

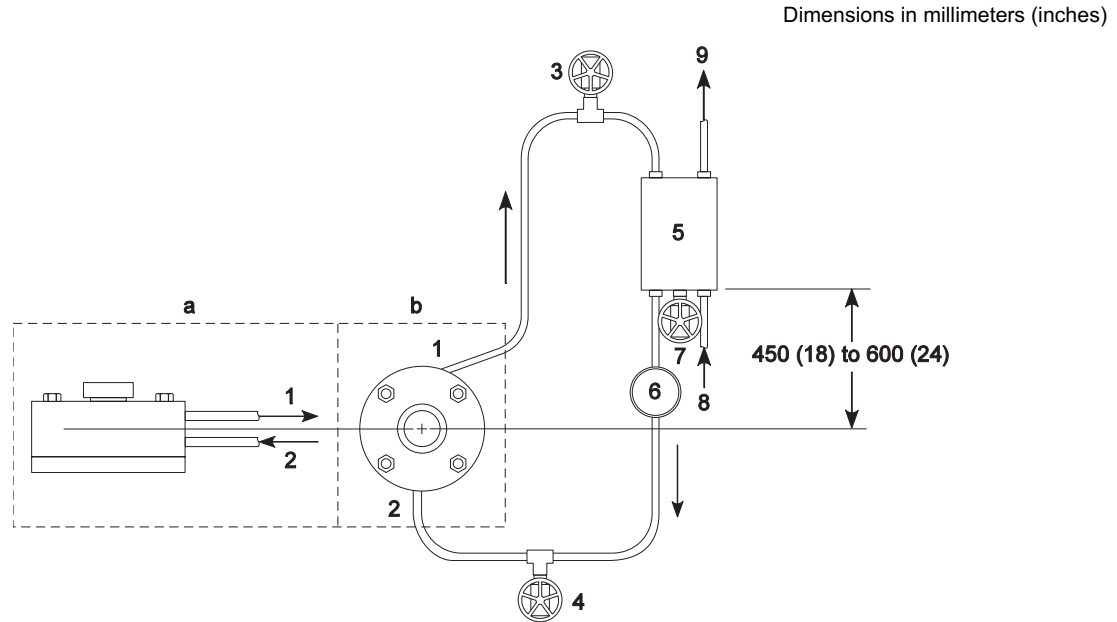

Key

- | | | | |
|---|--------------------------------------|---|-----------------------------|
| 1 | to seal cooler | 6 | temperature indicator |
| 2 | from seal cooler | 7 | cooling water service drain |
| 3 | high point vent in connecting tubing | 8 | cooling water inlet (CWI) |
| 4 | low point drain in connecting tubing | 9 | cooling water outlet (CWO) |
| 5 | seal flush cooler | | |
| a | For vertical applications. | | |
| b | For horizontal applications. | | |

Figure G.37—Typical Installation of a Piping Plan 23 Circulation System

The seal flush cooler shall have the cooling liquid on the shell side and the process fluid on the tube side. The cooler design and arrangement shall provide complete venting and draining of both the cooling liquid and process fluids. The cooler shall be mounted in accordance with the manufacturer's instructions to achieve this.

The seal cooler shall be located as close to the pump as possible while leaving sufficient room for operation and maintenance. It should not be located directly above the pump. To promote thermosyphoning, the seal cooler shall be located 450 mm to 600 mm (18 in. to 24 in.) above the centerline of the gland plate. Hot lines should be insulated as necessary for safety.

To reduce friction losses in tubing, smooth, long radius bends shall be used. For piping, the number of 90° elbows shall be minimized, although 45° elbows may be used.

All lines shall slope up from the gland to the high point vent; the slope shall be a minimum of 40 mm/m (0.5 in./ft). The seal cooler and all connecting tubing and piping shall be completely vented and free from air before the seal is put into operation.

NOTE Other piping plans using seal coolers, especially Piping Plan 53B and Piping Plan 53C, will benefit from using the same system design requirements as the Piping Plan 23 (e.g. sloping tubing, venting, and cooler location) except specific components in the system will differ.

G.38 Barrier/Buffer Fluid Reservoir

Figure G.38 shows a typical configuration for the installation of a barrier/buffer fluid reservoir.

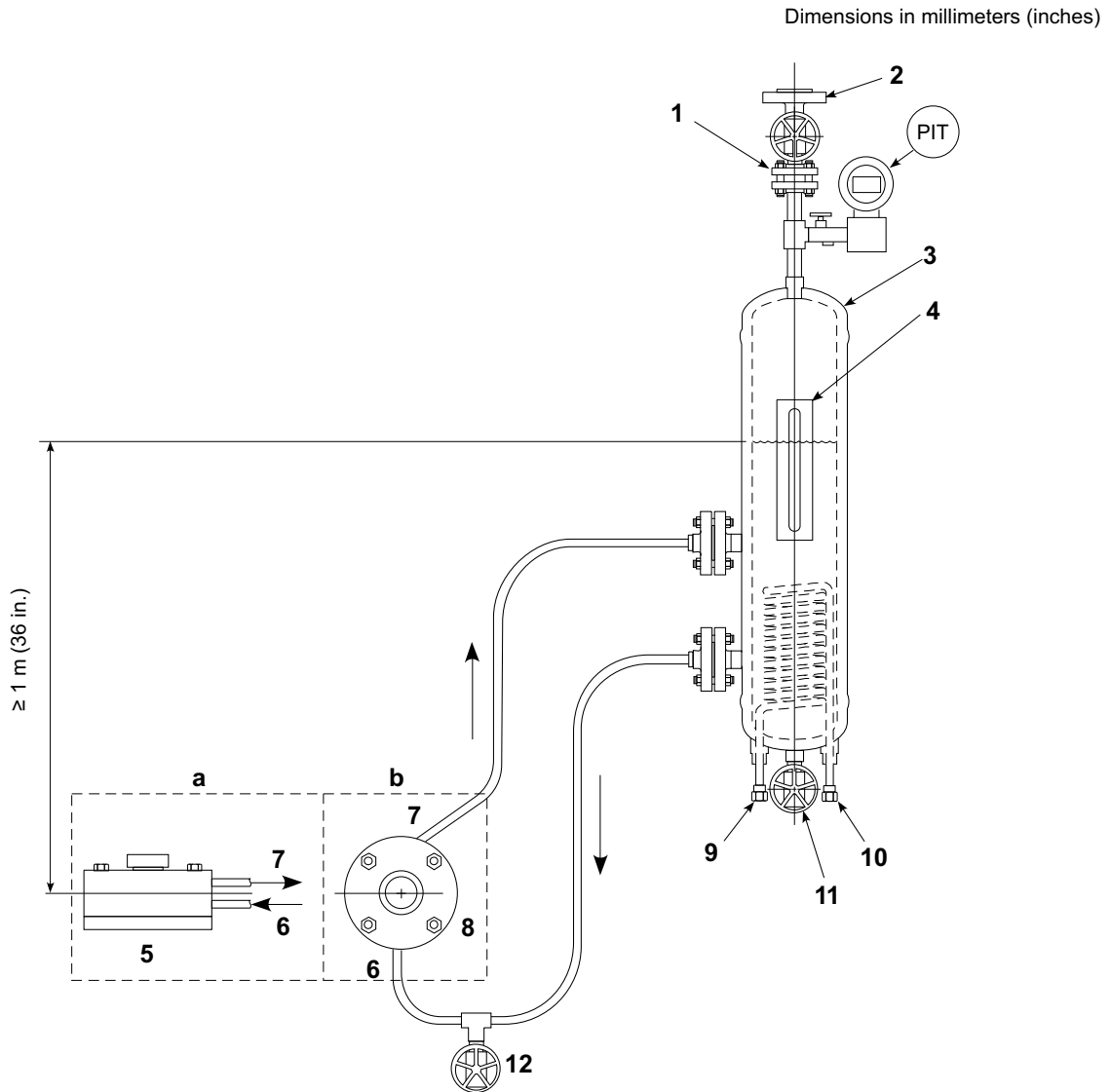

Key

- | | | | |
|---|-----------------|----|--------------------------------------|
| 1 | flanged orifice | 7 | to reservoir |
| 2 | vent | 8 | gland, horizontal |
| 3 | reservoir | 9 | cooling liquid inlet |
| 4 | level indicator | 10 | cooling liquid outlet |
| 5 | gland, vertical | 11 | reservoir barrier/buffer fluid drain |
| 6 | from reservoir | 12 | barrier/buffer fluid drain |

a For vertical applications.

b For horizontal applications.

Figure G.38—Typical Installation of a Barrier/Buffer Fluid Reservoir

The seal reservoir shall be located as close to the pump as possible while leaving sufficient room for operation and maintenance. It should not be located directly above the pump. Hot lines shall be insulated as necessary for safety.

For tubing, smooth, long radius bends shall be used. For piping, the number of 90° elbows shall be minimized, although 45° elbows may be used.

All lines shall slope up from the gland to the high point vent; the slope shall be 40 mm/m (0.5 in./ft).

Annex H
(informative)

Inspectors' Checklist for All Seals

Item	Subsection Reference	Date Inspected	Inspected by	Status
Gland connections marked	6.1.2.17			
Plugs and tagging	6.1.2.18			
Weld procedures approved	6.1.6.10.1			
Repair procedures approved	6.1.6.10.2			
Wrought material inspections	6.1.6.10.4			
Welded connections	6.1.6.10.5			
Impact test results	6.1.6.11.3			
Adequate clearance and safe access	8.1.3			
Piping, fabrication, examination, and inspection meet standards and weld procedures approved.	8.2.10 8.2.11			
Tags attached to coolers	8.3.2.1.4			
Orifice data	8.3.5.2			
Buffer/barrier-fluid reservoir tag	8.3.6.2.10			
Reservoir sizing criteria	8.3.6.2.5			
Relief valve list	9.8.1			
Compliance with inspector's checklist	10.1.7			
NDE inspection results	10.2.3			
Cleanliness inspection	10.2.3 j) 10.4.3 c)			
Hardness test results	10.2.3 k)			
Qualification test results	10.3.2.4			
Test certificate	10.3.2.4			
Certified hydrostatic test results	10.3.3.1			
Seal supplied air test tag	10.3.4.2			
Seal leakage acceptance criteria	10.3.2.3 I.4.10			
Site storage procedures	10.4.2			
Preparation for shipment	10.4.3			
Auxiliary piping connections tagged or marked	10.4.4			
Installation instructions	10.4.5			
Contract data	11.1.1 and Annex E			

Figure H.1—Inspectors' Checklist

Annex I (normative)

Seal Qualification Testing Protocol

I.1 General (Informative)

I.1.1 The detailed protocol for qualification testing of seals has been moved to this annex from the text sections of prior editions of this standard. This reorganization simplifies the standard for the majority of users while providing the necessary details required by seal manufacturers to accurately and consistently perform testing. This annex also provides a historical perspective on the qualification testing and the intent of the testing that has not been previously captured.

I.1.2 Seal manufacturers provide specialized products for many industries. Most of the designs available have a long history of proven success in the application for which the seal is designed. A relatively small subset of the total seal population is for the petroleum, petrochemical, and natural gas industries that are covered by this standard; therefore, it is normal to expect special services and applications to be outside its scope and associated qualification tests. Even within the petroleum, petrochemical, and natural gas industries there is a vast array of temperatures, pressures, and liquids sealed with mechanical seals. End users as well as manufacturers recognized the need to increase the design and testing focus of sealing products intended for petroleum, petrochemical, and natural gas industries to address the need for increased standardization, improved reliability, and lower leakage.

One of the many important features of the First Edition of API 682 in 1994 was the introduction of qualification testing of seals. API 682 compliant seals would meet the standard and be qualified if two sizes of a specific seal design and material were tested in one or more of the four qualification test fluids. At the time of the First Edition, there were no pass/fail criteria. Criteria for wear and leakage were added in the Second Edition (2002). The intent of qualification testing is to provide the end user with a high degree of confidence that the commercial seal product being offered will perform successfully in the intended service by virtue of passing tests on the appropriate test fluid for the representative pumped fluid and service condition as shown in Table I.2.

I.1.3 Users and manufacturers recognize that seals are designed for specific applications and a single design will not be suitable for all applications. Typically, users want less expensive seals for less arduous services and manufacturers will qualify those seals for only those services. For example, there is little need to qualify a high-temperature metal bellows seal with flexible graphite secondary seals for use in a cold water service. Likewise, simple cold water seals will not be used in high-temperature services and obviously would not pass the hot oil qualification test. At the same time, through continuous improvement efforts by all, numerous design variations—including materials, geometry, loading, and seal auxiliary support systems—are implemented, tested and qualified. The population of qualified seal designs, materials, and auxiliary components is substantial and increasing.

I.1.4 Manufacturers keep qualification test records of all complying seal designs and sizes and can provide them on request. The various seal configurations are shown in Figure 1; many of these have been newly introduced since API 682:1994 (First Edition). Many of the new configurations utilized seals that had been previously qualified; however, additional qualification testing parameters were required for the untested designs and components. For example, noncontacting seal face designs were introduced in API 682:2002 (Second Edition) and testing in a gas environment was required as part of the qualification tests for those products.

I.1.5 Table I.1 illustrates how qualification testing for different seal configurations has generally been organized by seal manufacturers. While category, size, face material, type, and flexible element orientation may vary, the basic seal configuration largely dictates the qualification test scope, procedure, and fluid. Because of the large number of possible combinations of these parameters (approximately 4000) it is unlikely that seal manufacturers have tested or will test all possible combinations in all possible qualification test fluids. Seal manufacturers often first focus their testing efforts on the defaults of this standard, their own most popular products and the most representative test conditions for specific service applications. Users should verify that the required seal qualification tests have been performed for their intended application. It is possible that the qualification test for a special design or a new product has not yet been conducted. If the required tests have not yet been conducted, the user and the manufacturer shall mutually agree on the necessary steps to qualify that commercially available product.

I.1.6 As an example, consider the seal configuration 2CW-CS from Table I.1. This is an Arrangement 2 seal cartridge fitted with a contacting, wet inner seal and dry-running containment seal as the outer seal. A manufacturer might make 2CW-CS using Type A, rotary flexible element components but another manufacturer might use Type A, stationary flexible element components. Other manufacturers might choose Type B, Type C, or even mix seal types. There are four face material pairs that might be considered for testing and any, or all, such pairs might be tested. Whatever is to be offered to the purchaser shall be tested. Examples of combinations include:

- Type A, carbon/SSiC, rotary flexible element;
- Type A, SSiC/SSiC, stationary flexible element;
- Type B, carbon/SSiC, stationary flexible element, etc.

Again, it is not required to test all possible combinations but the combination that is to be offered to the purchaser shall be tested.

I.1.7 It is also required to test two sizes within a range of balance diameters; for example, a manufacturer might choose to test 50 mm and 100 mm balance diameter seal cartridges.

If the manufacturer wishes to offer the 2CW-CS for service in a vaporizing liquid then the qualification tests shall be accomplished in propane as the process liquid, propane gas as the buffer gas and commercially available petroleum based diesel fuel as the buffer liquid.

The configuration 2CW-CS would first be tested according to I.4.1. In this test, the inner seal is subjected to a series of steady state and cyclic process simulations. Next, the containment seal is subjected to variations in buffer fluid conditions according to I.4.5. The combination of these tests is likely to take more than three hundred hours (300 h) to complete. On completing tests of both 50 mm and 100 mm balance diameter seal cartridges, that commercial product is qualified for vaporizing services. That commercial product is not qualified for, as an example, aqueous solutions because the representative test fluid for aqueous solutions is water. To qualify the commercial product for aqueous solutions, the entire seal sequences shall be repeated but using water as the test fluid.

Table I.1—Organization of Qualification Testing

Seal Design Parameters ^a						Test Parameters ^b									
Category	Seal Balance Diameter mm	Face Material Pair	Type	Flexible Element	Configuration	Scope	Procedure	Fluid							
1	38 to 75 >75 to <127	Carbon/SSiC Carbon/RBSiC SSiC/SSiC RBSiC/RBSiC	A B C	Rotary stationary	1CW-FX	Inner seal	Dynamic static and cyclic phase according to I.4.1 approx- imately 100 h	Water propane NaOH oil cold oil hot							
					1CW-FL ^c										
					2CW-CW ^c	Inner seal and arrangement									
					2CW-CS										
					2NC-CS										
					3CW-FB ^c	Arrangement									
					3CW-BB										
					3CW-FF										
					2 3	50 to 75 100 to 127			Carbon/SSiC Carbon/RBSiC SSiC/SSiC RBSiC/RBSiC	A B C	Rotary stationary	3NC-BB ^{c, e}	Only containment seal	Dynamic and static phase according to I.4.5 approx. 200 h	Water, oil or diesel ^f and nitrogen, steam, or propane according to Table I.3
												3NC-FB ^e			
3NC-FF ^e															
2CW-CS ^d	Arrangement	Variable bar- rier gas pressure according to I.4.6 approx. 1 h	Nitrogen												
2NC-CS ^d															
3NC-BB ^{c e}															

^a A test seal cartridge is specified by the parameters in this column and the representative materials and geometry of its core seal components. In dual seals combinations of face material pairs, types and flexible element positions are possible.

^b For a specific service, a seal vendor's commercial product only needs to be tested in the representative test fluid.

^c Default.

^d 2CW-CS and 2NC-CS shall be tested as inner seal, arrangement and containment seal in accordance with I.4.1 and I.4.5.

^e 3NC-BB, 3NC-FB, and 3NC-FF shall be tested as arrangement in accordance with I.4.1 and I.4.6.

^f Commercially available petroleum based diesel fuel.

I.2 Hierarchy and Attributes of Sealing Systems

The specification and selection of a sealing system is not possible without an understanding of the terminology, attributes and hierarchy used to describe it. Although there are many variations and much overlapping within the industry, this standard has adopted the terms and definitions of Section 3 to describe the attributes of a sealing system. In addition, the hierarchy of a typical sealing system is illustrated below. The numbers prior to each attribute indicate the level within the hierarchy.

The references shown below are for general reference only and are not an all-inclusive index.

1. Seal cartridge

2. Core seal components

- 3. Seal ring assembly
 - 4. Seal ring shape (see 6.1.5)
 - 4. Seal ring material (see 6.1.6.2.2)
 - 4. Seal ring drive mechanism(s)
 - 4. Secondary seal material and hardness (see 6.1.6.5)
 - 4. Spring(s)
 - 5. Single spring
 - 5. Multiple springs
 - 5. Metal bellows
 - 4. Spring force control mechanism
- 3. Mating ring assembly
 - 4. Mating ring shape (see 6.1.4)
 - 4. Mating ring material and hardness (see 6.1.6.2.2)
 - 4. Mating ring drive mechanism(s) (see 6.1.4.1)
 - 4. Secondary seal material (see 6.1.6.5)

2. Adaptive hardware

- 3. Sleeve (see 6.1.3)
 - 4. Sleeve drive mechanism
 - 5. Drive collar (see 6.1.1.4)
 - 5. Set screws (see 6.1.3.12)
 - 5. Alternative drive mechanisms
- 3. Gland plate (see 6.1.2)
 - 4. Connection orientation (see Table 2)
 - 4. Flush geometry
 - 5. Single point flush
 - 5. Distributed flush
- 3. Positive circulation device
 - 4. None
 - 4. Internal
 - 4. External pump
 - 4. External flush

2. Seal category (see 4.1.2)

- 3. Category 1
- 3. Category 2
- 3. Category 3

2. Seal type (see 4.1.3)

- 3. Type A
- 3. Type B
- 3. Type C

2. Seal configuration (see Figure 1)

- 3. Seal arrangement (see 4.1.4)
 - 4. Arrangement 1 (see 7.1)
 - 4. Arrangement 2 (see 7.2)
 - 4. Arrangement 3 (see 7.3)

- 3. Rotating component (see 6.1.1.2, 6.1.1.3, 6.1.1.5)
 - 4. Seal ring rotates
 - 4. Mating ring rotates
- 3. Sealing interface (see 4.1.4)
 - 4. Contacting wet
 - 4. Contacting dry
 - 4. Noncontacting wet
 - 4. Noncontacting dry
- 3. Seal ring orientation (see Figure 1 and 4.1.5)
 - 4. Single seal: not applicable
 - 4. Dual seal: back-to-back
 - 4. Dual seal: face-to-face
 - 4. Dual seal: face-to-back
- 3. Containment device
 - 4. Fixed bushing (see 7.1.2.1)
 - 4. Floating carbon bushing (see 7.1.2.1)
 - 4. Segmented, floating carbon bushing (see 7.1.2.1)
 - 4. Containment seal (see 7.2.4, 7.2.5)
- 1. **Seal chamber** (see 6.1.2)
 - 2. **Traditional**
 - 2. **Externally mounted**
 - 2. **Internally mounted**
- 1. **Accessories** (see Section 8)
 - 2. **Interconnecting piping for seal auxiliary systems** (see 8.2)
 - 2. **Seal auxiliary system** (see 8.3)
 - 3. Seal auxiliary system components

I.3 Scope of Test

I.3.1 Qualification tests shall be conducted using the core seal components, adaptive hardware, seal types, and seal configurations as proposed for commercially available seals. For dual seals, qualification testing shall be done using an internal circulation device only and this test with the internal circulation device shall serve as qualification for external circulation devices.

I.3.2 Commercially available products shall be tested by configuration and in accordance with I.3.6, I.3.7, I.3.8, and I.3.9. However, the following attributes, features or components shall not be considered as part of the test:

- a) throttle bushings (whether fixed, floating, or multiple);
- b) dynamic secondary seal material except for durometer, see 6.1.6.5 and I.3.9. See Annex B for tutorial discussion of elastomer properties;
- c) static secondary seal material.

I.3.3 Seal types are qualified only for the configuration used during that test; however, a configuration may have mixed seal types. The requirements for qualification may be transferred among combinations of seal types and configurations that share the same adaptive hardware provided each seal type has been tested in that configuration.

NOTE As an example, if configuration 3CW-BB has been qualified in propane using Type A seals as both the inner and outer seal and a similar 3CW-BB has also been qualified in propane using Type B seals as both the inner and outer seal then those seal types may be mixed in that configuration (3CW-BB) for light hydrocarbon services. That is, the configuration is also qualified with Type A as the inner seal and Type B as the outer seal as well as Type B as the inner seal and Type A as the outer seal. For purposes of transferring qualification, dry-running containment seals may be considered to be a seal type.

I.3.4 Core seal components are qualified only for the adaptive hardware and configuration used during that test.

NOTE Adaptive hardware of the commercially available product should be essentially identical to the qualified seal in terms of functionality and internal geometry. However, the manufacturer's commercially available product may deviate from the test design to fit into a specific seal chamber or to realize enhanced performance. The manufacturer should be able to adequately demonstrate the enhanced performance of a modified design.

I.3.5 The requirements to become a qualified seal may be transferred across categories for commercial products that share the following features and attributes:

- a) core seal components;
- b) adaptive hardware;
- c) seal type;
- d) configuration.

Category 3 qualification may be transferred to Category 2 or Category 1. Category 2 qualification may be transferred to Category 1.

NOTE This potentially reduces the number of tests and provides incentives for reducing inventory of spare parts; however, Category 3 seals can be qualified only through specific testing.

I.3.6 To be qualified for use in a particular pumped fluid and service condition, a manufacturer's commercial product shall be successfully tested using the appropriate qualification test fluid as given in Table I.2. A qualified seal, for the service represented by the qualification test fluid, requires the product shall meet all the criteria of 10.3.2.3.

NOTE 1 A seal manufacturer's commercial product need be tested only in the representative qualification test fluid to its required service. It is not necessary to test a commercial product in all qualification test fluids.

NOTE 2 The qualification test fluids were selected to model the behavior of the fluids described in the recommended seal selection procedure (Annex A). The properties of the qualification test fluids are representative of the properties of the pumped fluid and service conditions (for example, viscosity, corrosiveness, crystallization, vapor pressure, hydrocarbon, or nonhydrocarbon). The qualification test fluids selected were considered to be readily available and safe for testing in a laboratory environment.

I.3.7 The nominal balance diameters of the seals to be tested shall be as follows:

- for Category 1 seals the nominal balance diameter shall be 38 mm to 75 mm (1.5 in. to 3 in.) and larger than 75 mm to 127 mm (3 in. to 5 in.);
- for Category 2 and 3 seals the nominal balance diameter shall be 50 mm to 75 mm (2 in. to 3 in.) and 100 mm to 127 mm (4 in. to 5 in.);
- for seals outside the scope of this standard, additional qualification testing should be considered.

NOTE Many seal applications are covered by this standard. The testing of these sizes is considered representative of the range of sizes identified. The performance of sizes between the test sizes is considered to be similar to the test sizes.

Table I.2—Qualification Test Fluid and Pumped Fluid Selection Chart

Pumped Fluid and Service Conditions	Qualification Test Fluid			
	Water	Propane	NaOH (20 %)	Mineral Oil
Nonhydrocarbons				
Water	Test #1			
Sour water	Test #1			
Caustic			Test #3	
Acid	Test #1			
Nonflashing hydrocarbons				
–40 °C to <–5 °C (–40 °F to <23 °F)		Test #2		
–5 °C to <176 °C (23 °F to <348.8 °F)				Test #4
176 °C to <260 °C (348.8 °F to <500 °F)				Test #5
260 °C to 400 °C (500 °F to 750 °F)				Test #5
Flashing hydrocarbons				
–40 °C to <–5 °C (–40 °F to <23 °F)		Test #2		
–5 °C to <176 °C (23 °F to <348.8 °F)		Test #2		
176 °C to <260 °C (348.8 °F to <500 °F)				Test #5
260 °C to 400 °C (500 °F to 750 °F)				Test #5
NOTE The temperature ranges refer to the temperature ranges in Annex A, Sheets 4 and 5. The test numbers refer to the test numbers defined by Table I.3.				

I.3.8 After one face material pair (a specific combination of seal ring material and mating ring material including vendor, grade, surface finish and profile) has been successfully qualified according to I.3, additional face material pairs may be qualified for the same service represented by the qualification test fluid used in that test as follows.

- Using the same seal ring material as tested in I.3.8, additional mating ring materials (vendor, grade, surface finish, and profile) may be qualified for use with that same seal ring material by testing only the larger test size for that category in the qualification test fluid.
- Using the same mating ring material as tested in I.3.8, additional seal ring materials (vendor, grade, surface finish, and profile) may be may be qualified for use with that same mating ring material by testing only the larger test size for that category in the representative qualification test fluid.

NOTE This reduces the number of tests and promotes testing of additional face materials.

I.3.9 After one secondary seal elastomer material (vendor, grade, and durometer) has been successfully qualified according to I.3, additional secondary seal elastomeric materials are qualified for the same service represented by the qualification test fluid used in that test as follows:

- shall comply with 6.1.6.5;
- shall be the same nominal durometer hardness as used during previous qualification testing within ± 5 points.

NOTE This increases the number of approved secondary seal elastomeric materials without additional testing.

I.3.10 Each qualification test for each qualification test fluid shall consist of the three following phases (see Figure I.1 to Figure I.5):

- the dynamic phase shall be tested at constant temperature, pressure, and speed (base point);
- the static phase shall be tested at 0 r/min using the same temperature and pressure as the dynamic phase;
- the cyclic phase shall be tested at varying temperatures and pressures, including start-ups and shut-downs. For flashing hydrocarbons, the cyclic test phase shall include excursions into vapor and back to liquid (flash and recovery).

NOTE These phases were selected to qualify the seal type for the operating ranges (temperatures and pressures) defined for the pumped fluid and process conditions shown in Table I.2. Figure I.1 to Figure I.5 show a graphical representation of the test operating parameters for all three phases and each qualification test fluid. The test phases were selected to model actual pump operating conditions such as normal running, upset, standby, and start-up/shutdown.

I.3.11 For Arrangement 1 seals, demonstrate the performance of the seal in accordance with I.4.

I.3.12 For Arrangement 2 seals using liquid buffer fluids (2CW-CW):

- demonstrate the performance of the inner seal without the outer seal and the buffer fluid in accordance with I.4;
- demonstrate the performance of the arrangement with the outer seal and the buffer fluid in accordance with I.4.

I.3.13 For Arrangement 2 seals using a containment seal, with or without a buffer gas purge (2CW-CS, 2NC-CS) during normal service.

- a) For arrangements using contacting inner seals (2CW-CS) only, demonstrate the performance of the inner seal without the outer seal in accordance with I.4. Tests numbered 1, 2, 3, and 4 in Table I.3 are to be conducted without a gas purge for this phase of testing; test number 5 shall be conducted with a gas purge.
- b) Demonstrate the performance of the arrangement with the inner seal and outer seal in accordance with I.4. Tests numbered 1, 2, 3, and 4 in Table I.3 are to be conducted without a gas purge for this phase of testing; test number 5 shall be conducted with a gas purge.
- c) After completion of Item b), demonstrate the performance of the containment seal in accordance with I.4.5.

NOTE Test number 5 is for hot services for which a gas purge/quench is frequently used.

I.3.14 For Arrangement 3 seals using liquid barrier fluids:**I.3.14.1** For configuration 3CW-FB only:

- a) demonstrate the performance of the inner seal without the outer seal and the barrier fluid in accordance with I.4;
- b) demonstrate the performance of the arrangement with the outer seal and the barrier fluid in accordance with I.4.

I.3.14.2 For configurations 3CW-FF, 3CW-BB only:

- a) demonstrate the performance of the arrangement with the outer seal and the barrier fluid in accordance with I.4;
- b) demonstrate the performance of the arrangement with the outer seal and the barrier fluid in accordance with I.4.7.

NOTE Arrangement 3 seals are tested to simulate an unusual combination of pump operating conditions or an upset or failure condition that can realistically occur during operation.

Different configurations can offer varying operational benefits. The FB configuration has a greater tolerance to operation with a loss of barrier liquid or pressure but may have a limited performance with higher pressure differentials across the inner seal than FF or BB configurations. The FF and BB configurations, however, have greater potential to manage an unusual range of chamber conditions which produce high inner seal pressure differentials but are less tolerant to a loss of barrier liquid and pressure. The qualification tests have been devised to recognize the different configuration benefits.

There are two potential conditions which could occur.

Condition 1 Loss of barrier fluid and pressure is simulated by I.3.14.1 a). This test is applied to the FB configuration but not to the BB or FF orientation which are less tolerant to this condition. The qualification test plan for BB and FF configurations in I.4.7 includes a much shorter dynamic period of barrier fluid pressure loss but with an extended static check to ensure containment is still maintained.

Condition 2 Loss of pump pressure is simulated by I.4.4 b) and I.4.7 a). This condition simulates operation of the pump when there are pump suction upsets or wide swings in suction pressure. It would also simulate operation of the pump when the barrier fluid is fully pressurized prior to pressurizing the pump. The longer test in I.4.7a applies only to FF and BB configurations to test their greater tolerance to this condition whereas FB configurations are tested for the shorter period in the cyclic phase of I.4.4.

I.3.15 For Arrangement 3 seals using a gas barrier (3NC-BB, 3NC-FF, 3NC-FB):

- a) the barrier gas used during qualification testing shall be nitrogen;
- b) demonstrate the performance of the arrangement in accordance with I.4;
- c) demonstrate the performance of the arrangement at variable barrier-gas pressures in accordance with I.4.6.

I.4 Test Procedure

I.4.1 The test sequence shall be in accordance with I.4.2 to I.4.12 and as shown in Figure I.6. The test shall consist of dynamic, static, and cyclic phases. The three test phases shall be run consecutively, without disassembly of the seal.

I.4.2 The dynamic phase of the qualification test shall be operated continuously for a minimum of 100 h at 3600 r/min under the base-point conditions, as specified in Table I.3.

I.4.3 The static phase of the qualification test shall run for a minimum of 4 h at 0 r/min (shutdown) under the base-point conditions, as specified in Table I.3. No rotation of the shaft is allowed during the static test.

I.4.4 The cyclic phase of the qualification test shall be at the temperatures and pressures specified in Table I.3 and performed as follows:

- a) operate the seal at base-point pressure and temperature conditions and at 3600 r/min until equilibrium has been established;
- b) drop the pressure to cause all fluid in the seal chamber to vaporize or drop to a gauge pressure of 0 MPa (0 bar) (0 psi) for nonflashing fluids. Reestablish base pressure;
- c) drop the fluid temperature in the seal chamber to the minimum cyclic test temperature specified in Table I.3. Reestablish base-point conditions;
- d) raise the fluid temperature in the seal chamber to the maximum cyclic test temperature specified in Table I.3. Reestablish the base-point conditions. For the mineral oil tests, after the base condition is reached, raise the fluid pressure in the seal chamber to the maximum cyclic test pressure specified in Table I.3. Reestablish the base-point conditions;
- e) turn off the seal flush for 1 min, if applicable;
- f) shut down the test (0 r/min) for at least 10 min;
- g) establish base-point conditions and operate at 3600 r/min;
- h) repeat Steps b) to g), three additional times;
- i) repeat Steps b) to e);
- j) reestablish flush and allow test seal to reach equilibrium conditions (including emissions for hydrocarbons) at the base point; and
- k) shut down the test (0 r/min). Maintain base-point conditions for at least 10 min.

I.4.5 In addition to the requirements of I.3.13, Arrangement 2 dry-running containment seals shall be tested, without disassembly, with the inner seal at the base-point conditions, as follows (see Figure I.7).

- a) Continuously operate a gas-pressured phase at 3600 r/min in the buffer gas listed in Table I.3 at a gauge pressure of 0.07 MPa (0.7 bar) (10 psi) and a supply temperature within the range of the cyclic temperature range listed in Table I.3. For tests numbers 2 and 5 in Table I.3, the duration of this phase shall be one hundred hours (100 h). For tests numbers 1, 3, and 4 in Table I.3, the duration of this phase shall be twenty-four hours (24 h) provided the containment seal design and materials have been previously qualified in test numbers 2; otherwise, the duration shall be one hundred hours (100 h).

NOTE Tests 1, 2, 3, and 4 are at moderate temperatures and the containment seal buffer gas is nitrogen.

- b) On completion of Item a), pressurize the seal with nitrogen or air and test according to the air test procedure of 10.3.5. The pressure decay may exceed the requirements of 10.3.5 but shall be recorded every minute, and no rotation of the shaft is permitted during this test.

Table I.3—Seal Qualification Test Parameters

Qualification Test Conditions											
Qualification Test Number and Fluid		Barrier/Buffer Qualification Test Fluids for Dual Seals		Base Point				Cyclic Ranges			
				Dynamic and Static							
		Liquid	Gas	Absolute Pressure ^a		Temperature ^b		Absolute Pressure ^a		Temperature ^b	
				MPa	(psi)	°C	(°F)	MPa	(psi)	°C	(°F)
1	Water	Glycol/water	Nitrogen	0.4	58	80	176	0.1 to 0.4	15 to 58	20 to 80	68 to 176
2	Propane	Diesel ^d	Buffer: propane Barrier: nitrogen	1.8	261	30	86	1.1 to 1.8	160 to 261	30	86
3	20 % NaOH	Glycol/water	Nitrogen	0.8	116	20	68	0.1 to 0.8	15 to 116	20 to 80	68 to 176
4	Mineral oil -5 °C (23 °F) to <176 °C (348.8 °F) applications	Diesel ^d	Nitrogen	0.8	116	20	68	Type A, Category 2, 3		20 to 90	68 to 194
								0.1 to 3.5	15 to 508		
								All others			
								0.1 to 0.7	15 to 246		
5	Mineral oil 176 °C (348.8 °F) to 400 °C (750 °F) applications	Mineral oil	Steam or nitrogen	0.8	116	260	500	Type A, Category 2, 3		150 to 260	302 to 500
								0.1 to 3.5	15 to 508		
								All others			
								0.1 to 1.7	15 to 246		

NOTE The test numbers are defined by Table I.3 and are referenced by Table I.2.

^a Pressure tolerance range ±2 %.

^b Temperature tolerance range is ±2.5 °C (4.5 °F).

^c Cyclic pressure range for Category 1 seal and single-ply metal bellows seals in Categories 1, 2, and 3.

^d Commercially available petroleum-based diesel fuel.

- c) On completion of Item b), fill the containment seal chamber area with the buffer liquid listed in Table I.3 at a temperature within the range of the cyclic temperature range listed in Table I.3 and pressurize to a gauge pressure of 0.28 MPa (2.8 bar) (40 psi). Restart, maintain pressure, and operate at 3600 r/min. Record the leakage rate. For tests numbers 2 and 5 in Table I.3, the duration of this phase shall be 100 h. For tests numbers 1, 3, and 4 in Table I.3, the duration of this phase shall be 24 h provided the containment seal design and materials have been previously qualified in test number 2; otherwise, the duration shall be 100 h.
- d) On completion of Item c), test the seal statically in with the buffer liquid listed in Table I.3 for at least 4 h at 0 r/min (shutdown) at a gauge pressure of 1.7 MPa (17 bar) (246 psi); no rotation of the shaft is permitted during the static test, and the leakage rate shall be reported.

NOTE 1 Subsection I.4.5 a) of this test is considered to be normal operation, the remainder of the test is considered to be upset condition.

NOTE 2 During the qualification test of the Arrangement 2 seal, the containment seal runs at a low pressure and in the vapor or liquid leaked by the inner seal. The gauge pressure of 0.28 MPa (2.8 bar) (40 psi) is referenced to an assumed maximum flare header pressure.

I.4.6 For Arrangement 3 seals using a gas barrier, the performance of the arrangement at variable barrier-gas pressure shall be demonstrated as follows (see Figure I.8):

- a) hold the barrier gas pressure at a gauge pressure of zero for at least 1 h (this is a static test);
- b) restore barrier gas pressure, restart, and run until equilibrium is established; record any process leakage as well as barrier gas consumption;
- c) while the seal is running, isolate the barrier gas supply immediately adjacent to the seal for a 1-min period;

NOTE The purpose of this is to simulate field conditions of varying buffer gas supply.

- d) restore barrier gas pressure, run until equilibrium is established, and record any process leakage as well as barrier-fluid consumption;
- e) shut down the seal (0 r/min). With the gas control panel blocked in, maintain base-point conditions for the process (inner) seal for 10 min and record any pressure rise in the barrier system.

NOTE This section continues the testing of the Arrangement 3 gas-pressurized seals after I.4.4. It provides a test of the ability to survive upsets and startup problems.

I.4.7 For Arrangement 3 seal configurations 3CW-FF, 3CW-BB using a liquid barrier, in addition to the requirements of I.4, the performance of the arrangement at variable barrier liquid pressure shall be demonstrated as follows:

- a) test for 100 h with the barrier fluid pressure higher than the base point pressure (see 8.3.6.1.10) but with no fluid and no pressure in the seal chamber. This is a steady state test;
- b) while the seal is running, flood the seal chamber with test fluid at base point conditions;
- c) allow seals to reach equilibrium conditions;
- d) reduce barrier fluid pressure to zero and continue operation for one minute with full base point pressure reversal on inner seal and zero pressure on outer seal;

- e) repressurize test fluid to base point conditions and allow seals to reach equilibrium;
- f) stop rotation;
- g) depressurize and drain the barrier fluid. Allow the inner seal to statically seal full base point pressure for 4 h.

I.4.8 Measurements shall be recorded on forms requesting at least the data presented in Annex I.

I.4.9 The temperature and pressure measurements are values taken to be representative of the majority of the seal chamber volume of fluid.

NOTE The seal chamber fluid temperature that is measured is an average between inlet and outlet temperatures.

I.4.10 Leakage concentration of volatile organic compound (VOC) qualification test fluids shall be measured with an organic vapor analyzer based on Appendix A of Title 40, Part 60 of the U.S. *Code of Federal Regulations*, or equivalent. The results of the measurements shall be recorded at the points shown in Figure I.6, Figure I.7, and Figure I.8 as a minimum requirement.

NOTE Site measurements of VOC emissions are undertaken using EPA Method 21, which is a manual method intended to identify sources giving rise to emissions of more than 1000 ppm. The measurements described in I.4.10 are intended to predict the on-site results using EPA Method 21 from the qualification test results.

I.4.11 Instrumentation used to measure leakage concentration of VOCs shall be capable of identifying:

- a) the maximum emission concentration from the seal at the most likely leak point. The instrument shall sample at a maximum of 1 cm from the maximum emission source;
- b) the local ambient VOC concentration within a 1 m to 2 m radius from the probable source of a leak. This may involve a 360° sweep of the installation.

NOTE The requirements of I.4.11 are essentially the same as EPA Method 21; however, EPA Method 21 is a manual method for measuring leakage concentration whereas qualification testing may involve seal test rigs and automated data acquisition.

I.4.12 All gauge ranges shall preferably be selected so that the normal operating point is at the middle of the gauge's range.

I.4.13 Instruments and methods of measurement shall be in accordance with ASME PTC 8.2.

I.4.14 Seal-face wear shall be computed based on the average change in length of the faces as measured before and after testing. Measurements shall be taken at four places approximately equally spaced around the circumference of the seal faces.

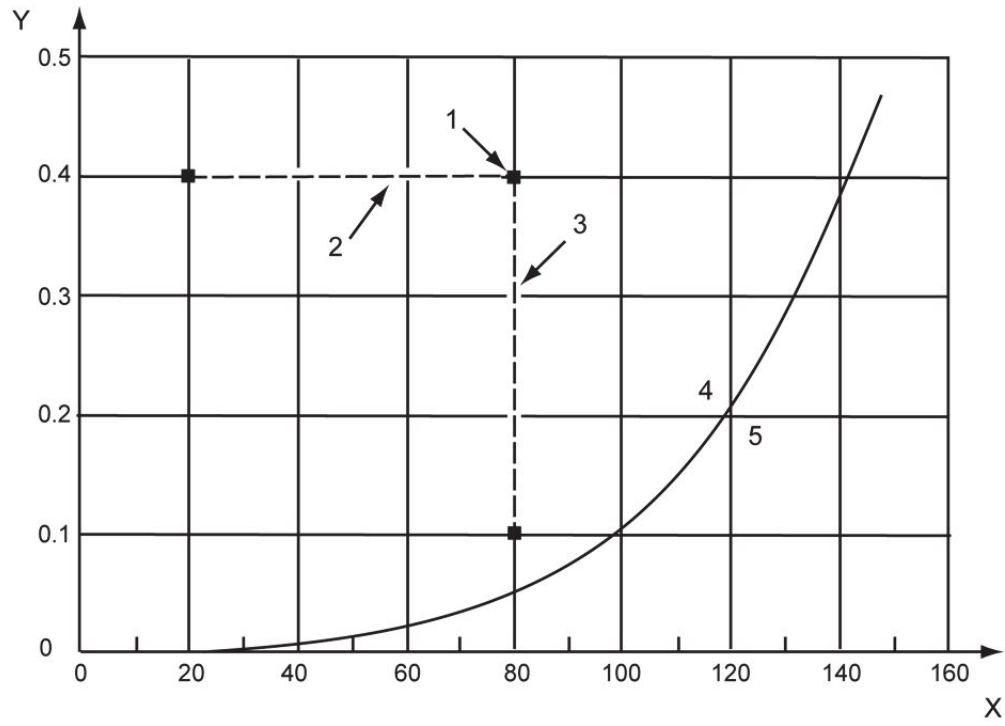

Key

- X temperature, °C
- Y absolute pressure, MPa
- 1 base-point conditions
- 2 temperature cycle
- 3 pressure cycle
- 4 liquid phase
- 5 vapor phase

Figure I.1—Water Test Parameters

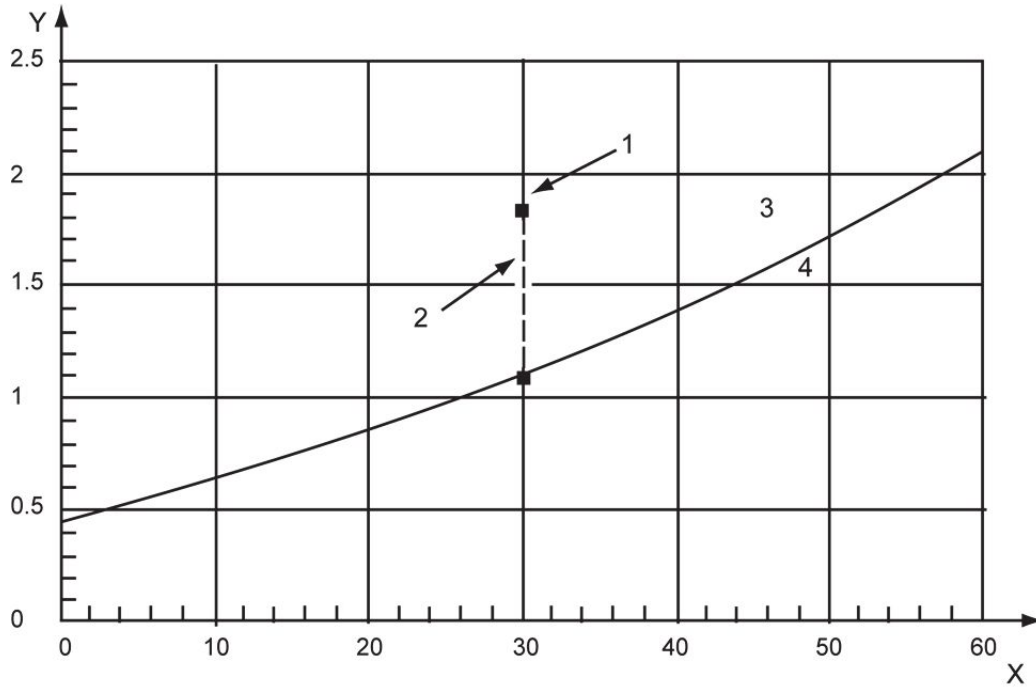
**Key**

- X temperature, °C
- Y absolute pressure, MPa
- 1 base-point conditions
- 2 pressure cycle
- 3 liquid phase
- 4 vapor phase

Figure I.2—Propane Test Parameters

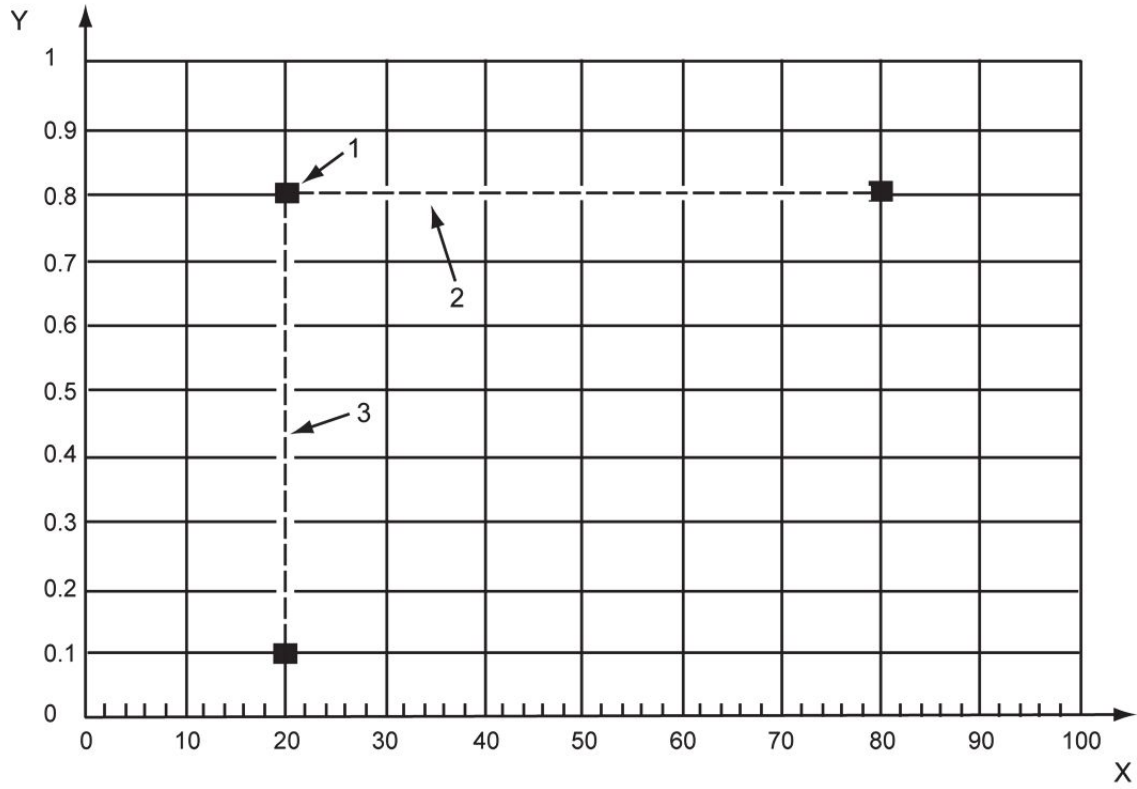

Key

- X temperature, °C
- Y absolute pressure, MPa
- 1 base-point conditions
- 2 temperature cycle
- 3 pressure cycle

Figure I.3—Caustic (NaOH) Test Parameters

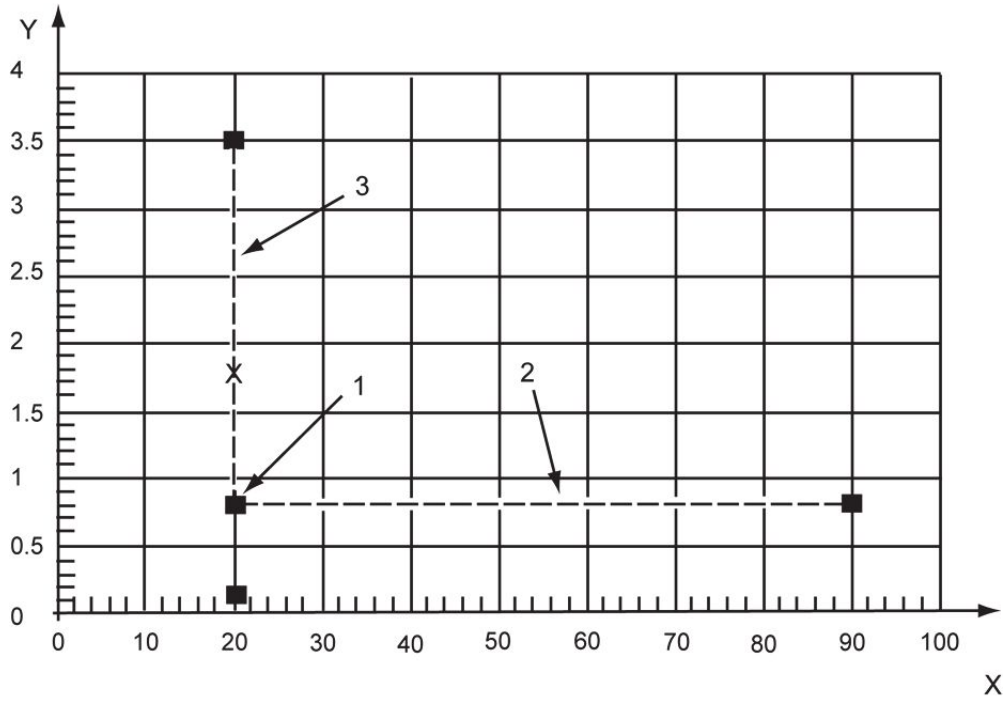
**Key**

- X temperature, °C
- Y absolute pressure, MPa
- 1 base-point conditions
- 2 temperature cycle
- 3 pressure cycle
- * limit of pressure cycle for Category 1 seals and single ply metal bellows seals in Categories 1, 2, and 3

**Figure I.4—Mineral Oil Test Parameters for Applications Between $-5\text{ }^{\circ}\text{C}$ and $176\text{ }^{\circ}\text{C}$
($23\text{ }^{\circ}\text{F}$ and $348.8\text{ }^{\circ}\text{F}$)**

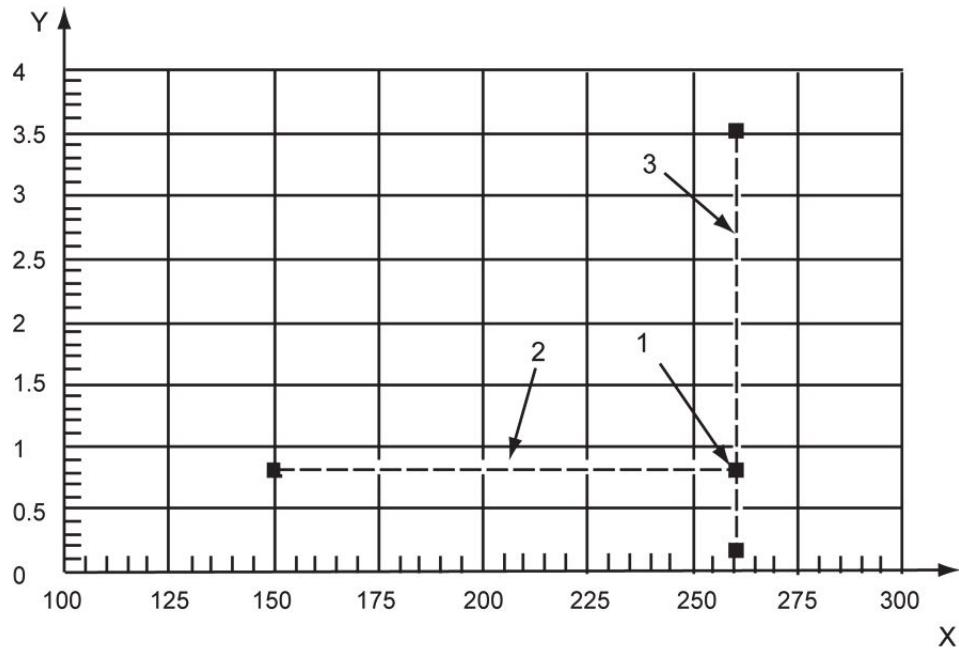
**Key**

- X temperature, °C
- Y absolute pressure, MPa

- 1 base-point conditions
- 2 temperature cycle
- 3 pressure cycle

**Figure I.5—Mineral Oil Test Parameters for Applications Between 176 °C and 400 °C
(348.8 °F and 750 °F)**

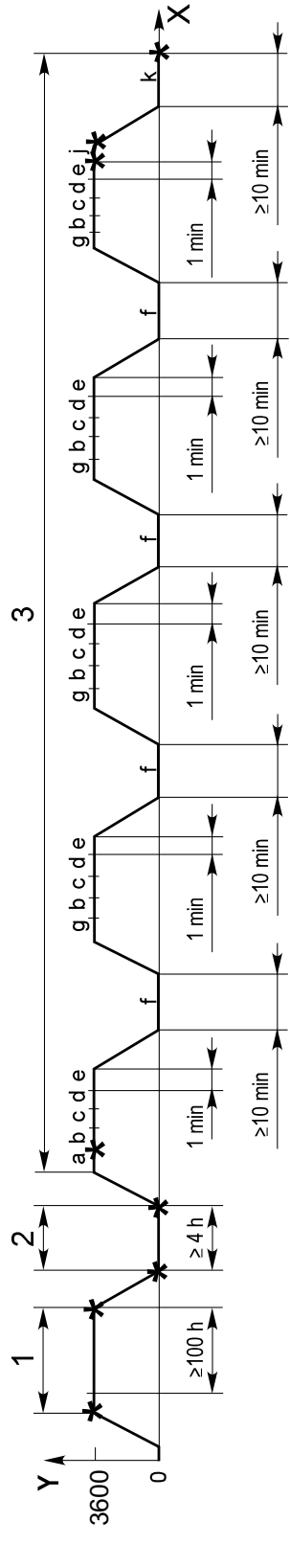

Key

- X time
- Y speed, r/min
- 1 dynamic test phase
- 2 static test phase
- 3 cyclic test phase

* indicates the timing that measurements are to be taken and recorded on the qualification test results from Figure I.9

NOTE The points a, b, c, d, e, f, g, j, and k relate to the steps in I.4.4.

Figure I.6—Seal Manufacturer Qualification Test Procedure

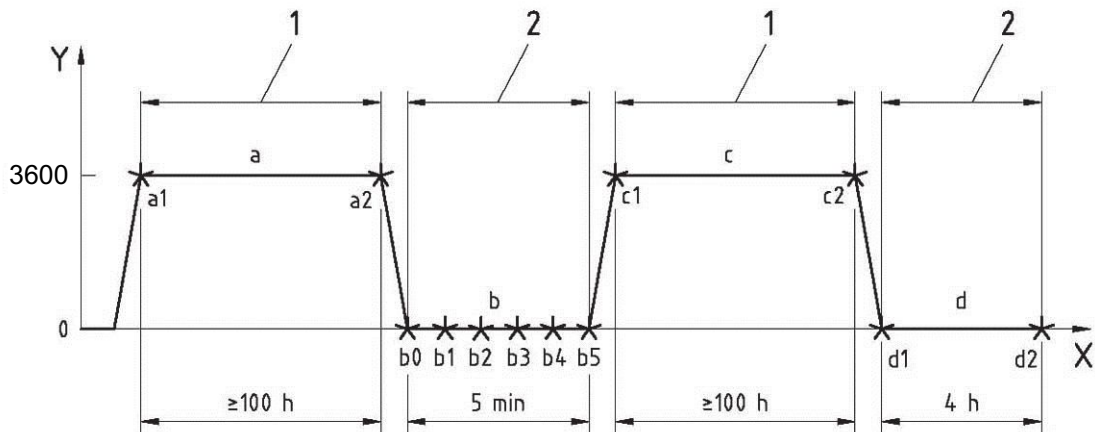

Key

- X time
 Y speed, r/min
 1 dynamic test phase
 2 static test phase

NOTE 1 Test cycle refers to I.4.5.

NOTE 2 Asterisks (★) indicate the timing and data-point designations for measurements that are taken in accordance with I.4.5 and Figure I.10.

- a A gauge pressure of 0.07 MPa (0.7 bar) (10 psi) of the buffer gas listed in Table I.3.
 b A gauge pressure of 0.17 MPa (1.7 bar) (25 psi) nitrogen.
 c A gauge pressure of 0.28 MPa (2.8 bar) (40 psi) of the buffer liquid listed in Table I.3.
 d A gauge pressure of 1.7 MPa (17 bar) (250 psi) of the buffer liquid listed in Table I.3.

Figure I.7—Seal Manufacturer Qualification Test Procedure for Containment Seals

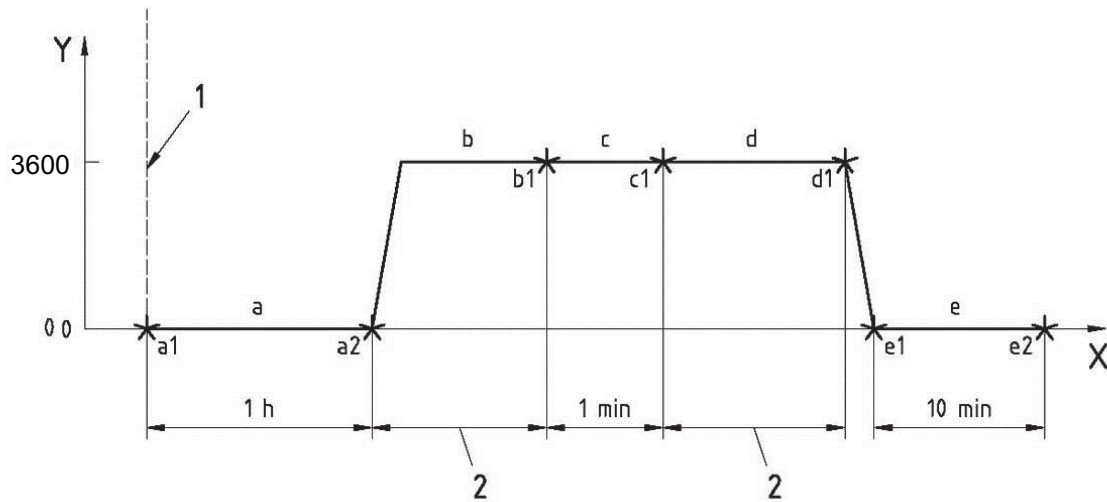
**Key**

X time

Y speed, r/min

1 commences at end point of Figure I.6

2 equilibrium

a Barrier at a gauge pressure of 0 MPa (0 bar) (0 psi), inner seal at base point test pressure.

b Barrier at normal barrier gas pressure, inner seal at base point test pressure.

c Isolate barrier pressure from supply pressure, inner seal at base point test pressure.

d Barrier at normal barrier gas pressure, inner seal at base point test pressure.

e Barrier blocked in, inner seal at base point test pressure.

NOTE 1 Test cycle refers to I.4.6.

NOTE 2 An asterisk (★) indicates the timing and data-point designations for measurements that are taken in accordance with I.4.6 and I.10.

Figure I.8—Seal Manufacturer Qualification Test Procedure for Gas Barrier Seals

Mechanical Seal Qualification Test Form

1CW, 2CW-CW, 3CW-FB, 3CW-FF and 3CW-BB

Date: _____

Revision: _____

Manufacturer _____ Seal type/model _____
 Seal type A _____ B _____ C _____ ES _____
 Material of construction Rotating face _____ Stationary face _____
 Static secondary seals _____ Metal hardware _____
 Dynamic secondary seals _____ Durometer _____
 Seal size _____ Seal code _____ Piping Plan _____ Shaft speed _____
 Pumped fluid (Table I.2) Nonhydrocarbon (water, caustic, acid) _____ Nonflashing hydrocarbon _____ Flashing hydrocarbon _____
 Shaft runout (Figure 19) _____ Sleeve runout (Figure 19) _____ Seal chamber concentricity (Figure 12) _____ Seal chamber face runout (Figure 14) _____
 Test fluid _____ Base-point temperature °C (°F) _____ / _____ Base-point pressure MPa (bar) (psi) _____ / _____ / _____
 Relative density (SG) _____ Vapor pressure _____ Solids _____ Particle size _____ *Dual Seals

DYNAMIC TEST 100 h minimum			Pressure MPa (bar)(psi)	Process temp. °C (°F)	Flush temp. IN °C (°F)	Flush temp. OUT °C (°F)	Flush flow rate m ³ /h (U.S. gal/min)	Seal chamber temp. °C (°F)	Barrier fluid press. MPa (bar) (psi)	Barrier fluid temp. IN °C (°F)	Barrier fluid temp. OUT °C (°F)	Power consump- tion kW (hp)	Hydrocarbon leakage g/day	Nonhydrocarbon leakage (cm ³ /min)	Circulating device m ³ /h (U.S. gal/min)
Date	Time Start	Stop													
STATIC TEST 4 h minimum															
CYCLIC TEST 5 cycles minimum															

Figure I.9—Mechanical Seal Qualification Test Form (1CW, 2CW-CW, 3CW-FB, 3CW-FF, and 3CW-BB)

Mechanical Seal Qualification Test Form

2CW-CS, 2NC-CS, 3NC-FF, 3NC-BB, 3NC-FB

Manufacturer						Seal type/model					
Arrangement	2CW-CS _____	2NC-CS _____	3NC-FF _____	3NC-BB _____	3NC-FB _____						
Material of construction	Rotating face _____					Stationary face _____					
	Static secondary seals _____					Metal hardware _____					
	Dynamic secondary seals _____					Durometer _____					
Pumped fluid	Nonhydrocarbon (water, caustic, acid) _____		Nonflashing hydrocarbon _____		Flashing hydrocarbon _____						
Shaft runout	_____	Sleeve runout _____		Face-to-sleeve concentricity _____							
Test fluid	_____	Base-point temperature _____		Base-point pressure _____							
Relative density (SG)	_____	Vapor pressure _____		Solids _____		Particle size _____					
Test procedure	I.3.13 (for 2CW-CS, 2NC-CS Arrangements)					_____					
	I.3.15 (for 3NC-FF, 3NC-BB, 2NC-FB)					_____					

Data point	Date	Time	Inner seal		Buffer/barrier			Speed r/min	Seal leakage			
			Pressure	Temp.	Medium	Pressure	Temp.		Inner cm ³ /h	Outer		L/h (normalized)
			MPa (bar) (psi)	°C (°F)		MPa (bar) (psi)	°C (°F)			ml/m ³ (vol. ppm)	cm ³ /h	

Outer Seal Face Wear Stationary face _____ Rotating face _____ mm (in.)
 Inner Seal Face Wear Stationary face _____ Rotating face _____ mm (in.) (1.3.15 only)

Figure I.10—Mechanical Seal Qualification Test Form (2CW-CS, 2NC-CS, 3NC-FF, 3NC-BB, and 3NC-FB)

Bibliography

- [1] ISO 683-13:1986⁹, Heat-treatable steels, alloy steels and free-cutting steels—Part 13: Wrought stainless steels (withdrawn)
- [2] ISO 629, *Rubber and lattices—Nomenclature*
- [3] ISO 2858, *End-suction centrifugal pumps (rating 16 bar)—Designation, nominal duty point and dimensions*
- [4] ISO 2892, *Austenitic cast iron*
- [5] ISO 3506-1, *Mechanical properties of corrosion-resistant stainless-steel fasteners—Part 1: Bolts, screws and studs*
- [6] ISO 3506-2, *Mechanical properties of corrosion-resistant stainless-steel fasteners—Part 2: Nuts*
- [7] ISO 6208, *Nickel and nickel alloy plate, sheet and strip*
- [8] ISO 9327-5, *Steel forgings and rolled or forged bars for pressure purposes—Technical delivery conditions—Part 5: Stainless steels*
- [9] ISO 9723, *Nickel and nickel alloy bars*
- [10] ISO 9725, *Nickel and nickel alloy forgings*
- [11] ISO 12725, *Nickel and nickel alloy castings*
- [12] API 5L, *Specification for Line Pipe*
- [13] API Standard 614, *Lubrication, Shaft Sealing and Control-Oil Systems and Auxiliaries for Petroleum, Chemical and as Industry Services*
- [14] API Standard 676, *Positive Displacement Pumps—Rotary*
- [15] ASME B16.5¹⁰, *Pipe flanges and flange fittings, steel, nickel alloy and other special alloys*
- [16] ASME B31.3, *Process piping*
- [17] ASTM A53¹¹, *Zinc-coated welded and seamless black and hot-dipped steel pipe*
- [18] ASTM A105, *Carbon steel forgings for piping components*
- [19] ASTM A106, *Seamless carbon steel pipe for high temperature service*
- [20] ASTM A120, *Black and hot-dipped zinc-coated (galvanized) welded and seamless steel pipe for ordinary uses*

⁹ International Organization for Standardization, 1, ch. de la Voie-Creuse, Case postale 56, CH-1211 Geneva 20, Switzerland, www.iso.org.

¹⁰ ASME International, 3 Park Avenue, New York, New York 10016-5990, www.asme.org.

¹¹ ASTM International, 100 Barr Harbor Drive, West Conshohocken, Pennsylvania 19428, www.astm.org.

- [21] ASTM A181, *Carbon steel forgings for general purpose piping*
- [22] ASTM A182, *Forged or rolled alloy-steel pipe flanges, forged fittings, and valves and parts for high-temperature service*
- [23] ASTM A193, *Alloy-steel and stainless steel bolting materials for high-temperature service*
- [24] ASTM A194, *Carbon and alloy steel nuts for bolts for high-pressure and high-temperature service*
- [25] ASTM A197, *Cupola malleable iron*
- [26] ASTM A269, *Seamless and welded austenitic stainless steel tubing for general service*
- [27] ASTM A312, *Seamless and welded austenitic stainless steel pipe*
- [28] ASTM A338, *Malleable iron flanges, pipe fittings, and valve parts for railroad, marine, and other heavy duty service at temperatures up to 650 °F (345 °C)*
- [29] ASTM A524, *Seamless carbon steel pipe for atmospheric and lower temperatures*
- [30] ASTM A217, *Martensitic stainless and alloy steel castings for pressure-containing parts suitable for high temperature service*
- [31] ASTM A276, *Stainless and heat-resisting steel bars and shapes*
- [32] ASTM A351, *Austenitic steel castings for high-temperature service*
- [33] ASTM A436, *Austenitic gray iron castings*
- [34] ASTM A439, *Austenitic ductile iron castings*
- [35] ASTM A487, *Standard specification for steel castings suitable for pressure service*
- [36] ASTM A494, *Nickel and nickel alloy castings*
- [37] ASTM A582, *Standard specification for free-machining stainless steel bars*
- [38] ASTM A744, *Iron-chromium-nickel and nickel-base corrosion resistant castings for severe service*
- [39] ASTM B127, *Specification for nickel-copper alloy (UNS No4400) plate sheet and strip*
- [40] ASTM B164, *Specification for nickel-copper alloy rod, bar and wire*
- [41] ASTM B473, *Chromium-nickel-iron-molybdenum-copper-columbium stabilized alloy (UNS N08020) bar and wire*
- [42] ASTM B564, *Specification for nickel alloy forgings*
- [43] ASTM B574, *Specification for low-carbon and nickel-molybdenum-chromium and low-carbon nickel-chromium-molybdenum alloy rod*
- [44] ASTM B575, *Specification for low-carbon and nickel-molybdenum-chromium and low-carbon nickel-chromium-molybdenum alloy plate, sheet and strip*

- [45] ASTM B637, *Specification for precipitation hardening nickel alloy bars, forgings, and forging stock for high-temperature service*
- [46] ASTM A670, *Specification for precipitation hardening nickel alloy (UNS N07718) plate, sheet, and strip for high-temperature service*
- [47] ASTM D1418, *Practice for rubber and rubber lattices—Nomenclature*
- [48] EN 10088-3¹², *Stainless steels—Part 3: Technical delivery conditions for semi-finished products, bars, rods and sections for general purposes*
- [49] EN 10213-2, *Technical delivery conditions for steel castings for pressure purposes—Part 2: Steel grades for use at room temperature and elevated temperatures*
- [50] EN 10213-4, *Technical delivery conditions for steel castings for pressure purposes—Part 4: Austenitic and austenitic-ferritic steel grades*
- [51] EN 10222-5, *Steel forgings for pressure purposes—Part 5: Martensitic, austenitic and austenitic-ferritic stainless steels*
- [52] EN 10250-4, *Open die steel forgings for general engineering purposes—Part 4: Stainless steels*
- [53] EN 10269, *Steels and nickel alloys for fasteners with specified elevated and/or low temperature properties*
- [54] FSA 0010¹³, *Mechanical Seal Handbook*
- [55] HI¹⁴, *Mechanical Seals for Pumps: Application Guidelines, ISBN 1-880952-73-4*
- [56] JIS G 3214¹⁵, *Stainless steel forgings for pressure vessels*
- [57] JIS G 4303, *Stainless steel bars*
- [58] JIS G 4319, *Stainless steel blooms and billets for forgings*
- [59] JIS G 5121, *Stainless steel castings*
- [60] EC 1272/2008, *European Union Regulation on the classification, labeling and packaging of substances and mixtures*
- [61] EEC 67/548, *Dangerous Substances Directive*
- [62] Pruitt, Kenneth M., *Chemical Resistance for Elastomers III*, 2005
- [63] United Nations Globally Harmonised System of Classification and Labeling of Chemicals (GHS), 2009

¹² European Committee for Standardization, Avenue Marnix 17, B-1000 Brussels, Belgium, www.cen.eu.

¹³ Fluid Sealing Association, 994 Old Eagle School Road #1019, Wayne, Pennsylvania 19087, www.fluidsealing.com.

¹⁴ Hydraulic Institute, 6 Campus Drive, First Floor North, Parsippany, New Jersey 07054-4406, www.pumps.org.

¹⁵ Japanese Standards Association, www.jsa.or.jp.

EXPLORE SOME MORE

Check out more of API's certification and training programs, standards, statistics and publications.

API Monogram™ Licensing Program

Sales: 877-562-5187
(Toll-free U.S. and Canada)
(+1) 202-682-8041
(Local and International)
Email: certification@api.org
Web: www.api.org/monogram

API Quality Registrar (APIQR™)

- ISO 9001
- ISO/TS 29001
- ISO 14001
- OHSAS 18001
- API Spec Q1®
- API Spec Q2™
- API Quality *Plus*™
- Dual Registration

Sales: 877-562-5187
(Toll-free U.S. and Canada)
(+1) 202-682-8041
(Local and International)
Email: certification@api.org
Web: www.api.org/apiqr

API Training Provider Certification Program (API TPCP®)

Sales: 877-562-5187
(Toll-free U.S. and Canada)
(+1) 202-682-8041
(Local and International)
Email: tpcp@api.org
Web: www.api.org/tpcp

API Individual Certification Programs (ICP™)

Sales: 877-562-5187
(Toll-free U.S. and Canada)
(+1) 202-682-8041
(Local and International)
Email: icp@api.org
Web: www.api.org/icp

API Engine Oil Licensing and Certification System (EOLCS™)

Sales: 877-562-5187
(Toll-free U.S. and Canada)
(+1) 202-682-8041
(Local and International)
Email: eolcs@api.org
Web: www.api.org/eolcs

Motor Oil Matters™

Sales: 877-562-5187
(Toll-free U.S. and Canada)
(+1) 202-682-8041
(Local and International)
Email: motoroilmatters@api.org
Web: www.motoroilmatters.org

API Diesel Exhaust Fluid™ Certification Program

Sales: 877-562-5187
(Toll-free U.S. and Canada)
(+1) 202-682-8041
(Local and International)
Email: apidef@api.org
Web: www.apidef.org

API Perforator Design™ Registration Program

Sales: 877-562-5187
(Toll-free U.S. and Canada)
(+1) 202-682-8041
(Local and International)
Email: perfdesign@api.org
Web: www.api.org/perforators

API WorkSafe™

Sales: 877-562-5187
(Toll-free U.S. and Canada)
(+1) 202-682-8041
(Local and International)
Email: apiworksafe@api.org
Web: www.api.org/worksafe

API-U®

Sales: 877-562-5187
(Toll-free U.S. and Canada)
(+1) 202-682-8041
(Local and International)
Email: training@api.org
Web: www.api-u.org

API eMaintenance™

Sales: 877-562-5187
(Toll-free U.S. and Canada)
(+1) 202-682-8041
(Local and International)
Email: apiemaint@api.org
Web: www.apiemaintenance.com

API Standards

Sales: 877-562-5187
(Toll-free U.S. and Canada)
(+1) 202-682-8041
(Local and International)
Email: standards@api.org
Web: www.api.org/standards

API Data™

Sales: 877-562-5187
(Toll-free U.S. and Canada)
(+1) 202-682-8041
(Local and International)
Service: (+1) 202-682-8042
Email: data@api.org
Web: www.api.org/data

API Publications

Phone: 1-800-854-7179
(Toll-free U.S. and Canada)
(+1) 303-397-7956
(Local and International)
Fax: (+1) 303-397-2740
Web: www.api.org/pubs
global.ihs.com



AMERICAN PETROLEUM INSTITUTE

1220 L Street, NW
Washington, DC 20005-4070
USA

202-682-8000

Additional copies are available online at www.api.org/pubs

Phone Orders: 1-800-854-7179 (Toll-free in the U.S. and Canada)
303-397-7956 (Local and International)
Fax Orders: 303-397-2740

Information about API publications, programs and services is available
on the web at www.api.org.

Product No. C68204