

INTERNATIONAL
STANDARD

EN ISO 5199:2002

ISO
5199

Second edition
2002-03-15

Technical specifications for centrifugal
pumps — Class II

Spécifications techniques pour pompes centrifuges — Classe II



Reference number
ISO 5199:2002(E)

Contents	Page
Foreword.....	v
Introduction.....	vi
1 Scope	1
2 Normative references	1
3 Terms and definitions	2
4 Design	6
4.1 General.....	6
4.2 Prime movers	7
4.3 Critical speed, balance and vibration	8
4.4 Pressure-containing parts	9
4.5 Branches (nozzles) and miscellaneous connections	11
4.6 External forces and moments on flanges (inlet and outlet)	11
4.7 Branch (nozzle) flanges	12
4.8 Impellers	12
4.9 Wear rings or equivalent components	12
4.10 Running clearance.....	12
4.11 Shafts and shaft sleeves.....	12
4.12 Bearings	14
4.13 Shaft sealing	15
4.14 Labelling	18
4.15 Couplings	18
4.16 Baseplate.....	19
4.17 Special tools.....	20
5 Materials	20
5.1 Selection of materials.....	20
5.2 Material composition and quality.....	20
5.3 Repairs.....	20
6 Shop inspection and tests	20
6.1 General.....	20
6.2 Inspection.....	20
6.3 Tests.....	21
6.4 Final inspection	22
7 Preparation for dispatch	22
7.1 Shaft seals.....	22
7.2 Preservation for transport and storage.....	22
7.3 Securing of rotating parts for transport.....	23
7.4 Openings	23
7.5 Piping and auxiliaries.....	23
7.6 Identification	23
Annex A (normative) Centrifugal pump — Data sheet	24
Annex B (informative) External forces and moments on branches.....	27
Annex C (normative) Enquiry, proposal, purchase order.....	40
Annex D (normative) Documentation after purchase order	41
Annex E (informative) Examples of seal arrangements	42
Annex F (informative) Piping arrangements for seals.....	45

Annex G (informative) Designation examples using references from annexes E and F53
Annex H (informative) Checklist55
Bibliography57

Foreword

ISO (the International Organization for Standardization) is a worldwide federation of national standards bodies (ISO member bodies). The work of preparing International Standards is normally carried out through ISO technical committees. Each member body interested in a subject for which a technical committee has been established has the right to be represented on that committee. International organizations, governmental and non-governmental, in liaison with ISO, also take part in the work. ISO collaborates closely with the International Electrotechnical Commission (IEC) on all matters of electrotechnical standardization.

International Standards are drafted in accordance with the rules given in the ISO/IEC Directives, Part 3.

The main task of technical committees is to prepare International Standards. Draft International Standards adopted by the technical committees are circulated to the member bodies for voting. Publication as an International Standard requires approval by at least 75 % of the member bodies casting a vote.

Attention is drawn to the possibility that some of the elements of this International Standard may be the subject of patent rights. ISO shall not be held responsible for identifying any or all such patent rights.

International Standard ISO 5199 was prepared by Technical Committee ISO/TC 115, *Pumps*, Subcommittee SC 1, *Dimensions and technical specifications of pumps*.

This second edition cancels and replaces the first edition (ISO 5199:1986), which has been technically revised.

Annexes A, C and D form a normative part of this International Standard. Annexes B, E, F, G and H are for information only.

Introduction

This International Standard is one of a set dealing with technical specifications of centrifugal pumps; they are designated as Classes I, II and III. Class I comprises the most severe and Class III the least severe requirements.

The selection of the class to be used is in accordance with the technical requirements for the application for which the pump is intended. The class chosen should be agreed between the purchaser and supplier. Furthermore, additional safety requirements concerning the field of application should be taken into account.

However, it is not possible to standardize the class of technical requirements for centrifugal pumps for a certain field of application, because each field of application comprises different requirements. All classes (I, II and III) can be used in accordance to the different requirements of the pump application. So it may happen that pumps built in accordance with Classes I, II and III may work beside one another in the one plant.

Further requirements covering specific applications or industries may be dealt with in separate standards.

Criteria for the selection of the required class of a pump for a certain application may include

- reliability,
- required operating life,
- operating conditions,
- environmental conditions, and
- local ambient conditions.

Cross-references in boldface and the checklist in annex H indicate where a decision may be required by the purchaser, or where agreement is required between the purchaser and the manufacturer/supplier.

Technical specifications for centrifugal pumps — Class II

1 Scope

1.1 This International Standard specifies the requirements for Class II centrifugal pumps of single-stage, multistage, horizontal or vertical construction, with any drive and any installation for general application. Pumps used in the chemical process industries (e.g. those conforming to ISO 2858) are typical of those covered by this International Standard.

1.2 This International Standard includes design features concerned with installation, maintenance and safety for these pumps including baseplate, couplings and auxiliary piping, but it does not specify any requirements for the driver other than those related to its rated power output.

1.3 Where application of this International Standard has been called for and requires a specific design feature, alternative designs may be offered which meet the intent of this International Standard provided that the alternative is described in detail.

Pumps not complying with all the requirements of this International Standard may be offered for consideration provided that all deviations are stated.

2 Normative references

The following normative documents contain provisions which, through reference in this text, constitute provisions of this International Standard. For dated references, subsequent amendments to, or revisions of, any of these publications do not apply. However, parties to agreements based on this International Standard are encouraged to investigate the possibility of applying the most recent editions of the normative documents indicated below. For undated references, the latest edition of the normative document referred to applies. Members of ISO and IEC maintain registers of currently valid International Standards.

ISO 76, *Rolling bearings — Static load ratings*

ISO 281-1, *Rolling bearings — Dynamic load ratings and rating life — Part 1: Calculation methods*

ISO 2858, *End-suction centrifugal pumps (rating 16 bar) — Designation, nominal duty point and dimensions*

ISO 3069, *End-suction centrifugal pumps — Dimensions of cavities for mechanical seals and for soft packing*

ISO 3274, *Geometrical Product Specifications (GPS) — Surface texture: Profile method — Nominal characteristics of contact (stylus) instruments*

ISO 3661, *End-suction centrifugal pumps — Baseplate and installation dimensions*

ISO 3744, *Acoustics — Determination of sound power levels of noise sources using sound pressure — Engineering method in an essentially free field over a reflecting plane*

ISO 3746, *Acoustics — Determination of sound power levels of noise sources using sound pressure — Survey method using an enveloping measurement surface over a reflecting plane*

ISO 7005-1, *Metallic flanges — Part 1: Steel flanges*

ISO 7005-2, *Metallic flanges — Part 2: Cast iron flanges*

ISO 7005-3, *Metallic flanges — Part 3: Copper alloy and composite flanges*

ISO 9906, *Rotodynamic pumps — Hydraulic performance acceptance tests — Grades 1 and 2*

ISO 9614-1, *Acoustics — Determination of sound power levels of noise sources using sound intensity — Part 1: Measurement at discrete points*

ISO 9614-2, *Acoustics — Determination of sound power levels of noise sources using sound intensity — Part 2: Measurement by scanning*

3 Terms and definitions

For the purposes of this International Standard, the following terms and definitions apply.

3.1
operating conditions
all parameters (e.g. operating temperature, operating pressure) determined by a given application and pumped liquid

NOTE These parameters will influence the type of construction and construction materials.

3.2
allowable operating range
range of flows or heads at the specified operating conditions of the pump supplied as limited by cavitation, heating, vibration, noise, shaft deflection and other similar criteria

NOTE The upper and lower limits of the range are denoted by maximum and minimum continuous flow.

3.3
rated conditions
conditions (driver excluded) that define the guarantee values necessary to meet all defined operating conditions, taking into account any necessary margins

3.4
driver rated power output
greatest continuous driver power output permitted under defined conditions

3.5
basic design pressure
pressure derived from the permitted stresses at 20 °C of the material used for the pressure-containing parts

3.6
maximum allowable working pressure
pressure for a component on the basis of materials used and on the basis of calculation rules at the specified operating temperature

3.7
rated inlet pressure
inlet pressure of the operating conditions at the guarantee point

3.8
rated outlet pressure
outlet pressure of the pump at the guarantee point with rated flow, rated speed, rated inlet pressure and density

3.9

pressure/temperature limit

limiting pressure and temperature of a component at given design and material (see Figure 1)

3.10

corrosion allowance

that portion of the wall thickness of the parts wetted by the pumped liquid in excess of the theoretical thickness required to withstand the pressure limits given at the most severe operating conditions

3.11

maximum allowable continuous speed

highest speed at which the manufacturer will permit continuous operation

3.12

trip speed

speed at which the independent emergency overspeed devices operate to shut down a prime mover

3.13

first critical speed

speed of rotation at which the first (lowest) lateral natural frequency of vibration of the rotating parts corresponds to the frequency of rotation

3.14

design radial load

radial load of the pump rotor for which the bearing system is selected

3.15

maximum radial load

greatest radial load of the pump rotor resulting from operating the pump at any condition within its allowable operating range

3.16

shaft runout

total radial deviation indicated by a device measuring the shaft position in relation to the bearing housing, as the shaft is rotated manually in its bearings with the shaft in the horizontal position

3.17

face runout

total axial deviation indicated at the outer radial face of the shaft seal casing by a device attached to and rotated with the shaft when the shaft is rotated manually in its bearings in the horizontal position

NOTE The radial face is that which determines the alignment of a seal component.

3.18

shaft deflection

displacement of a shaft from its geometric centre in response to the radial hydraulic forces acting on the impeller

NOTE Shaft deflection does not include shaft movement caused by tilting within the bearing clearances, bending caused by impeller unbalance, or shaft runout.

3.19

seal flush

circulation

return of pumped liquid from high pressure area to seal cavity

NOTE This can be by external piping or internal passage and is used to remove heat generated at the seal or to maintain positive pressure in the seal cavity or treated to improve the working environment for the seal. In some cases it may be desirable to circulate from the seal cavity to a lower pressure area (e.g. the inlet).

3.20

injection flush

introduction of an appropriate (clean, compatible, etc.) liquid into the seal cavity from an external source and then into the pumped liquid

NOTE Injection flush is used for the same purpose as circulation and also to provide an improved working environment for the seal.

3.21

quenching

continuous or intermittent introduction of an appropriate (clean, compatible, etc.) fluid at lower than seal chamber pressure on the atmospheric side of the main shaft seal

NOTE It is used to exclude air or moisture, to prevent or clear deposits (including ice), lubricate an auxiliary seal, snuff out fire, dilute, heat or cool leakage.

3.22

barrier fluid

fluid which is introduced between dual mechanical seals to completely isolate the pump process liquid from the environment

NOTE The pressure of the barrier fluid is always higher than the process pressure being sealed.

3.23

buffer fluid

fluid used as a lubricant or buffer between dual mechanical seals

NOTE The fluid is always at a pressure lower than the pump process pressure being sealed.

3.24

pump H(Q) curve

pump head capacity curve

pump characteristic curve

relationship between the total head of the pump and the rate of flow at given operating/rated conditions of speed and liquid

3.25

net positive suction head 3 %

NPSH3

net positive suction head required to limit to 3 % the fall in the total head of the first stage of the pump

NOTE It is the basic standard used in performance curves.

See Figure 1.

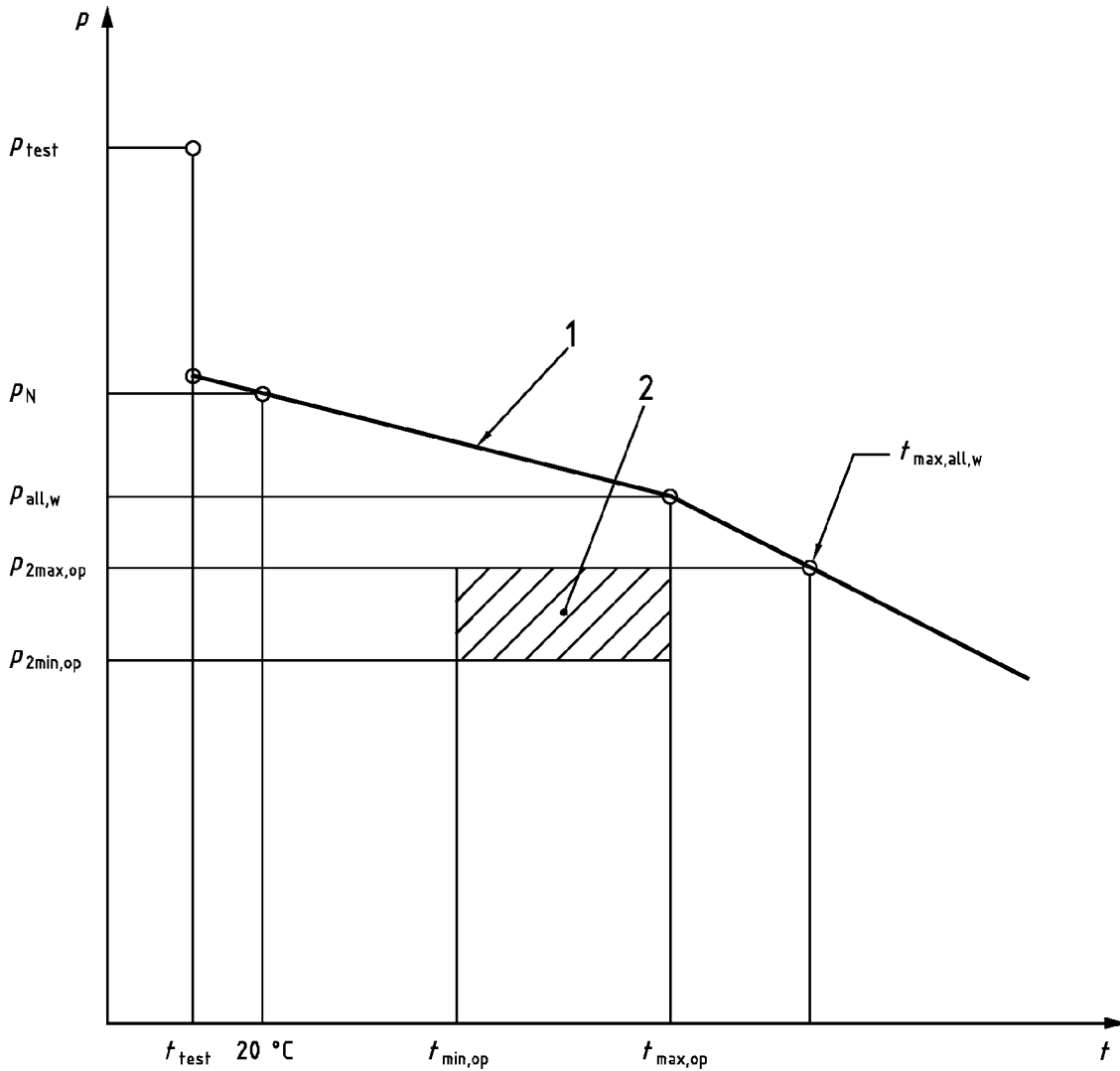

Key

- 1 Pressure-temperature limit of a component
- 2 Fluid operating field including tolerances

p	Pressure	t	Temperature
p_{test}	Hydrostatic test pressure	t_{test}	Hydrostatic test temperature
p_N	Basic design pressure	$t_{min,op}$	Minimum operating temperature
$p_{all,w}$	Maximum allowable working pressure	$t_{max,op}$	Maximum operating temperature
$p_{2max,op}$	Maximum outlet operating pressure	$t_{max,all w}$	Maximum allowable working temperature at maximum outlet pressure
$p_{2min,op}$	Minimum outlet operating pressure		

Figure 1 — Pressure-containing part, pressure/temperature rating

4 Design

4.1 General

4.1.1 Documents

Whenever the documents include conflicting technical requirements, they shall be applied in the following sequence:

- a) purchase order (or enquiry if no order is placed) (see annexes C and D);
- b) data sheet (see annex A);
- c) the requirements of this International Standard;
- d) other standards to which reference is made in the order (or enquiry if no order is placed).

4.1.2 Pump H(Q) curve (characteristic curve)

The manufacturer/supplier shall make available the characteristic curve which shall indicate the allowable operating range of the pump as supplied. Characteristic curves of the smallest and largest impeller diameter shall be plotted on the performance chart for pumps conforming to ISO 2858 and for other pump types when requested by the purchaser.

Pumps with a stable characteristic curve are preferred.

If specified by the purchaser, it shall be possible for pumps that are to be used with constant speed drives to increase the head by approximately 5 % at rated conditions by installing new, larger or different impeller or impellers.

The position of the duty point in the flow range relative to the best efficiency point should be decided by the purchaser as a function of the specific application and anticipated variation in flow for optimum operation.

4.1.3 Net positive suction head (NPSH)

The NPSH required (NPSHR) shall be based on cold water as determined by testing in accordance with ISO 9906 unless otherwise agreed.

The manufacturer/supplier shall make available the NPSHR curve as a function of flow for water. NPSHR curves shall be net positive suction head 3 % (NPSH3).

Correction factors for hydrocarbons shall not be applied to the NPSHR curves.

Pumps shall be selected such that the minimum NPSH available (NPSHA) in the installation exceeds the NPSHR of the pump by at least the specified safety margin. This safety margin shall be no less than 0,5 m but the manufacturer/supplier may specify a significantly higher margin depending on factors including the following:

- size, type, specific speed, hydraulic geometry or design of the pump;
- operating speed;
- the pumped liquid;
- the cavitation erosion resistance of the construction materials.

4.1.4 Outdoor installation

The pump shall be suitable for outdoor installation under environmental conditions specified by the manufacturer/supplier.

Any different local environmental conditions, such as high or low temperatures, corrosive environment, sand storms, for which the pump must be suitable shall be specified by the purchaser.

4.2 Prime movers

The following shall be considered when determining the rated performance of the drive:

- a) application and method of operation of the pump; for instance in the case of parallel operation, the possible performance range with only one pump in operation taking into account the system characteristic shall be considered;
- b) position of the operating point on the pump characteristic curve;
- c) shaft seal friction loss;
- d) circulation flow for the mechanical seal (especially for pumps with low rate of flow);
- e) properties of pumped liquid (viscosity, solids content, density);
- f) power and slip loss through transmission;
- g) atmospheric conditions at pump site;
- h) start-up of the pump.

In assessing the required speed torque characteristic of the driver, consideration shall be given to the system characteristics, in particular whether or not the pump is to be started manually or automatically with an open or closed discharge valve, or is to be used to fill the discharge main.

Prime movers required as drivers for any pumps covered by this International Standard shall have power output ratings at least equal to the percentage of rated pump power input given in Figure 2, this value never being less than 1 kW.

Where it appears that this will lead to unnecessary oversizing of the driver, an alternative proposal shall be submitted for the purchaser's approval.

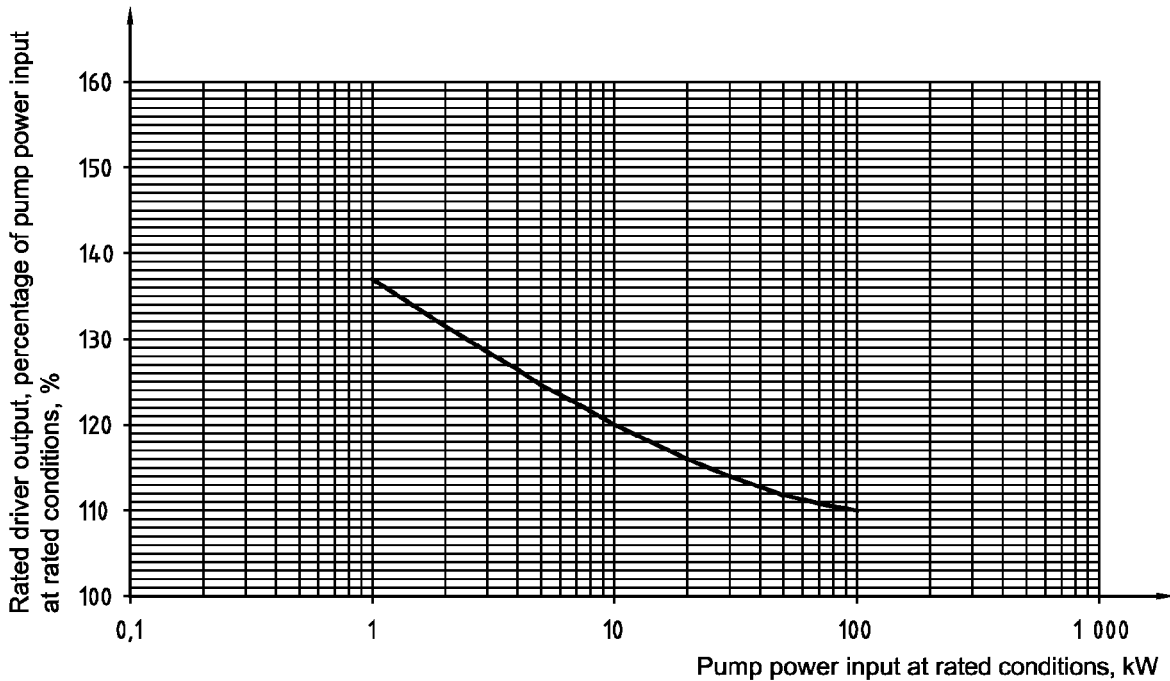

Figure 2 — Rated driver output, percentage of pump power input at rated conditions

4.3 Critical speed, balance and vibration

4.3.1 Critical speed

Under operating conditions, the actual first lateral critical speed of the rotor when coupled to the drive agreed upon shall be at least 10 % above the maximum allowable continuous speed including the trip speed of a turbine-driven pump.

For some pump types (e.g. vertical line shaft and horizontal multistage), the first critical speed may be below the operating speed when agreed between the purchaser and manufacturer/supplier. Particular attention shall be paid when the pump is to be driven at variable speeds.

4.3.2 Balance and vibration

4.3.2.1 General

All major rotating components shall be balanced.

4.3.2.2 Horizontal pumps

Unfiltered vibration shall not exceed the vibration severity limits as given in Table 1 when measured on the manufacturer/suppliers test facilities.¹⁾ These values are measured radially at the bearing housing at a single operating point at rated speed ($\pm 5\%$) and rated flow ($\pm 5\%$) when operating without cavitation.

1) Refer to ISO 10816-3 for *in situ* tests only.

Table 1 — Maximum allowable vibration severity

Pump arrangement	Pump type	Maximum values of r.m.s. vibration velocity, mm/s	
		$h \leq 225$	$h > 225$
Pump with rigid support	horizontal pumps	3,0	4,5
Pump with flexible support	horizontal pumps	4,5	7,1
All	vertical pumps	7,1	

In Table 1, h is the centreline height of the pump, and a rigid support is one where the lowest natural frequency of the combined machine and support system in the direction of measurement is at least 25 % higher than the rotational frequency. Any other support is considered flexible.

The manufacturer/supplier shall determine the grade of balancing required in order to achieve acceptable vibration levels within the limits specified in this International Standard.

NOTE For information, this can normally be achieved by balancing in accordance with grade G6.3 of ISO 1940-1.

The filtered values for rotating frequency and blade passing frequency may be expected to be lower than given in Table 1.

Pumps with a special impeller, for example a single channel impeller, may exceed the limits given in Table 1. In such a case the manufacturer/supplier should indicate this in his offer.

4.3.2.3 Vertical pumps

Vibration readings shall be taken on the top flange of the driver mounting on vertical pumps with rigid couplings, and near to the top pump bearing on vertical pumps with flexible couplings.

Vibration limits for both rolling and sleeve bearing pumps shall not exceed the vibration severity limits as given in Table 1 when measured on the manufacturer/suppliers test facilities at rated speed ($\pm 5\%$) and rated flow ($\pm 5\%$) operating without cavitation.

4.4 Pressure-containing parts

4.4.1 Pressure/temperature rating

The maximum allowable working pressure of the pump at the most severe operating conditions shall be clearly defined by the manufacturer. In no case shall the maximum allowable working pressure of the pump (casing and cover including shaft seal housing and gland follower/end plate) exceed that of the pump flanges (also see 4.5.2).

For pumps complying to ISO 2858 the following shall apply:

- the basic design pressure of the pump shall be at least a gauge pressure of 16 bar at 20 °C when made of cast iron, ductile iron, carbon steel or stainless steel;
- for materials the tensile requirements of which do not permit the 16 bar rating, the pressure/temperature rating shall be adjusted according to the stress temperature rating for the material and shall be clearly stated by the manufacturer/supplier.

4.4.2 Wall thickness

Pressure casings including the shaft seal housing and gland end plate shall be of such thickness as will be suitable for containing pressure and limiting distortion under the maximum allowable pressure at the operating temperature.

The casing shall also be suitable for the hydrostatic test pressure (see 6.3.3) at ambient temperature.

The pressure-containing parts shall have a corrosion allowance of 3 mm when required by the purchaser.

4.4.3 Materials

The materials used for pressure-containing parts shall depend on the liquid pumped and the application of the pump (see clause 5).

4.4.4 Mechanical features

4.4.4.1 Dismantling

With the exception of vertical lineshaft pumps and ring-section type multistage pumps, the pump preferably should be designed to permit removal of the impeller, shaft, shaft seal and bearing assembly without disturbing the inlet and outlet flange connections. For end-suction pumps where back pull-out construction is not available, this shall be stated by the manufacturer/supplier.

4.4.4.2 Jackscrews

When jackscrews are supplied as a means of separating contacting faces, one of the faces shall be relieved (counterbored or recessed) to avoid the possibility of creating a leak or poor fit. There shall be a sufficient number of jackscrews to ensure components can be separated without the need for undue force or risk of damage to the components. Hollow head screws should be avoided, if possible.

4.4.4.3 Jackets

Jackets for heating or cooling the casing or stuffing box, or both, are optional. Jackets shall be designed at an operating pressure of at least 6 bar at 170 °C. In certain applications it may be necessary to design heating jackets to 16 bar at 200 °C (for steam) or to 6 bar at 350 °C (for heat transfer oil).

4.4.4.4 Casing gaskets

Casing gaskets shall be of a design suitable for the hydrostatic test pressure of the pump. For radial split casings the casing-cover gaskets shall be confined on the atmospheric side to prevent blow-out.

4.4.4.5 Vapour venting

A pump handling a liquid at a pressure near its vapour pressure or with a gas content shall be designed so that the vapours can be properly vented.

4.4.4.6 External bolting

Bolts or studs that connect parts of the pressure casing, including shaft seal housing, shall be preferably not smaller than 12 mm diameter (ISO metric thread). If due to space limitations, the use of 12 mm bolts or studs is impractical, smaller bolts or studs may be used.

The bolting selected (property class) shall be adequate for the maximum allowable working pressure of the pump and for normal tightening procedures. If at some point it is necessary to use a fastener of special quality, interchangeable fasteners for other joints shall be of the same quality. Hollow-head screws should be avoided if possible.

4.4.4.7 Casing support for high temperature

For high temperature applications above 175 °C, due consideration should be given to supporting the pump casing at the centreline.

4.5 Branches (nozzles) and miscellaneous connections

4.5.1 Extent

For the purposes of this International Standard, the terms branch and nozzle are synonymous.

This subclause is concerned with all fluid connections to the pump whether for operation or maintenance.

4.5.2 Inlet and outlet branches

For end-suction pumps, inlet and outlet branches shall be flanged and designed for the same pressure rating. For other pump types (e.g. multistage pumps), different pressure ratings for inlet and outlet branches are permissible in which case the manufacturer/supplier shall state that this is so and emphasise the requirement for pressure relief.

4.5.3 Vent pressure-gauge and drain

Means for venting all areas of casing and seal chamber shall be provided unless the pump is made self-venting by arrangement of branches.

Provision shall be made for the connection of pressure gauges at the inlet and outlet branches but these connections shall not be drilled unless specified in the enquiry and/or order.

Provision shall be made for draining at the lowest point, or points of the pump. The enquiry and/or order should state whether such connections are required to be drilled and to be fitted with a plug or other closures.

4.5.4 Closures

The material for closures used in operation (plugs, blank/blind flanges, etc.) shall be appropriate for the pumped liquid. Attention shall be paid to the suitability of material combinations for corrosion resistance and to minimize the risk of seizure or galling of screw threads.

All openings exposed to the pumped liquid under pressure, including all shaft seal openings, shall be fitted with removable closures adequate to contain pressure.

4.5.5 Auxiliary pipe connections

All auxiliary pipe connections shall meet the compatibility requirements of material, size and thickness as specified for auxiliary piping (see 4.13.6).

Auxiliary piping shall be provided with detachable joints to permit easy dismantling. The type of connection shall be subject to agreement. In any case, connections equal to or greater than 25 mm diameter shall be flanged.

4.5.6 Connection identification

All connections shall be identified in the installation drawing in accordance with their duty and function. It is recommended that this identification also be applied on the pump.

4.6 External forces and moments on flanges (inlet and outlet)

The purchaser shall calculate the forces and moments exerted by the piping on the pump and check that they do not exceed allowable values. If the loads are higher than permissible, the solution shall be agreed between the purchaser and the manufacturer/supplier.

The method given in annex B is recommended to be used for pumps with flexible couplings unless another method is agreed upon between the purchaser and the manufacturer/supplier.

4.7 Branch (nozzle) flanges

The flange envelope shall be of a size to enable flanges in accordance with the relevant part of ISO 7005 to be provided. If the pump manufacturers standard pattern entails a flange thickness and a diameter greater than that of the rating specified, the heavier flange may be supplied, but it shall be faced and drilled as specified. Good seating of the bolt head and/or nut on the back face of cast flanges shall be ensured. Bolt holes shall straddle the centreline.

4.8 Impellers

4.8.1 Impeller design

Impellers of closed, semi-open or open designs may be selected according to the application. Cast or welded impellers shall consist of one piece, excluding wear rings.

Impellers fabricated by other means are permissible in special cases, i.e. for small impeller outlet widths or of special materials. This, however, requires agreement with the purchaser.

4.8.2 Securing of impellers

Impellers shall be secured against circumferential and axial movement when rotating in the intended direction.

4.8.3 Axial adjustment

If field adjustment of impeller axial clearance is required, external means shall be provided. If adjustment is achieved by axial movement of the rotor, attention shall be paid to the possibly dangerous effect on the mechanical seal(s) (see also 4.11.6).

4.9 Wear rings or equivalent components

Wear rings should be fitted where appropriate. When wear rings are fitted, they shall be renewable and securely locked to prevent rotation.

4.10 Running clearance

When establishing running clearances between stationary and moving parts, consideration shall be given to operating conditions and properties of materials used (such as hardness and gall resistance) for these parts. Clearances shall be sized to prevent contact under operating conditions, and material combinations selected to minimize the risk of seizure and erosion.

4.11 Shafts and shaft sleeves

4.11.1 General

Shafts shall be of ample size and stiffness

- a) to transmit the prime mover rated power,
- b) to minimize unsatisfactory packing or seal performance,
- c) to minimize wear and the risk of seizure, and
- d) to take due consideration of the static and dynamic radial loads, the critical speed (see 4.3.1) and the methods of starting and inertia loading involved.

4.11.2 Surface roughness

The surface roughness of the shaft or shaft sleeve at the stuffing box, mechanical seal and lubricant seal, if provided, shall be not greater than 0,8 μm R_a unless otherwise required for the seal. Consideration should be given to the use of lower levels of surface roughness (e.g. 0,4 μm R_a) for mechanical seals using axially dynamic shaft or sleeve seals. Measurement of surface roughness shall be in accordance with ISO 3274.

4.11.3 Shaft deflection

The calculated shaft deflection at the radial plane through the outer face of the stuffing box (or at the mechanical seal face for built-in seal pumps) caused by radial loads exerted during operation of the pump shall not exceed 50 μm , under the following conditions:

- a) within the allowable operating range of the pump;
- b) within the allowable operating range of the pump when fitted with maximum diameter impeller.

Condition a) always applies; in addition condition b) may be required by agreement.

Support by packing shall not be considered when determining shaft deflection.

4.11.4 Diameter

The diameter of the portions of the shaft or shaft sleeves in contact with the shaft seals shall be in accordance with ISO 3069 where practicable.

4.11.5 Shaft runout

Manufacture and assembly of the shaft and sleeve, if fitted, should ensure that the shaft runout at a radial plane through the outer face of the shaft seal casing is not greater than 50 μm for normal outside diameters smaller than 50 mm, not greater than 80 μm for nominal outside diameters 50 mm to 100 mm, and not greater than 100 μm for nominal outside diameters greater than 100 mm.

4.11.6 Axial movement

Axial movement of the rotor permitted by the bearings shall not adversely affect the performance of the mechanical seal.

4.11.7 Securing and sealing of shaft sleeve

When a shaft sleeve is fitted, it shall have a mechanism for axial location and circumferential drive sufficient for the maximum operating criteria prevailing. This shall also apply for the seal sleeve of cartridge mechanical seals if fitted.

Sealing shall be provided to prevent external leakage between the shaft and shaft sleeve. Where there is a risk of shaft corrosion, arrangements shall be made to ensure that the shaft is not wetted.

4.11.8 Arrangement of shaft sleeve

On a pump arranged for packing, the end of the shaft sleeve assembly, if fitted, shall extend beyond the outer face of the packing gland follower. On a pump arranged for mechanical seals, the shaft sleeve shall extend beyond the seal end plate. On pumps employing an auxiliary seal or a throttle bushing, the shaft sleeve shall extend beyond the seal end plate. Leakage between the shaft and sleeve thus cannot be confused with leakage through box packing or mechanical seal faces.

The arrangement of the shaft sleeve for external mechanical seals or multiple mechanical seals shall be fully described.

4.11.9 Securing of thrust bearing

Circlips in direct contact with the bearings shall not be used for transmitting the thrust from the shaft to the inner race of the thrust bearing. Locknuts and lockwashers are preferred.

4.12 Bearings

4.12.1 General

When rolling element bearings are fitted, they shall be in accordance with an internationally recognized standard. Other types of bearings may be used.

4.12.2 Rolling bearing life

Rolling bearings shall be selected and rated in accordance with ISO 76 and ISO 281-1; the basic rating life (L_{10}) shall be at least 17 500 h when operating within the allowable operating range. For end-suction pumps, the manufacturer/supplier shall specify the limits of the inlet pressure as a function of the pump head at maximum load to achieve a calculated bearing life of at least 17 500 h.

4.12.3 Bearing temperature

The pump manufacturer/supplier shall specify if cooling or heating is necessary to maintain bearing temperatures within the limits given by the bearing manufacturer.

4.12.4 Lubrication

The operation instructions shall include information on the type of lubricant to be used and the frequency of application.

4.12.5 Bearing housing design

In order to prevent loss or contamination, gasketed or threaded connections shall not be used to separate cooling or heating fluids from lubricants.

All openings in the bearing housing shall be designed to prevent the ingress of contaminants and the escape of lubricant under normal operating conditions.

In hazardous areas, any device for sealing the bearing housing shall be designed not to be a source of ignition. The use of lip seals should be avoided.

In case of oil lubrication, a plugged oil drain hole shall be provided.

If the bearing housing also serves as an oil chamber, an oil level indicator or constant level oiler shall be used. The mark for the recommended oil level or the setting of the constant level oiler shall be permanent and visible and shall state whether the level is stationary or running.

Where regreasable bearings are used, grease relief shall be provided.

At the bearing locations, the possibility of temperature and vibration monitoring shall be provided if requested by the purchaser.

4.13 Shaft sealing

4.13.1 General

For pumps complying to ISO 2858, the pump design shall permit the use of all the following alternatives:

- soft packing (P);
- single mechanical seal (S);
- multiple mechanical seal (D), as shown in annex E.

For all other pump types where the pump shaft has to be sealed, the pump design shall permit the use of one or more of the above alternatives.

The use of cartridge seals is permitted for all pump types.

Quench arrangements (Q), which in certain cases can become necessary, are also shown in annex E.

The seal cavity dimensions shall be in accordance with ISO 3069 except where the operating conditions dictate otherwise.

Arrangements shall be available for containing, collecting and draining all liquid leakage from the seal area.

4.13.2 Operating criteria for selection

Principal operating criteria for selection of mechanical seals and soft packings are

- chemical properties and the nature of the pumped liquid,
- minimum and maximum expected sealing pressure,
- temperature and physical properties of the liquid at the seal,
- special operating conditions (including start-up, shut-down, thermal and mechanical shocks, cleaning and sterilizing cycles, and
- shaft diameter and speed.

A supplementary criterion for mechanical seals is

- the direction of rotation of the pump.

4.13.3 Mechanical seals

4.13.3.1 Type and arrangement

This International Standard does not cover the design of the components of the mechanical seal but the components shall be suitable to withstand conditions specified in the data sheet (see annex A).

The arrangement (e.g. single, multiple, balanced or unbalanced mechanical seal; see annex E) shall be specified in the data sheet (see annex A).

If pumps handle liquids near their boiling point, the pressure in the mechanical seal chamber shall be sufficiently above the inlet pressure, or the temperature in the immediate vicinity of the seal shall be sufficiently below the vaporization temperature, to prevent vaporization at the seal faces.

If a multiple pressurized seal arrangement is applied (back-to-back or tandem), the barrier liquid between the seals shall be compatible with the process and at a pressure higher than the sealing pressure.

If a back-to-back mechanical seal is installed, it shall be ensured that the stationary ring on the impeller side and the adjacent rotating seal suffer no permanent displacement or irretrievable damage in the event of a transient, unplanned pressure drop in the barrier fluid.

For pumps operating at temperatures below 0 °C, quench may be provided to prevent ice formation.

4.13.3.2 Materials

Appropriate materials for the seal components shall be chosen to withstand corrosion, erosion, temperature, thermal and mechanical stress, etc. For mechanical seals, metallic parts wetted by the pumped liquid shall have at least the same material quality as the pump casing (see clause 5) as far as mechanical properties and corrosion resistance are concerned.

4.13.3.3 Construction features

Provision shall be made for centring the seal end plate in relation to the seal chamber bore. An inside or outside diameter register fit is an acceptable method of achieving this.

The seal end plate shall have sufficient rigidity to avoid distortion. The seal housing and end plate including fixing bolts (see 4.4.4.6) shall be designed for the permissible operating pressure at operating temperature and the required gasket seating load.

Gaskets between seal housing and stationary seal ring or seal end plate shall be externally confined or of equivalent design in order to prevent blow-out.

All stationary seal components, including the seal end plate, shall be protected from accidental contact with the shaft or sleeve, and from rotation. When a stationary sealing component contacts the shaft or sleeve, the surface in contact with the seal shall be adequately hard and corrosion resistant. Lead-ins shall be provided and sharp edges removed to prevent damage to the seal during fitting.

Machining tolerances of the seal chamber and the seal end plate shall restrict the face runout at the stationary seal ring of the mechanical seal to maximum permissible values as given by the seal manufacturer.

If throttle bushing is provided in the end plate to minimize leakage on complete failure of the seal, the diametral clearance, in millimetres, between bushing and shaft should be the minimum practical but in no case greater than

$$\frac{d}{100} + 0,2$$

where d is the shaft diameter.

Where leakage must be avoided, an auxiliary seal (for example, multiple seal) will be necessary (see annex E).

The seal chamber shall be designed to prevent trapping of air where practicable. If this is not possible, the seal chamber shall be ventable by the operator. The method of doing this shall be given in the instruction manual.

The position of liquid inlets and, if necessary, outlets from the seal chamber shall be suitable for the mechanical seal.

Holes may be drilled and tapped even where a connection is not required (see 4.5.3 and 4.5.5) unless otherwise agreed.

4.13.3.4 Assembly and test

For assembly for dispatch, see 7.1.

A mechanical seal shall not be subjected to a hydrostatic test pressure exceeding the seal pressure limit.

The purchaser shall be informed before ordering if seal faces are not suitable for operation with water (start-up conditions).

4.13.4 Stuffing box

Provision shall be made to allow fitting of a lantern ring. Connections where required shall be specified by either the purchaser or manufacturer/supplier. Ample space shall be provided for repacking without removing or dismantling any part other than gland components or guards. The gland components shall be positively retained even if the packing loses its compression.

4.13.5 Auxiliary piping for the stuffing box and mechanical seal

4.13.5.1 The pump shall be designed to accept such auxiliary piping as may be required by the shaft seal for the specified conditions.

4.13.5.2 Auxiliary piping may be required for the following.

Category a): service which involves process liquids or liquids that can enter the process:

circulation, if not by Internal passages;

injection (flushing);

barrier;

pressurising.

Category b): service for liquids which do not enter the process:

heating;

cooling;

buffer;

quenching.

4.13.6 Mechanical design of auxiliary piping

The range of supply and details of auxiliary piping and its connections provided for external services shall be agreed between the purchaser and manufacturer/supplier, and shall preferably be in accordance with annex F.

When specified, the piping system, including all accessories, shall be supplied by the pump manufacturer/supplier and fully assembled on the pump when possible.

The piping shall be designed and arranged to permit removal for maintenance and cleaning and shall be adequately supported to prevent damage due to vibration under normal operation and maintenance activities.

The inside pipe diameter shall always be at least 8 mm and the wall thickness 1 mm. Greater wall thickness and diameter are preferred.

The temperature and pressure rating of auxiliary piping handling process liquids [see 4.13.5.2 a)] shall not be less than that of the casing (see 6.3). The piping material shall resist corrosion caused by the liquid handled (see 4.5.5) and by environmental conditions.

Services piping [see 4.13.5.2 b)] shall be designed for the appropriate service design and temperature rating (see 4.4.4.3).

Drains and leakage outlets shall be provided at all low points to allow complete drainage. Piping shall be designed to avoid gas pockets.

Steam services shall be "top in, bottom out". In general other services should be "bottom or side in, top out".

If a restriction orifice is provided, its diameter shall preferably be not less than 3 mm.

When using adjustable orifices, a minimum continuous flow shall be ensured.

4.14 Labelling

4.14.1 Nameplates

Nameplates shall be made of corrosion-resistant material, suitable for the environmental conditions and shall be securely attached to the pump.

The minimum information required on the nameplate shall be the name (or trademark) and address of the manufacturer or supplier, identification number of the pump, (for example, serial number or product number), type and size.

Further space may be provided for additional information on the rate of flow, pump total head, pump speed, impeller diameter, (maximum and installed), maximum allowable working pressure and temperature of the pump, or other marking as required.

4.14.2 Direction of rotation

The direction of rotation shall be indicated in a distinctive place with a suitable arrow in a permanent form.

4.15 Couplings

The pump shall normally be coupled to the drive by flexible coupling. The coupling shall be sized to transmit the maximum torque of the intended driver. The speed limitation of the coupling shall correspond to all possible operating speeds of the intended pump driver.

A spacer coupling shall be provided where required to permit the pump rotor to be dismantled without moving the drive. Coupling spacer length is dependent on the distance required between shaft ends for dismantling the pump. The distance between the shaft ends should be in accordance with an International Standard²⁾ where possible.

A limited end float coupling shall be used if the drive has no thrust bearing.

Coupling halves shall be effectively secured against circumferential and axial movement relative to the shafts. Shaft ends shall have threaded centre bores, or other means shall be provided to ensure proper coupling assembly.

If coupling components are balanced together, the correct assembly position shall be shown by permanent and visible marks. Couplings and spacers shall have the same balancing grade as the pump impeller.

The permissible operating radial, axial and angular misalignment shall not exceed the limits given by the coupling manufacturer. Couplings shall be selected so that the operating conditions, such as temperature, torque variations, number of starts, pipe loads, and the rigidity of the pump and baseplate are taken into account.

2) Such as ISO 2858.

An appropriate coupling guard shall be provided. Guards shall be designed in accordance with national safety regulations.

If the pump is to be delivered without a drive system, the pump manufacturer and purchaser shall select the following components by common agreement:

- a) drive system: type, power, dimensions, mass, mounting method;
- b) coupling: type, manufacturer, dimensions, machining (bore and keyway), guard;
- c) speed range and power input.

4.16 Baseplate

4.16.1 General

Where applicable, the baseplate dimensions should preferably be in accordance with an International Standard (e.g. ISO 3661 for pump and motor).

It shall be agreed if the baseplates used for pumps according to ISO 2858 are other than those in accordance with ISO 3661.

The baseplate shall be designed to withstand external forces on pump branches given in 4.6 without exceeding the shaft misalignment given in annex B.

The material of the baseplate (e.g. cast iron, fabricated steel, concrete) and its installation (to be grouted or not) shall be agreed between the purchaser and supplier.

4.16.2 Non-grouted baseplates

Non-grouted baseplates shall be rigid enough to withstand the loads described in 4.6 for free-standing installation or for installation by bolting on a foundation without grouting.

4.16.3 Grouted baseplates

Baseplates requiring grouting shall be designed to ensure proper grouting, for example, trapping of air shall be prevented.

Where grout holes are necessary, they shall be not less than 100 mm in diameter or equivalent area and shall be accessible. Grout holes in a drained area shall have raised edges.

4.16.4 Baseplate design

Provision shall be made on the baseplate for collecting and draining leakage for all applications involving harmful liquids and for all other applications if requested by the purchaser. Draining areas should slope at least 1:100 in the direction of the drain port.

Connections for the drain shall be tapped at least 25 mm in diameter and located at the pump end of the baseplate.

4.16.5 Assembly of pump and driver on baseplate

4.16.5.1 Provision shall be made for vertical adjustment of the driver to permit compensation for the pump, driver and baseplate tolerances. This adjustment shall be not less than 3 mm and shall be made by using spacers or shims.

4.16.5.2 If the purchaser supplies a driver or coupling, he shall provide the pump manufacturer/supplier with certified installation dimensions of these components.

If the driver is not mounted by the pump manufacturer/supplier, the latter should provide and attach removable spacers for adjustment of shaft centreline heights if the total requirement for shim and spacer exceeds 25 mm. The driver fixing holes shall not be drilled unless otherwise agreed.

4.17 Special tools

Any tools which are specially designed for adjusting, assembling or dismantling the pump shall be supplied by the manufacturer/supplier.

5 Materials

5.1 Selection of materials

Materials are normally stated in the data sheet. If the materials are selected by the purchaser but the pump manufacturer/supplier considers other materials to be more suitable, these should be offered as alternatives by the manufacturer/supplier according to the operating conditions specified on the data sheet.

For hazardous liquids, the manufacturer/supplier shall propose suitable materials for agreement by the purchaser. Non-ductile materials should not be used for the pressure-containing parts of pumps handling flammable liquids.

For high or low temperature applications (i.e. above 175 °C or below –10 °C), the pump manufacturer/supplier shall give due consideration to mechanical design. For seal materials, see 4.13.3.2.

5.2 Material composition and quality

Chemical composition, mechanical properties, heat treatment and welding procedures shall be in accordance with the relevant material standards.

When tests and certificates for the above-mentioned properties are required, the procedures shall be agreed between the purchaser and supplier (see clause 6).

5.3 Repairs

Repairs by welding or other procedures shall be specifically related to the relevant material standards. The repair of leaks and defects in pressure casings by plugging, peening, painting or impregnation is prohibited.

6 Shop inspection and tests

6.1 General

6.1.1 Any or all of the following inspections and tests may be requested by the purchaser and where so requested they shall be specified in the data sheets (see annex A). Such tests may be witnessed or certified. The test reading sheets of witnessed tests shall be signed by the inspector and representative of the manufacturer/supplier. The certificates shall be issued by the manufacturer/supplier's quality control.

6.1.2 Where inspection is specified, the purchaser's inspector shall be granted access to the manufacturer/supplier's works at mutually agreed times and shall be given reasonable facilities and data to enable the inspection to be carried out satisfactorily.

6.2 Inspection

6.2.1 Pressure-containing parts shall not be painted except for anti-corrosion primer until testing and inspection are completed.

6.2.2 The following inspections may be required:

- a) examination of components before assembling;
- b) internal examination of the casing and wear ring after running of test;
- c) installation dimensions;
- d) information on the nameplate (see 4.14);
- e) auxiliary piping and additional equipment.

6.3 Tests

6.3.1 General

The purchaser shall specify the extent of his desired participation in the testing, follows.

- a) "Witnessed test" means that a hold shall be applied to the production schedule and the test carried out with the purchaser in attendance. It usually implies a double test.
- b) "Observed test" means that the purchaser requires notification of the timing of the test. However, the test is performed as scheduled, and if the purchaser is not present, the manufacturer/supplier may proceed to the next step. Since only one test is scheduled, the purchaser should expect to be in the factory longer than for a witnessed test.

6.3.2 Material tests

The following test certifications shall be available if requested in the purchase enquiry and order:

- a) chemical composition: according to manufacturer's standard specification or with specimen per melt;
- b) mechanical properties: according to manufacturer's standard specification or with specimen per melt and heat treatment;
- c) susceptibility to intergranular attack (where applicable);
- d) non-destructive tests (leakage, ultrasonic, dye penetrant, magnetic particle, radiographic, spectroscopic identification, etc.).

6.3.3 Hydrostatic test

6.3.3.1 All pressure-containing parts (e.g. casing, cover), including their fasteners, shall be hydrostatically tested with clean water at ambient temperature (15 °C minimum for carbon steel). The hydrostatic test shall be considered satisfactory when the test pressure is maintained for at least 10 min without visible leakage. Leakage through gaskets on temporary closures is acceptable provided it does not obscure observation of other leaks.

6.3.3.2 Care shall be taken in selecting the closure arrangements to avoid additional loading or restraint to the part under test having the effect of increasing or reducing the stresses and deformations resulting from the test pressure. Closure arrangements shall not obscure any leak. Through bolting shall not be used unless it is part of the normal construction.

6.3.3.3 The test pressure for all pressure-containing parts exposed to the pumped fluid including Category a) auxiliary piping (see 4.13.5.2) shall be at least 1,5 times the maximum allowable working pressure of the pump.

6.3.3.4 The test pressure for jackets and auxiliary piping according to Category b) (see 4.13.5.2) shall be at least 1,5 times their maximum allowable working pressure.

6.3.3.5 Where a part to be tested is to operate at a temperature at which the strength of the material will be below the strength of that material at room temperature, the hydrostatic test pressure shall be 1,5 times the maximum allowable working pressure adjusted to room temperature using the pressure temperature rating curve for that component, unless the hydrostatic test is performed at the elevated temperature. The data sheet shall list the actual hydrostatic test pressure.

6.3.3.6 If any hydrostatic test of the complete assembled pump is specified, overstrain of the auxiliary fittings such as gland packing or mechanical seal (see 4.13.3.5) shall be avoided. Leakage through soft packing or temporary mechanical seals is acceptable.

6.3.4 Performance test

6.3.4.1 Conversion methods for test liquids other than clean cold water and for different operating conditions (e.g. high inlet pressure) shall be agreed between the purchaser and manufacturer/supplier.

6.3.4.2 Hydraulic performance tests shall be in accordance with ISO 9906. The purchaser and manufacturer/supplier shall agree on the grade of testing required.

6.3.4.3 When required, the NPSH test shall be in accordance with ISO 9906 (see also 4.1.3).

6.3.4.4 During performance tests the following additional conditions may be checked:

- vibration (see 4.3);
- bearing temperature;
- seal leakage.

6.3.4.5 If a noise test is required, the test of airborne noise emitted by the pump shall be carried out in accordance with ISO 3744 and ISO 3746 or ISO 9614-1 or ISO 9614-2, by agreement between the purchaser and manufacturer/supplier.

6.4 Final inspection

A final inspection shall be carried out to verify whether the scope of supply is correct and complete according to the purchase order, including component identification, painting and preservation and documentation.

7 Preparation for dispatch

7.1 Shaft seals

Soft packings and mechanical seals are installed unless otherwise agreed. When the stuffing box is not packed, a warning label shall be securely attached to the pump.

7.2 Preservation for transport and storage

All internal parts made of material which are not resistant to corrosive attack by the environment shall be drained and treated with a water-displacing rust-preventative prior to shipment.

Exterior surfaces, except for machined surfaces, shall be given at least one coat of the manufacturer's standard paint which shall be selected taking into account environmental considerations. Stainless-steel parts need not be painted. Where applicable, the underside of baseplates shall be prepared for grout.

Exterior machined surfaces of cast iron and carbon steel parts shall be coated with a suitable rust preventative.

Bearings and bearing housings shall be protected by a preservative oil which is compatible with the lubricant. A label warning that oil lubricated bearing housings must be filled with oil to the proper level prior to starting shall be securely attached to the pump.

Information on preservation agents and their removal shall be securely attached to the pump. Local regulations concerning the use of protective agents should also be observed.

7.3 Securing of rotating parts for transport

In order to avoid damage to bearings caused by vibration during transport, rotating parts shall be secured as required according to the mode and distance of transport, the mass of the rotor and the bearings design. In such cases a warning label shall be securely attached.

7.4 Openings

All openings to the pressure chamber shall have weather-resistant closures substantial enough to withstand accidental damage (see also 4.5.4). Jacket closures shall not be capable of retaining pressure.

7.5 Piping and auxiliaries

Each unit shall be suitably prepared and small piping and auxiliaries secured, to prevent damage during shipment and storage.

7.6 Identification

The pump and all components supplied loose with it shall be clearly and durably marked with the prescribed identification number.

Annex A
(normative)

Centrifugal pump — Data sheet

A.1 General

If a data sheet is requested or required, the following centrifugal pump data sheet serves

the purchaser for enquiring, ordering and contract handling, and

the manufacturer/supplier for tendering and manufacturing.

The specification of the components is in accordance with this International Standard.

To provide more space for writing or typing, the data sheet may be enlarged and split in two pages but the line numbering in each case shall conform to the standard data sheet.

A.2 Instructions for completing the data sheet

The information required shall be indicated with a cross (x) in the appropriate column.

The fields shaded grey shall be completed by the purchaser for enquiry.

The blank columns may be used to indicate information required and also for revision marks indicating where information has been inserted or revised.

To facilitate communication about the information in an intended line and position of the column, use the following key.

a) For 3 columns:

		Column 1		Column 2		Column 3	
29	x		x		x		29

EXAMPLE Line 29/2.

Line No./Column No.

b) For 2 columns:

		Column 1		Column 2	
55	x		x		55

EXAMPLE Line 55/1.

Line No./Column No.

c) For 1 column:

		Column 1	
7	x		7

EXAMPLE Line 7

Line No.

Corporate name		Rotodynamic pump Data sheet						Revision:	
								Date:	
								Name:	
1	Plan	Service							
2		Specification class							
3	No. req.	Pump type and size	Manufacturer serial No.		Kind of driver	Drive, type, size		Item No.	
4	Operation								
5	Standby								
6	Drawings	Installation dimension			Pump weight	Pump content			
7		Assembly pump			Customer	Enquiry No.		Date	
8		Assembly shaft seal			Supplier	Order No.		Date	
9		Piping	Auxiliary system		Proposal No.		Date		
10		Shaft seal		Contract n°		Date			
11	Test	Material	Hydrostatic	Inspection	Performance	NPSH	Final inspection	Approved documents	
12	Reference								
13	Witnessed by								
Operating conditions									
14	Liquid		Flow	rated		NPSH at rated flow	Plant - NPSHA		
15	Solids	Type		max.			Pump - NPSH3		
16		% of mass	min.			Pump speed rated			
17	Corrosion by		Minimum flow required			Pump efficiency rated			
18	Operating temperature at t_{op}		Inlet gauge pressure	rated		Pump power input rated			
19	pH-value at t_{op}		max.			Pp. power input max.	at rated impeller diameter		
20	Density at t_{op}		Outlet gage pressure rated			at max. impeller diameter			
21	Vapour pressure at t_{op}		Differential pressure rated			Electric. driver power output rated			
22	Kinematic viscosity at t_{op}		Total head rated			Steam turbine power output rated			
23	Specific heat at t_{op}		Shut-off head			Performance curve No.			
Construction features									
24	Design		Max. allowable work. press.			Cooling water condition			
25	Number of stages		Test pressure			Cooling (C), Series (S)			
26	Self priming		Inlet flange	DN/Position		Heating (H), Parallel (P)	C	H	
27				PN/Facing			S	P	
28	Impeller diameter mm	max.	Outlet flange	PN/Facing		Bearing			
29		rated		DN/Position		Seal chamber			
30		min.				Cooler for seal flush			
30	Pump length vertical pumps		Vent connection			Oil cooler			
31	Barrel dimens. vert. pumps		Drain connection			Flush	Liquid		
32	Casing split		Shaft seal manufacturer			Lantern ring		Quantity	
33	Casing seal type		Type, size			Mechanical seal			
34	Impeller type		Flush plan (annex F)			Gland/Seal plate			
35	Casing support		Material code			Coupling	Manufacturer		
36	Rotation (looking from driver)		Soft packing ring dimension				Type, size.		
37	Axial thrust reduction by		Rad. bearing	Type			Diameter max.		
38	Total clearance	Impeller	Axial bearing	size		Spacer length			
39		Bal. drum	Line shaft bearing			Baseplate			
40		Shaft bushes	Bearing bracket No.			Anchor bolts suppl. by			
41	Wear plate	Lubrication			Driver	Supplied by			
42	Wall thickness rot sheath/stat. cas	Lubrication device			Mounted by				
Materials									
43	Casing		Bearing bush			Mecan. seal	Gland plate & gasket		
44	Discharge casing		Balance disc - drum				Rotary ring	Inner/outer	
45	Suction casing		Bal. counter disc-drum bus.				Static ring	Inner/outer.	
46	Stage casing		Containm.shell / Stat. casing				Spring or bellows		
47	Suction impeller		Rotor sheath / can			Seal metal parts			
48	Impeller		Magnet material			Rotary & Static ring seals			
49	Diffuser		Barrel			Stuffing box	Gland plate		
50	Wear ring casing		Column pipe				Soft packing ring		
51	Wear ring impeller		Bearing bracket				Lantern ring		
52	Wear plate / lining		Motor stool			Shaft sleeve			
53	Case bush		Coupling			Throat bush			
54	Casing gaskets		Coupling guard			Paint			
55	Shaft		Base plate						
Remarks:									
Customer:					Supplier:				
Prepared: (Date/Dep./Signature)			Checked: (Date/Dep./Signature)		Prepared: (Date/Dep./Signature)			Checked: (Date/Dep./Signature)	

Annex B (informative)

External forces and moments on branches

B.1 General

Forces and moments acting on the pump flanges due to pipe loads can cause misalignment of the pump and driver shafts, deformation and overstressing of the pump casing, or overstressing of the fixing bolts between the pump and baseplate.

This annex is intended to give manufacturers/suppliers, installation contractors and users of pumps a simple method for checking that loads transmitted to a pump by its piping remain within acceptable limits. This is done by comparing

the loads (forces and moments) calculated by the piping designer, with

the maximum values allowed on the flanges, as given in this annex for various pump families, as a function of their size and the installation conditions.

NOTE This method is part of the result of a study and tests undertaken within EUROPUMP (European Association of Pump Manufacturers) together with the support of piping specialists. The complete results are published as a CEN report (see reference [12]). The coefficients shown in Table B.5 for the families 1A, 1B and 3 were selected to give values for forces and moments approximately equal to those given in the CEN report. The family number may differ from the CEN report.

B.2 Definition of pump families

A certain number of pump families have been defined in accordance with the configuration of the pump and the most frequently used operating conditions.

The characteristics of the pump families are shown in Table B.1 for horizontal pumps and Table B.2 for vertical pumps.

If certain pumps do not have the characteristics mentioned in these tables, the manufacturer/supplier may consider them to be similar to one of the families of his choice, or else a special agreement should be signed between the purchaser and manufacturer/supplier for each particular case.

B.3 Allowable values of forces and moments

B.3.1 The maximum allowable forces and moments for each pump family are established by applying the appropriate coefficients to the basic values considered the most suitable for each pump family.

B.3.2 The basic values given in Table B.3 are applicable to each of the pump flanges, respecting the sign convention of the three axes through the flange.

Table B.1 — Characteristics of horizontal pump families

Family No.	General picture	Flange DN (max.)	Material
1A		200	Cast iron
1B		200	Cast steel
2		200 u 500	Cast iron
3		200	Cast steel
4A		200	Cast iron
4B		200	Cast steel
5A		150	Cast iron
5B		150	Cast steel
6A		600	Cast iron
6B		450	Cast steel

Table B.2 — Characteristics of vertical pump families

Family No.	General picture	Flange DN	Material
10A a, b		50 to 600	Cast iron
10B a, b			Cast steel
11A a		50 to 600	Cast iron
11B a			Cast steel
12A a		40 to 350	Cast iron
12B a			Cast steel
13A a		40 to 350	Cast iron
13B a			Cast steel
14A a		40 to 350	Cast iron
14B a			Cast steel
15A a		40 to 350	Cast iron
15B a			Cast steel

Table B.2 (continued)

16A		40 to 150	Cast iron
16B		40 to 200	Cast steel
17A		40 to 150	Cast iron
17B		40 to 200	Cast steel

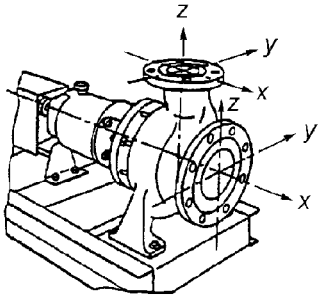
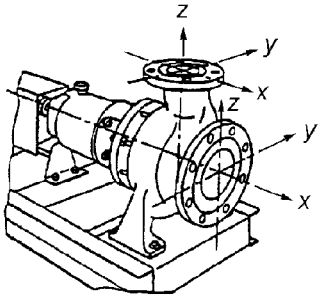
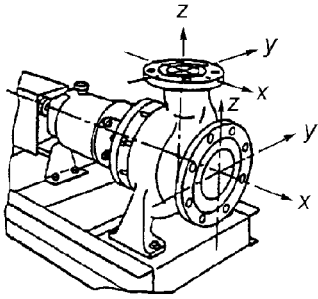
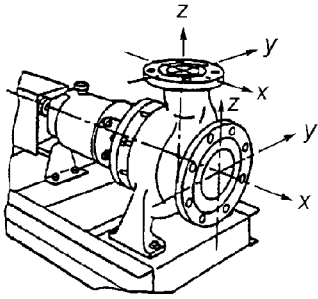
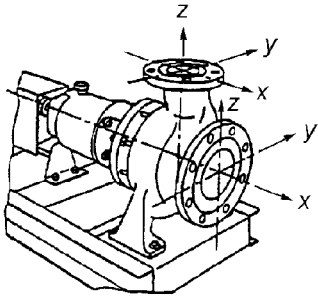
^a The allowable values of forces and moments for the families 10 to 15 in Tables B.3 and B.6 are only valid when the distance between the centreline of the flanges on which the loads are applied is within the limits indicated below.

$$A \text{ (mm)} \leq 1,5 \text{ DN}$$

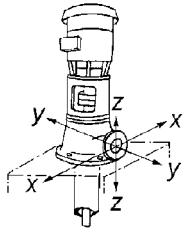
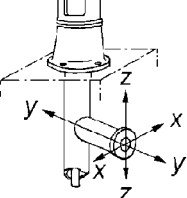
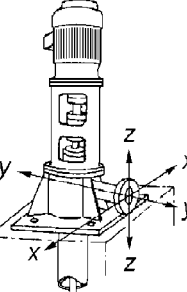
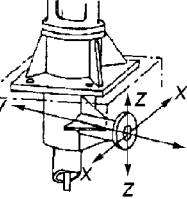
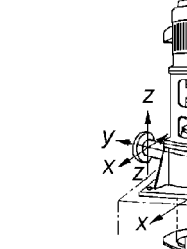
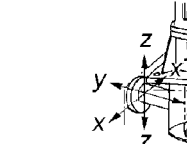
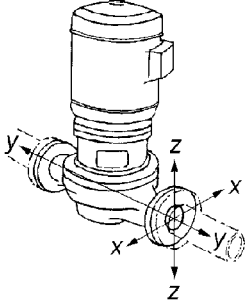
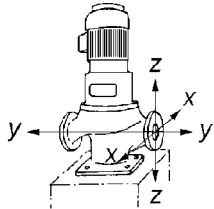
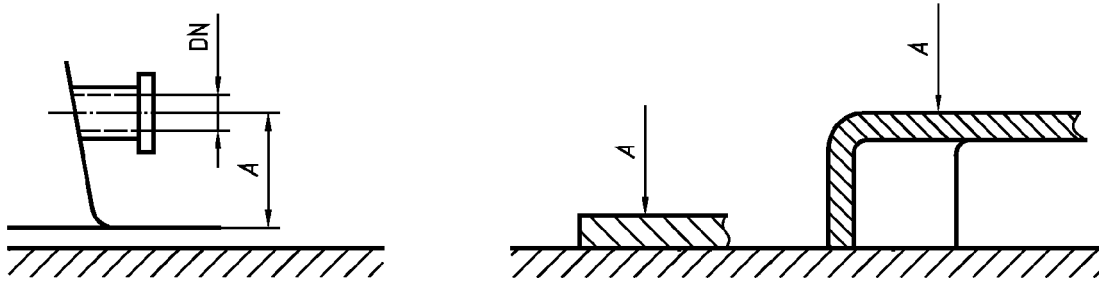

a) Flange above installation or fixing plane

$$B \text{ (mm)} \leq 1,8 \text{ DN}$$

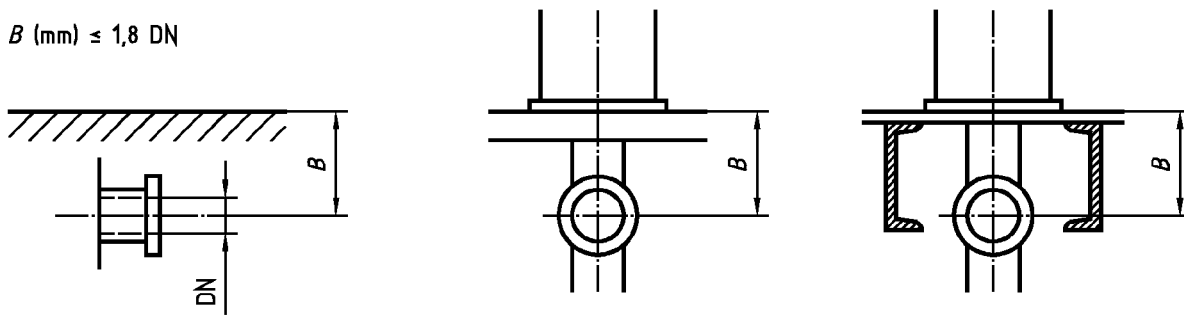

b) Flange below installation or fixing plane

^b For families 10A and 10B, the values given for the forces and moments are based on the assumption that the discharge elbow is monobloc with the driver stand, which itself serves as the supporting base of the complete pump unit. In the case of separate construction of this assembly (two or more components) the values indicated in Table B.6 must be divided by 2.

Table B.3 — Basic values of forces and moments for horizontal and vertical pumps

	Diameter ^a DN	Force N				Moment N·m			
		F_y	F_z	F_x	F^b	M_y	M_z	M_x	M^b
Horizontal pump Top branch z-Axis	25	700	850	750	1 300	600	700	900	1 300
	32	850	1 050	900	1 650	750	850	1 100	1 600
	40	1 000	1 250	1 100	1 950	900	1 050	1 300	1 900
	50	1 350	1 650	1 500	2 600	1 000	1 150	1 400	2 050
	65	1 700	2 100	1 850	3 300	1 100	1 200	1 500	2 200
	80	2 050	2 500	2 250	3 950	1 150	1 300	1 600	2 350
	100	2 700	3 350	3 000	5 250	1 250	1 450	1 750	2 600
	125	3 200	3 950	3 550	6 200	1 500	1 900	2 100	3 050
	150	4 050	5 000	4 500	7 850	1 750	2 050	2 500	3 650
	200	5 400	6 700	6 000	10 450	2 300	2 650	3 250	4 800
	250	6 750	8 350	7 450	13 050	3 150	3 650	4 450	6 550
	300	8 050	10 000	8 950	15 650	4 300	4 950	6 050	8 900
	350	9 400	11 650	10 450	18 250	5 500	6 350	7 750	11 400
	400	10 750	13 300	11 950	20 850	6 900	7 950	9 700	14 300
	450	12 100	14 950	13 450	23 450	8 500	9 800	11 950	17 600
	500	13 450	16 600	14 950	26 050	10 250	11 800	14 450	21 300
550	14 800	18 250	16 450	28 650	12 200	14 050	17 100	25 300	
600	16 150	19 900	17 950	31 250	14 400	16 600	20 200	29 900	
Horizontal pump Side branch y-Axis	25	850	700	750	1 300	600	700	900	1 300
	32	1 050	850	900	1 650	750	850	1 100	1 600
	40	1 250	1 000	1 100	1 950	900	1 050	1 300	1 900
	50	1 650	1 350	1 500	2 600	1 000	1 150	1 400	2 050
	65	2 100	1 700	1 850	3 300	1 100	1 200	1 500	2 200

Table B.3 (continued)

	Diameter ^a DN	Force N				Moment N·m			
		F_y	F_z	F_x	F^b	M_y	M_z	M_x	M^b
Vertical pump Side branch at right angles to shaft y-Axis	80	2 500	2 050	2 250	3 950	1 150	1 300	1 600	2 350
	100	3 350	2 700	3 000	5 250	1 250	1 450	1 750	2 600
	125	3 950	3 200	3 550	6 200	1 500	1 900	2 100	3 050
	150	5 000	4 050	4 500	7 850	1 750	2 050	2 500	3 650
	200	6 700	5 400	6 000	10 450	2 300	2 650	3 250	4 800
	250	8 350	6 750	7 450	13 050	3 150	3 650	4 450	6 550
	300	10 000	8 050	8 950	15 650	4 300	4 950	6 050	8 900
	350	11 650	9 400	10 450	18 250	5 500	6 350	7 750	11 400
	400	13 300	10 750	11 950	20 850	6 900	7 950	9 700	14 300
	450	14 950	12 100	13 450	23 450	8 500	9 800	11 950	17 600
	500	16 600	13 450	14 950	26 050	10 250	11 800	14 450	21 300
	550	18 250	14 800	16 450	28 650	12 200	14 050	17 100	25 300
600	19 900	16 150	17 950	31 250	14 400	16 600	20 200	29 900	
Horizontal pump End branch x-Axis	25	750	700	850	1 300	600	700	900	1 300
	32	900	850	1 050	1 650	750	850	1 100	1 600
	40	1 100	1 000	1 250	1 950	900	1 050	1 300	1 900
	50	1 500	1 350	1 650	2 600	1 000	1 150	1 400	2 050
	65	1 850	1 700	2 100	3 300	1 100	1 200	1 500	2 200
	80	2 250	2 050	2 500	3 950	1 150	1 300	1 600	2 350
	100	3 000	2 700	3 350	5 250	1 250	1 450	1 750	2 600
	125	3 550	3 200	3 950	6 200	1 500	1 900	2 100	3 050
	150	4 500	4 050	5 000	7 850	1 750	2 050	2 500	3 650
	200	6 000	5 400	6 700	10 450	2 300	2 650	3 250	4 800
	250	7 450	6 750	8 350	13 050	3 150	3 650	4 450	6 550
	300	8 950	8 050	10 000	15 650	4 300	4 950	6 050	8 900
	350	10 450	9 400	11 650	18 250	5 500	6 350	7 750	11 400
	400	11 950	10 750	13 300	20 850	6 900	7 950	9 700	14 300
	450	13 450	12 100	14 950	23 450	8 500	9 800	11 950	17 600
	500	14 950	13 450	16 600	26 050	10 250	11 800	14 450	21 300
550	16 450	14 800	18 250	28 650	12 200	14 050	17 100	25 300	
600	17 950	16 150	19 900	31 250	14 400	16 600	20 200	29 900	

^a For DN values exceeding 600, or the flange maximum DN value in Tables B.1 and B.2, agreement shall be reached between the purchaser and manufacturer/supplier on the values of forces and moments.

^b F and M are the vector sums of the forces and moments.

B.3.3 Under the maximum allowable forces and moments, the lateral displacement of the shaft end, relative to the fixed point in space should not exceed the values indicated for the pump families in Table B.4.

Table B.4 — Lateral displacement

Type of pump	Families	Shaft-end diameter	Displacement ^a
		mm	mm
Horizontal pumps	1A, 1B, 2, 3, 4A, 4B	< 30	0,15
		31 to 40	0,20
		> 40	0,25
	5A, 5B, 6A, 6B	50	0,15
> 50		0,175	
Vertical pumps	All (10A to 17B)	All	0,150

^a The displacement values given are for reference in checking the stiffness of the pump and its supports and are not the same as the alignment requirements (see B.6).

B.3.4 The basic values mentioned in Table B.3 should be multiplied, for the family of pumps concerned, by the corresponding coefficient as given in Table B.5 or B.6.

B.3.5 The values shown in Table B.5 and B.6 are valid for the materials specified in Tables B.1 and B.2. For other materials they must be corrected proportionately to the ratio of their modulus of elasticity at the appropriate temperature (see B.4.5).

B.3.6 The values can be applied simultaneously in all directions with positive or negative signs, or separately on each flange (suction and discharge).

B.3.7 The basic values in Table B.5 are given for pumps with baseplates for standard construction and installation as specified by the manufacturer/supplier.

Table B.5 — Basic values of forces and moments for horizontal and vertical pumps

Pump family No.	Coefficient/values	
	Force	Moment
1A	0,35	0,35
1B	0,7	0,7
2	0,4	0,4
3	1	1
4A	0,35	0,35
4B	0,6	0,6
5A	0,3	($M - 500 \text{ N}\cdot\text{m}$) ¥ 0,35
5B	0,6	($M - 500 \text{ N}\cdot\text{m}$) ¥ 0,70
6A	0,4	0,3
6B	1	1

Table B.6 — Coefficients for actual values of vertical pumps

Pump family No.	Coefficient/values	
	Force	Moment
10A ^a	0,3	0,3
10B ^a	0,6	0,6
11A	0,1	0,1
11B	0,2	0,2
12A	0,375	$M_y M_z M_x (-500 \text{ N}\cdot\text{m}) \neq 0,5$
12B	0,75	$M_y M_z M_x (-500 \text{ N}\cdot\text{m}) \neq 1$
13A	0,262	$M_y M_z M_x (-500 \text{ N}\cdot\text{m}) \neq 0,35$
13B	0,525	$M_y M_z M_x (-500 \text{ N}\cdot\text{m}) \neq 0,7$
14A	0,375	$M_y M_z M_x (-500 \text{ N}\cdot\text{m}) \neq 0,5$
14B	0,75	$M_y M_z M_x (-500 \text{ N}\cdot\text{m}) \neq 1$
15A	0,262	$M_y M_z M_x (-500 \text{ N}\cdot\text{m}) \neq 0,35$
15B	0,525	$M_y M_z M_x (-500 \text{ N}\cdot\text{m}) \neq 0,7$
16A	0,5	0,5
16B	1	1
17A	0,375	$M_y M_z M_x (-500 \text{ N}\cdot\text{m}) \neq 0,5$
17B	0,75	$M_y M_z M_x (-500 \text{ N}\cdot\text{m}) \neq 1$

^a The coefficients are given for a maximum working pressure of 20 bar. For much lower pressures, which justify light fabricated construction, the coefficients must be reduced in direct proportion to the pressure, with a minimum limit of 0,2. This is the case for pumps of very high specific speed (e.g. propeller pumps).

B.4 Possibilities for increasing the basic values

B.4.1 General

It is possible, if the concept of the piping requires it, to offer the user an increase in the basic values in order to facilitate the design and construction of the piping system.

B.4.2 Horizontal pumps

Two types of possibilities should be taken into consideration for horizontal pumps:

- a) reinforced baseplates, which are the manufacturer/supplier's responsibility;
- b) installation adjustments, which are the users responsibility,
 - pumps at shut-down with or without realignment,
 - pre-loading.

B.4.3 Vertical pumps

For vertical pumps, only the families 12B, 14B, 15B, 16B and 17B may take advantage of these additional possibilities. The following are excluded:

- shut-down pumps, with or without realignment;
- reinforced or grouted baseplates.

The only possibilities applicable are therefore the following:

- pre-loading the piping;
- use of a weighting or compensation formula;
- a combination of the two possibilities.

The pre-loading of piping is not applicable for family 16B.

If these additional possibilities are to be applied, a prior agreement between the purchaser and manufacturer/-supplier should be reached.

B.4.4 Weighting or compensation formula

When the applied loads do not all attain the maximum values allowed, one of these loads may exceed the normal limit, provided that the following supplementary conditions are satisfied:

- any component of a force or of a moment shall be limited to 1,4 times the maximum allowable value;
- the actual forces and moments acting on each flange are governed by the following formula:

$$\frac{\hat{E} \hat{A} |F|_{\text{actual}}}{\hat{E} \hat{A} |F|_{\text{max,allow.}}}^2 + \frac{\hat{E} \hat{A} |M|_{\text{actual}}}{\hat{E} \hat{A} |M|_{\text{max,allow.}}}^2 \leq 2$$

in which the total loads $S_{F\dot{A}}$ and $S_{M\dot{A}}$ are the arithmetic sums for each flange (inlet and outlet), for both the actual and maximum allowable values without taking into account their algebraic sign, at the level of the pump (inlet flange + outlet flange).

B.4.5 Influence of material and temperature

In the absence of any counter-indication, all values of forces and moments are given for the base material of the pump family, as shown in Tables B.1 and B.2, and for a basic temperature of 20 °C.

Above this temperature, and for other materials, the values should be corrected in function of the ratio of their moduli of elasticity, as follows:

$$\frac{E_{t,m}}{E_{20,b}}$$

where

$E_{20,b}$ is the modulus of elasticity of the base material at 20 °C;

$E_{t,m}$ is the modulus of elasticity of the material chosen at pumping temperature t .

The variation of modulus of elasticity as a function of the temperature is given for some common materials in Figure B.1.

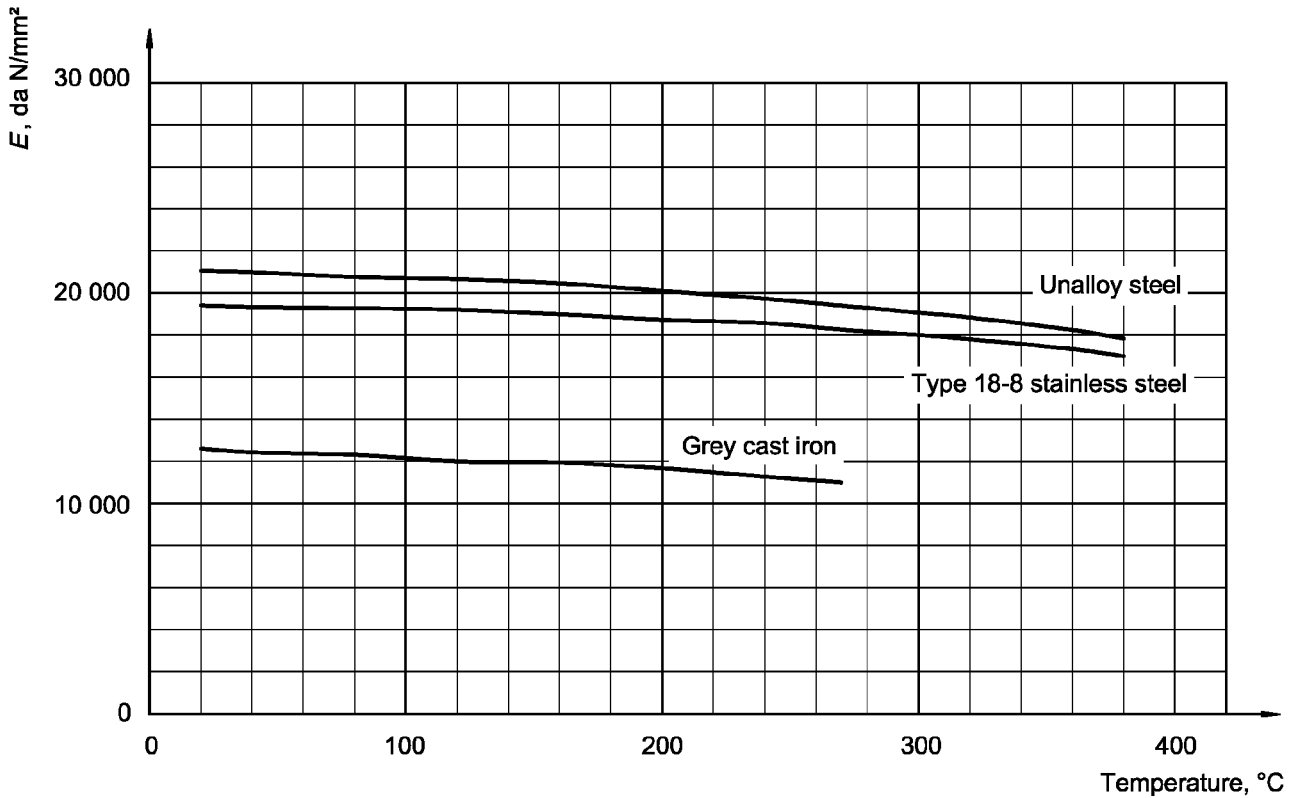

Figure B.1 — Variation of modulus of elasticity E as a function of temperature

B.4.6 Example of the calculation of the maximum permitted forces and moments on flanges

a) Pump type:

Multistage pump, horizontal

Flange suction side: DN 65, side branch

Flange discharge side: DN 50, top branch

Material: cast iron

Temperature: 110 °C

b) Proceeding:

Definition of the pump family number according to Table B.1 (5A)

Determine the forces:

Diameter DN	Force (Table B.3)		Coefficient (Table B.5)	Permissible force N
		N		
50	F_y	1 350	$F_y \neq 0,3$	405
	F_x	1 500	$F_x \neq 0,3$	450
	F_z	1 650	$F_z \neq 0,3$	495
	F	2 600	$F \neq 0,3$	780
65	F_y	2 100	$F_y \neq 0,3$	630
	F_x	1 850	$F_x \neq 0,3$	555
	F_z	1 700	$F_z \neq 0,3$	510
	F	3 300	$F \neq 0,3$	990

Determine the moments:

Diameter DN	Sum of moments (Table B.3)		Coefficient (Table B.4)	Permissible moment N·m
		N·m		
50		2 050	$(M - 500 \text{ N·m}) \neq 0,35$	542,5
65		2 200	$(M - 500 \text{ N·m}) \neq 0,35$	595,0

$$\frac{E_{110 \text{ C}}}{E_{20 \text{ C}}} = \frac{120000}{126000} = 0,9524$$

Influence of temperature (see B.4.3 and Figure B.1)

Correction of forces and moments for temperature of 110 °C by factor 0,9524

c) Result:

Diameter DN	Forces N		Moments N·m	
	50	F_y	386	M
F_x		429		
F_z		471		
F		743		
65	F_y	600	M	568
	F_x	529		
	F_z	486		
	F	943		

B.5 Responsibilities of the manufacturer/supplier and purchaser

The manufacturer/supplier should indicate to the purchaser the family to which the proposed equipment belongs.

The two parties should agree on the type of baseplate to be used (standard, reinforced, concreted to foundation).

The purchaser (or the erection contractor, engineering consultant, etc.) should calculate the loads applied to the pump at its flanges, considered to be fixed, under all conditions (hot, cold, shutdown, under pressure).

The purchaser should ascertain that the values of these loads do not exceed the limits given in the appropriate table for the pump selected. If they do, then either the piping should be modified to reduce these loads, or another type of pump, capable of withstanding higher loads, should be chosen.

B.6 Practical considerations

B.6.1 A pump is not a static element of a piping system, but a precision machine comprising a moving part running at high speed with minimal clearance and possessing high-precision sealing elements such as mechanical seals. Therefore, it is important to remain within the maximum limits authorized by this specification whenever possible.

B.6.2 This specification, agreed upon and jointly set up by the manufacturer/supplier and user in their mutual best interests, points out the following recommendations.

- a) The initial alignment of the pump-driver coupling should be made with great care and should be periodically checked according to the instructions of the pump or coupling manufacturer.
- b) Coupling with a spacer piece having two articulated connecting points is always preferable, especially for a large pumping unit and/or a system concerning fluids at temperatures exceeding 250 °C.
- c) The piping connections, during initial erection, should be made strictly according to rules and respecting the instructions given by the pump manufacturer/supplier or designer of the piping system. A check is recommended every time there is a possibility to partially or totally dismantle the pumping unit.
- d) According to the type of pump involved and the temperature during service, in certain cases the initial alignment of the coupling should be made at a temperature higher than ambient.

The manufacturer/supplier and the user will have to define very strictly the assembly conditions and the coupling alignment, should this solution be adopted.

B.6.3 Vertical pumps, other than the monobloc "inline" type, have the special feature of a long or fairly long lineshaft, running in sleeve bearings spaced at regular intervals, often lubricated by the pumped liquid. As a result, smooth operation of the rotating assembly depends upon good alignment. This can only be ensured if the external constraints applied to the pump flanges do not cause distortions greater than those allowed by the manufacturer/supplier.

This is why, in view of the design concept of vertical pumps and their sensitivity to misalignment, the present code limits the forces and moments on their flanges to values lower than those allowed on horizontal pumps.

Furthermore, visual assessment of distortion at the level of the coupling is not as easy as in the case of horizontal pumps, since the motor and its stool are often closely connected to the upper part of the pump. Such distortions can in fact only be related to a fixed reference point in space. Verification being difficult, the user should follow closely the recommendations given by the manufacturer/supplier.

Excessive loads on the flanges, in addition to compromising good operation and/or reliability, usually give rise to

a vibration level greater than normal, and

difficulty in turning the rotor by hand at rest (at the operating temperature), when the mass of the rotor allows such hand-turning.

Annex C
(normative)

Enquiry, proposal, purchase order

C.1 Enquiry

The enquiry shall include the data sheet with the technical information indicated by fields shaded grey.

C.2 Proposal

The proposal shall include the following technical information:

- completed data sheet, where indicated by "X";
- preliminary outline drawing;
- typical cross-section drawing;
- characteristic curve.

C.3 Purchase order

The purchase order shall include the following technical information:

- completed data sheet;
- required documentation.

Annex D
(normative)

Documentation after purchase order

D.1 The required number of copies of the following certified documents shall be supplied to the purchaser at the agreed time.

Any special style or form of documentation shall be a matter of agreement.

D.2 Normally the documentation consists of the following:

data sheet;

dimensioned outline drawing;

instruction manual, including information for installation, commissioning (preparation for first start-up), operation, shutdown, maintenance (monitoring, servicing and repair) including cross-section drawings, with part list, running tolerances, etc., and if necessary special instructions for specific operating conditions;

performance curves;

spare parts list.

D.3 The documentation shall be clearly identified by

item number,

purchase order number, and

manufacturer/supplier order number.

Annex E
(informative)

Examples of seal arrangements

E.1 General

Figures E.1 to E.4 show the principles of seal arrangements and not details of their construction.

E.2 Soft packing³ (P)

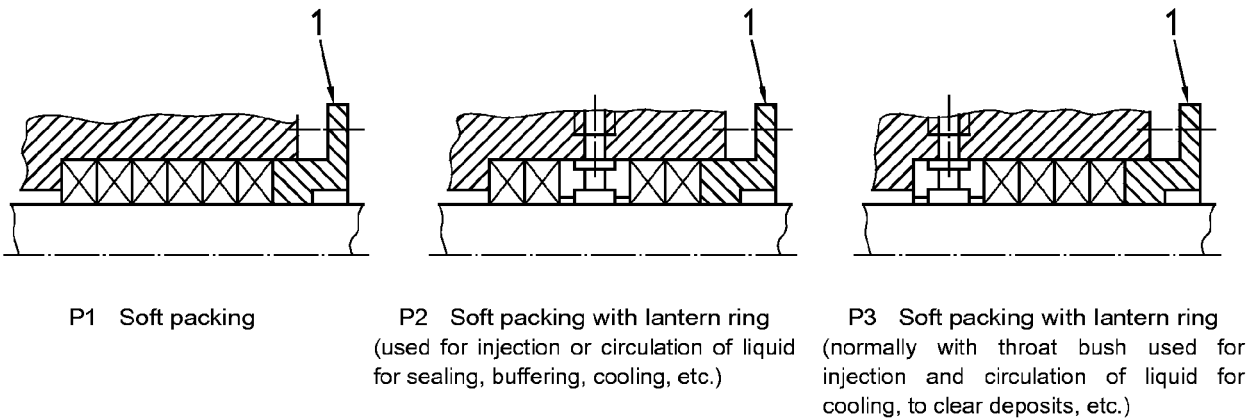

Key

1 Gland follower

Figure E.1 — Examples of soft packing

E.3 Single mechanical seal³ (S)

These seals can be:

- a) unbalanced (U) (as in Figure E.2), balanced (B) or bellows (Z) normally;
- b) with or without circulation or injection to the sealed faces;
- c) with or without throat bush.

³ Left-hand side of figures shows the pump side, right-hand side shows the atmospheric side.

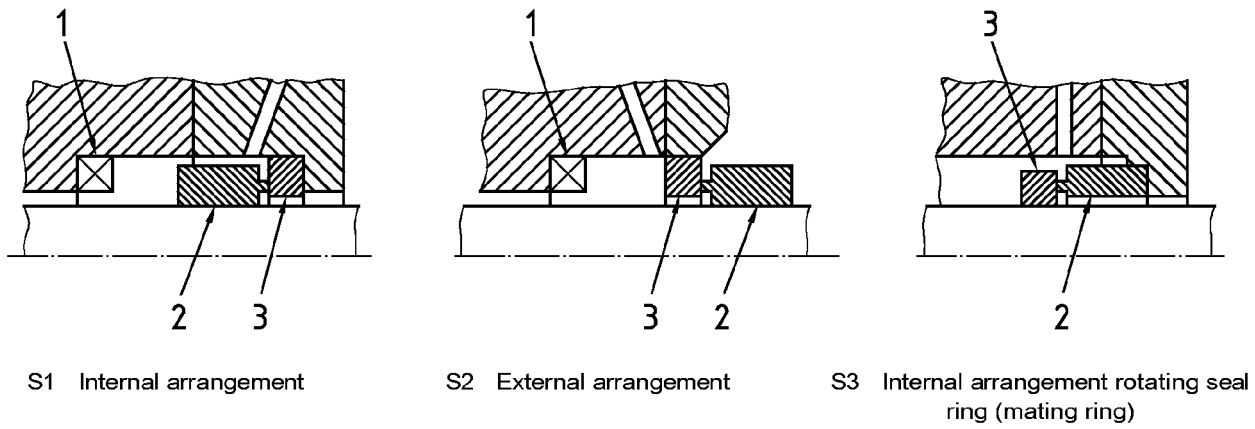

Key

- 1 Throat brush
- 2 Spring-loaded ring
- 3 Seat ring

Figure E.2 — Examples of single mechanical seals

E.4 Multiple mechanical seal³⁾ (D)

Either or both of these seals may be unbalanced (as in Figure E.3) or balanced.

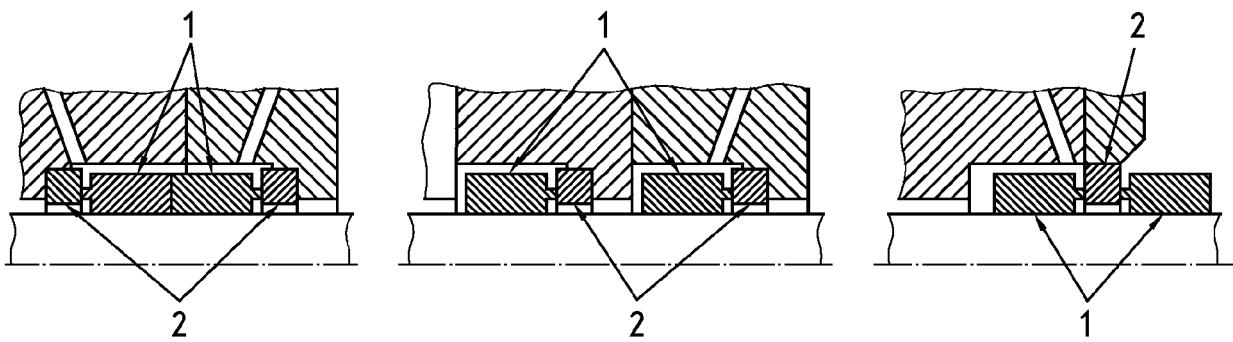

The same arrangements are possible with a rotating ring (mating ring)

Key

- 1 Spring-loaded ring
- 2 Seat ring

Figure E.3 — Examples of multiple mechanical seals

E.5 Quench arrangement (Q) for soft packing, single or multiple mechanical seal³⁾

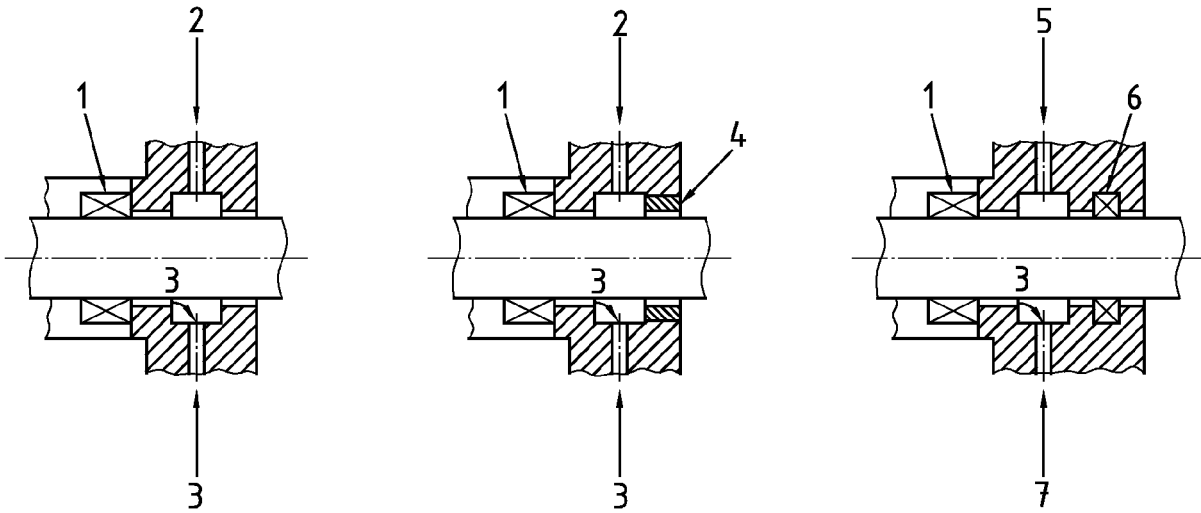

Q1 Main seal without throttle bush Q2 Main seal with throttle bush
or auxiliary seal

Q3 Main seal with auxiliary seal or
packing

Key

- | | | | |
|---|-----------------|---|--------------------|
| 1 | Main seal | 5 | Quench mandatory |
| 2 | Quench optional | 6 | Auxiliary seal |
| 3 | Leakage | 7 | Leakage and quench |
| 4 | Throttle bush | | |

Figure E.4 — Examples of quenching arrangements

Annex F (informative)

Piping arrangements for seals

F.1 General

Tables F.1 and F.2 show the principles of piping arrangements for seals and not details of their construction.

F.2 Seal types according to basic piping

Table F.1 — Seal types

Designation code	Equivalent from ISO 13709	Basic arrangement		Applied to			
		Figure	Description	Soft packing P	Single mechanical seal S	Multiple mechanical seal D	Quench Q
00	Plan 02		No piping, no circulation	X	X		
01	Plan 01		No piping, internal circulation	X	X		
02	Plan 11		Circulated fluid from pump outlet to seal cavity (with internal return)	X	X		
03	Plan 14		Circulation fluid from pump outlet to seal cavity and return to pump inlet ^a	X	X		

Table F1 (continued)

Designation code	Equivalent from ISO 13709	Basic arrangement		Applied to			
		Figure	Description	Soft packing P	Single mechanical seal S	Multiple mechanical seal D	Quench Q
04	Plan 31		Circulation fluid via cyclone (with internal return); dirty line to pump inlet	X	X		
05	---		Circulation fluid via cyclone; dirty line to drain	X	X		
06	Plan 23		Circulation fluid by pumping device from seal cavity via heat exchanger back to seal cavity		X		
07	Plan 13		Internal circulation fluid to seal and return to pump inlet	X	X		

Table F.1 (continued)

Designation code	Equivalent from ISO 13709	Basic arrangement		Applied to			
		Figure	Description	Soft packing P	Single mechanical seal S	Multiple mechanical seal D	Quench Q
08	a) Plan 32 b) Plan 62		Fluid from an external source: a) to seal cavity with flow into pump b) to quench	X	X	X	X
09	Plan 54 (Seal cavity)		External fluid (for example, injection, buffer fluid) to seal cavity/quench, outlet to an external system	X	X	X	X
10	Plan 52 (Quench)		Barrier or quenching fluid supplied by head tank, circulation by thermosiphon or pumping device			X	X
11	Plan 53 (Seal cavity)		Barrier or quenching fluid supplied by pressurized tank, circulation by thermosiphon or pumping device			X	X
12	—		Barrier fluid supplied by pressurized tank, circulation by thermosiphon or pumping device; tank pressurized by pump outlet via pressurizing device (e.g. tank with diaphragm)			X	

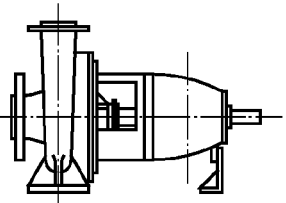
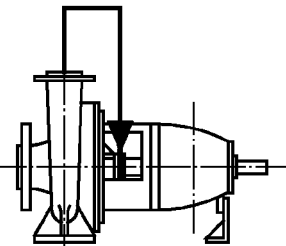
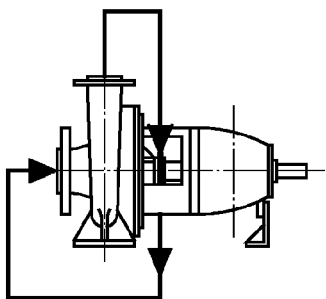
Table F.1 (continued)

Designation code	Equivalent from ISO 13709	Basic arrangement		Applied to			
		Figure	Description	Soft packing P	Single mechanical seal S	Multiple mechanical seal D	Quench Q
13	---		Barrier or quenching fluid supplied from head tank	X			X
<p>^a A cyclone is only suitable, if</p> <ul style="list-style-type: none"> — the differential pressure of the cyclone is W2 bar, and — the relation of the density of solids to the density of the pumped liquid is W1,5. 							

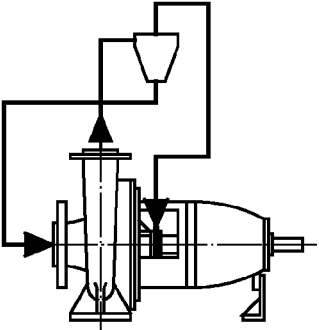
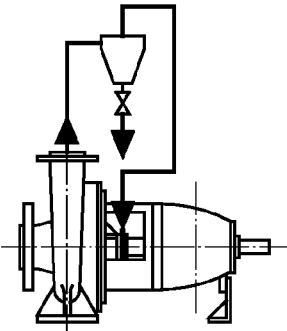
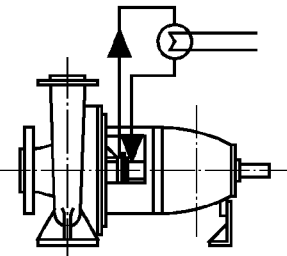
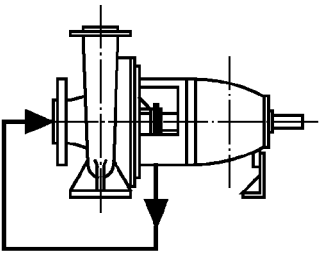
F.3 Designation of piping arrangements for seals

The designation consists of a capital letter, representing the seal arrangement (P, S, D, Q) and a number (1, 2, 3; see annex E), representing the basic piping arrangement (01, 02, 03 etc.; see Table F.1) (which does not represent the location of the seal cavity) linked by a full stop.

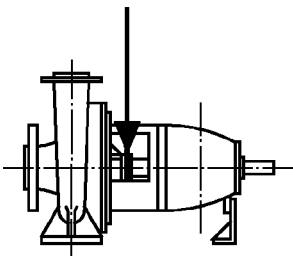
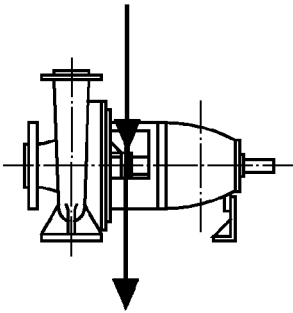
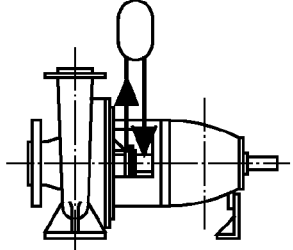
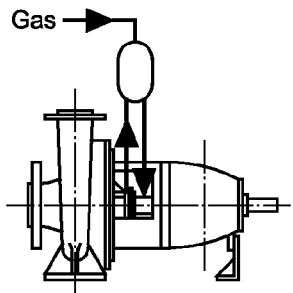
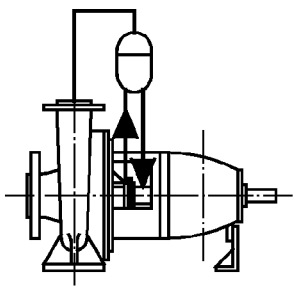
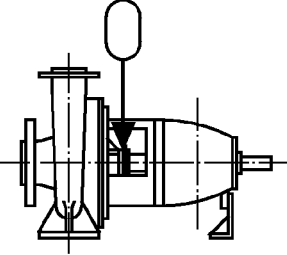
Where the auxiliaries are connected, they are represented by their code numbers (see Table F.2). The sequence corresponds to their arrangement in the direction of flow.

When the flow starts and ends at the seal cavity (closed circuit), the enumeration of the code has the same sequence.

The position of the seal cavity in a piping arrangement, which starts before and is continued after the seal cavity, shall be denoted by a dash.

Combination of different pipe arrangements with different seal arrangements is possible. In such cases the designation sequence of piping arrangements corresponds to those of the seal arrangement starting at the pump side (see annex G, examples 5 and 8).

When an auxiliary component is part of or within the pump or other components, its code shall be enclosed by brackets.

F.4 Explanation for auxiliaries for seal piping

See Table F.2.

NOTE Symbols are under study within Technical Committees ISO/TC 10, *Technical drawings*, and ISO/TC 145, *Graphical symbols*. Relevant references are indicated in the "Taken from" column.

Table F.2 — Auxiliaries for seal piping

Designation code	Symbol	Designation	Taken from
10	Valves		
11		Shut-off valve	ISO 3511-1:1977, 3.4
12		Hand control valve for pressure or flow control	
13		Automatic control valve	ISO 3511-1:1977, 3.4 and 3.5.1
14		Automatic pressure control valve	
15		Solenoid valve	ISO 3511-1:1977, 3.4 ISO 3511-2:1984, 6.4.4
16		Check valve	
17		Relief valve	
20	Orifices		
21		Non-adjustable orifice	
22		Adjustable orifice for flow and pressure control	

Table F.2 (continued)



Designation code	Symbol	Designation	Taken from
30	Filter and strainer		
31		Strainer	
32		Filter	ISO 3511-3:1984, 3.5.1.4
40	Indicators		
41		Pressure indicator	
42		Temperature indicator	ISO 1219-1:1991, 10.1.2
43		Flow indicator	ISO 3511-1:1977, 6.1.1
44		Level indicator	ISO 3511-1:1977, 6.1.6
50	Switches		
51		Pressure switch	
52		Level switch	
53		Flow switch	

Table F.2 (continued)

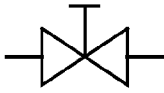
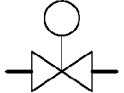
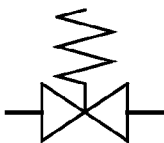
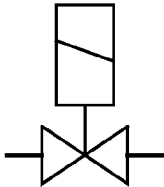
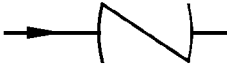
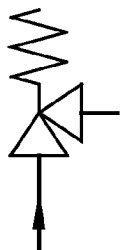
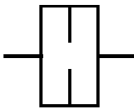
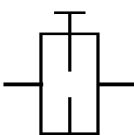



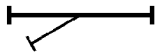
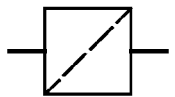
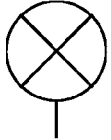
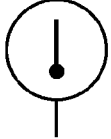
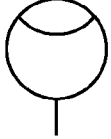

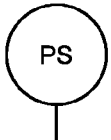
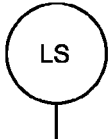
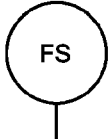
Designation code	Symbol	Designation	Taken from
54		Temperature switch	
60	Apparatus		
61		Cyclone	
62		Cyclone with hand regulating valve in dirty line	
63		Heat exchanger	ISO 7000:1989, 0111
64		Tank	ISO 3511-3:1984, 3.5.1.6
65		Tank with diaphragm	
66		Tank with pressure intensifier	
67		Tank with liquid injection of refilling device	
68		Circulation pump	ISO 7000:1989, 0134
69		Electric motor	

Table F.2 (continued)

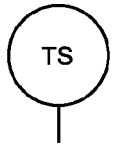
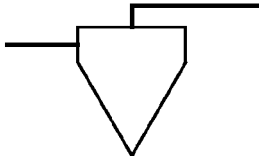
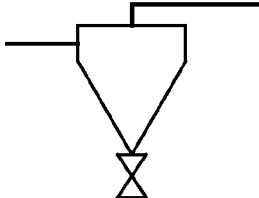
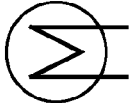
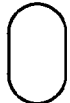
Designation code	Symbol	Designation	Taken from
70		Cooling coil	
71		Electric tank heater	

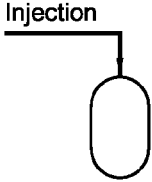
Annex G
(informative)

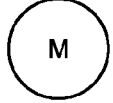
Designation examples using references from annexes E and F

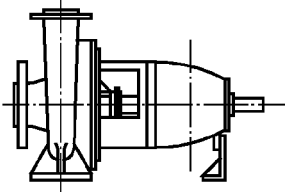
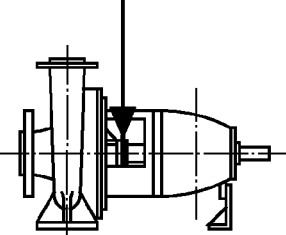
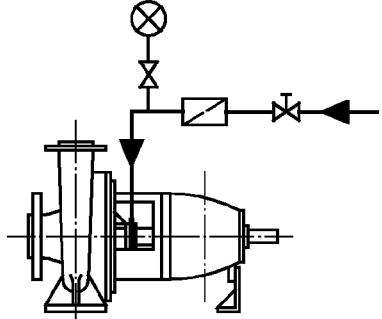
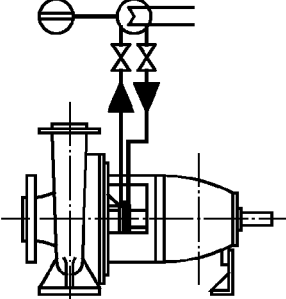
Example No.	Figure	Designation	Explanation
1		P1.01	Soft packing – P1 Basic arrangement 01
2		S1.08	Single mechanical seal – S1 Basic arrangement 08
3		S1.08-12.32.11.41	Single mechanical seal – S1 Basic arrangement 08 Hand control valve – 12 Filter – 32 Shut-off valve – 11 Pressure indicator – 41
4		D1.10-11.64(63.44)11	Double mechanical seal – D1 Basic arrangement 10 Isolation valve (optional) – 11 Tank – 64 Heat exchanger (internal) – 63 Level indicator (internal) – 44 Shut-off valve (optional) – 11

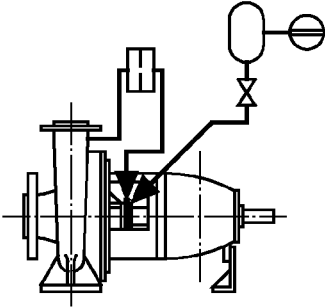
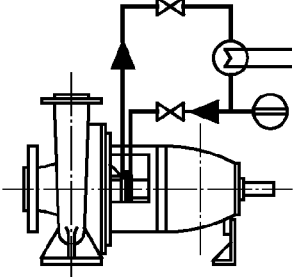
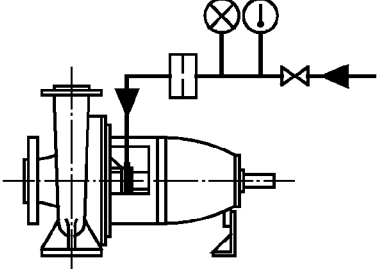
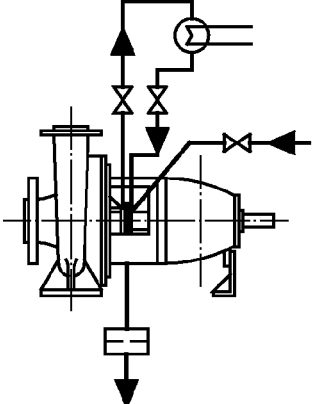
Example No.	Figure	Designation	Explanation
5		S1.02-21Q3.13-64(44)11	<p>Single mechanical seal – S1 Basic arrangement 02 Orifice – 21 Quench – Q3 Basic arrangement 13 Tank – 64 Level indicator (internal) – 44 Shut-off valve – 11</p>
6		S1.06-11.63.41.11	<p>Single mechanical seal – S1 Basic arrangement 06 Shut-off valve (optional) – 11 Heat exchanger – 63 Pressure indicator – 41 Shut-off valve (optional) – 11</p>
7		S1.08-11.42.41.21	<p>Single mechanical seal – S1 Basic arrangement 08 Shut-off valve – 11 Temperature indicator – 42 Pressure indicator – 41 Orifice – 21</p>
8		S1.06-11.63.11Q3.09-11-21	<p>Single mechanical seal – S1 Basic arrangement 06 Shut-off valve (optional) – 11 Cooler – 63 Shut-off valve – 11 Quench – Q3 Basic arrangement 09 Shut-off valve (optional) – 11 Orifice – 21</p>

Annex H (informative)

Checklist

The following list indicates by paragraph number where a decision may be required by the purchaser, or agreement is required between the purchaser and the manufacturer/supplier.

a) Design

- 4.1.2 Characteristic curves of the smallest and largest impeller diameter
 - Requirement for possibility of increasing head by 5 %
 - Position of duty point relative to best efficiency point
- 4.1.3 NPSHR basis
- 4.3.1 Flexible shaft
- 4.4.2 Corrosion allowance
- 4.4.4.3 Heating jacket design pressure and temperature
- 4.5.3 Vent pressure-gauge and drain
- 4.5.5 Type of auxiliary pipe connections
- 4.6 External forces and moments on flanges
- 4.8.1 Impeller construction
- 4.11.3 Condition for shaft deflection calculation
- 4.11.8 Arrangement of shaft sleeve for certain mechanical seals
- 4.12.5 Temperature monitoring at bearing locations
- 4.13.3.1 Mechanical seal arrangement
- 4.13.3.3 Auxiliary seal to retain leakage
 - Holes for mechanical seal services
 - Outlet connections for lantern ring
- 4.13.6 Auxiliary piping
- 4.14.1 Additional information on the nameplate
- 4.15 Coupling: information if the pump is delivered without driver
- 4.16.1 Baseplate: baseplate dimensions for ISO 2858 pumps if other than ISO 3661
 - Baseplate: materials and grouting

4.16.4 Baseplate: provision for collecting and draining leakage

4.16.5.2 Purchaser supplied driver: certified installation dimensions, drilling of driver fixing holes

b) Materials

5.1 Materials for hazardous liquids

5.2 Material composition, quality tests and certificates

c) Shop inspection and tests

6.1.1 Tests required

6.2.2 Inspection

6.3.1 Extent of participation

6.3.2 Material tests

6.3.4.1 Conversion methods for test liquids other than clean cold water and for different operating conditions

6.3.4.2 Grade of performance testing

6.3.4.3 NPSH test

6.3.4.4 Additional checks

6.3.4.5 Noise test

d) Preparation for dispatch

7.1 Shaft seals

e) Annexes

B.2 Agree external forces and moments for pump types not covered

B.4.1 Additional possibilities

B.5 Type of baseplate

D.1 special style or form of documentation

Bibliography

- [1] ISO 1219-1:1991, *Fluid power systems and components — Graphic symbols and circuit diagrams — Part 1: Graphic symbols*
- [2] ISO 1940-1, *Mechanical vibration — Balance quality requirements of rigid rotors — Part 1: Determination of permissible residual unbalance*
- [3] ISO 2041, *Vibration and shock — Vocabulary*
- [4] ISO 3511-1:1977, *Process measurement control functions and instrumentation — Symbolic representation — Part 1: Basic requirements*
- [5] ISO 3511-2:1984, *Process measurement control functions and instrumentation — Symbolic representation — Part 2: Extension of basic requirements*
- [6] ISO 3511-3:1984, *Process measurement control functions and instrumentation — Symbolic representation — Part 3: Detailed symbols for instrument interconnection diagrams*
- [7] ISO 7000:1989, *Graphical symbols for use on equipment — Index and synopsis*
- [8] ISO 9905, *Technical specifications for centrifugal pumps — Class I*
- [9] ISO 9908, *Technical specifications for centrifugal pumps — Class III*
- [10] ISO 10816-1, *Mechanical vibration — Evaluation of machine vibration by measurements on non-rotating parts — Part 1: General guidelines*
- [11] ISO 10816-3, *Mechanical vibration — Evaluation of machine vibration by measurements on non-rotating parts. — Part 3: Industrial machines with nominal power above 15 kW and nominal speeds between 120 r/min and 15 000 r/min when measured in situ*
- [12] CEN-CR 13931:2000, *Rotodynamic pumps — Forces and moments on flanges, centrifugal, mixed flow and axial flow pumps — Horizontal shaft and vertical shafts*